

M641

Programmable RTD Simulator

Operation manual

MEATEST

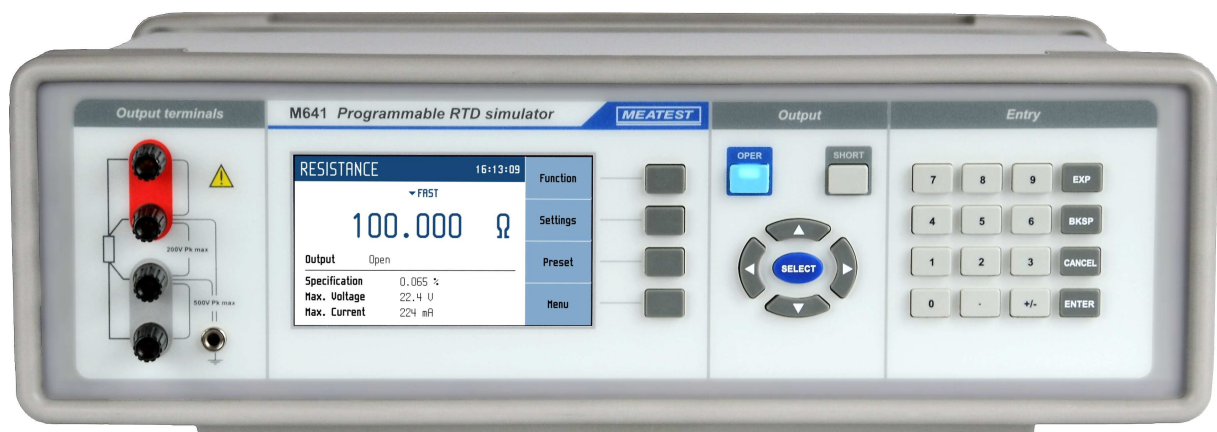

Content

FIGURES	4
TABLES	4
1. BASIC INFORMATION	5
2. PREPARATION FOR USE	5
2.1. INSPECTING PACKAGE CONTENTS, SELECTING THE INSTALLATION LOCATION	5
2.2. POWER ON.....	5
2.3. WARM-UP TIME.....	6
2.4. SAFETY PRECAUTIONS	6
3. DESCRIPTION	7
3.1. FRONT PANEL.....	7
3.2. REAR PANEL.....	9
4. OPERATION	10
4.1. CONNECTION AND DISCONNECTION OF OUTPUT TERMINALS	10
4.2. WIRES CONNECTION.....	10
4.3. SETTING THE FUNCTION.....	10
4.4. SETTING THE VALUE OF OUTPUT SIGNAL.....	17
4.5. PARAMETER SETTINGS (SETTINGS MENU)	18
4.6. PRESET MENU.....	18
4.7. MAIN MENU.....	19
4.8. CALIBRATION MODE.....	21
5. PERFORMANCE VERIFICATION TEST	24
6. REMOTE CONTROL	25
6.1. RS232 INTERFACE	25
6.2. GPIB INTERFACE (OPTION)	26
6.3. LAN INTERFACE (OPTION)	27
6.4. USB INTERFACE (OPTION).....	28
6.5. COMMAND SYNTAX.....	29
6.6. SCPI COMMAND TREE.....	30
6.7. STANDARD STATUS DATA STRUCTURES	32
6.8. SCPI STANDARD COMMANDS	34
6.9. SCPI COMMANDS	38
6.10. SCPI ERROR CODES	63
6.11. COMPATIBLE COMMANDS	64
6.12. DEMO PROGRAM	66
7. MAINTENANCE	67
7.1. FUSE REPLACING	67
7.2. EXTERNAL SURFACE CLEANING.....	67
8. MODULE 19” (VERSION M641-VXX1X)	67
9. TECHNICAL DATA	68
10. ORDERING INFORMATION – OPTIONS	70

Figures

Figure 1 Starting Screen.....	6
Figure 2 Front panel.....	7
Figure 3 Display.....	7
Figure 4 Rear panel.....	9
Figure 5 Resistance screen.....	10
Figure 6 Platinum screen.....	11
Figure 7 Nickel screen.....	11
Figure 8 User function screen.....	12
Figure 9 User function list.....	12
Figure 10 New user function.....	13
Figure 11 User function point editing.....	13
Figure 12 User function edit.....	14
Figure 13 Timing screen.....	14
Figure 14 Time sequence list.....	15
Figure 15 New sequence.....	15
Figure 16 Timing sequence point editing.....	16
Figure 17 Timing sequence edit.....	16
Figure 18 Numeric value entry.....	17
Figure 19 Settings menu.....	18
Figure 20 Preset menu.....	18
Figure 21 Main menu.....	19
Figure 22 Password entry.....	21
Figure 23 Calibration point screen.....	23
Figure 24 RS232 9 pin D-SUB MALE connector.....	25
Figure 25 IEEE488 connector.....	26
Figure 26 LAN connection 1.....	27
Figure 27 LAN connection 2.....	27
Figure 28 USB connector.....	28
Figure 29 Status register overview.....	32
Figure 30 Module 19" rack, front panel.....	67

Tables

Table 1 M641 Calibration points.....	22
Table 2 Verification - allowed deviations.....	24
Table 3 RS232 cable connection.....	26
Table 4 OUTPut command structure.....	41
Table 5 Keyboard codes.....	60
Table 6 SCPI error codes.....	63
Table 7 M641 Resistance accuracy.....	69
Table 8 M641 Pt simulation accuracy.....	69
Table 9 M641 Ni simulation accuracy.....	69
Table 10 M641 Frequency response.....	69

1. Basic information

Programmable RTD Simulator M641 is suitable for automated simulation of different resistance sensors (temperature, pressure, position, force ...). Internal design eliminates “zero resistance effect” which is typical for most resistance decades.

Resistance value is created via appropriate combination of physical resistors. RTD simulator is equipped with built-in function of direct simulation of most frequent temperature Pt and Ni sensors. Low thermal voltage relays and stable resistors are used as main parts of the RTD Simulator. Actual set values are displayed on high resolution TFT display. M641 is sophisticated instrument with its own re-calibration procedure. The procedure enables to correct any deviation in resistance without any mechanical adjustment.

Instrument is especially suitable for automatic testing procedures. RS232 line (optionally IEEE488, USB and Ethernet bus) is used for connecting RTD simulator to the computer.

2. Preparation for use

2.1. *Inspecting package contents, selecting the installation location*

Basic package includes the following items:

- RTD Simulator M641
- RS232 cable
- CD with demo program
- User's manual
- Test report

The instrument must be powered by 230/115 V – 50/60 Hz mains. Before powering on the instruments, place it on a level surface. If the instrument was stored out of range of reference temperatures, let it stabilize for one hour.

2.2. *Power on*

- Before connecting the instrument to the mains, check the position of the mains voltage selector located at the rear panel.
- Plug one end of the power cord into the connector located at the rear panel and connect the other end of the power cord into a wall outlet.

- Switch on the mains switch located at the rear panel. Display is lit.

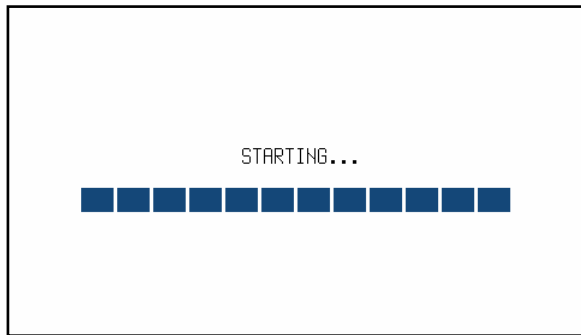

Figure 1 Starting Screen

- The instrument performs internal hardware checks for app. 5 seconds.
- After the tests conclude, the instrument is set to “Startup” preset. This preset is adjustable however, the instrument will always start with OPEN terminals.

2.3. Warm-up time

The instrument works after it is switched on and the initial checks complete. Specified parameters are only guaranteed after the instrument warms up for 10 minutes.

2.4. Safety precautions

The instrument has been designed according to EN 61010-1:2011. Safety is ensured by the design and by the use of specific component types.

The manufacturer is not liable for the damage caused by modification of the construction or replacement of parts with non-original ones.

Safety symbols used on the equipment



Warning, reference to the documentation

3. Description

3.1. Front panel

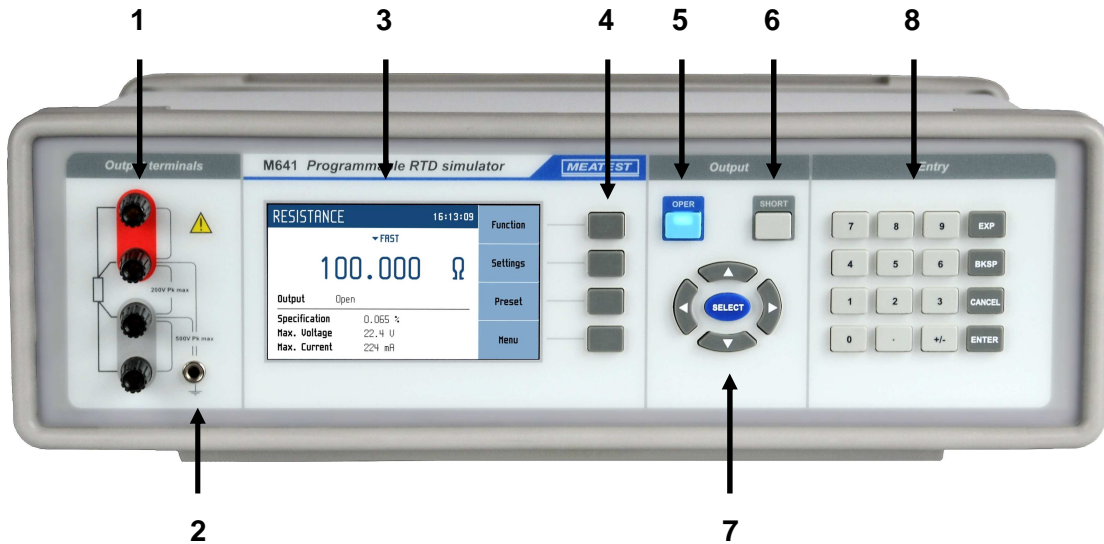

Figure 2 Front panel

On the front panel there are located all main control keys, display and output terminals.

1 Output terminals

Four wire output terminals. Measuring (evaluation) circuit can be connected by 2, 3 or 4 wires. Both sides (red and grey) are floating up to 500Vpk against the case (PE).

2 Ground terminal

Central ground terminal (protective earth) connected to the metal case of the instrument. It is recommended to connect it to the “grey” output terminals if connected meter is not grounded.

3 Display

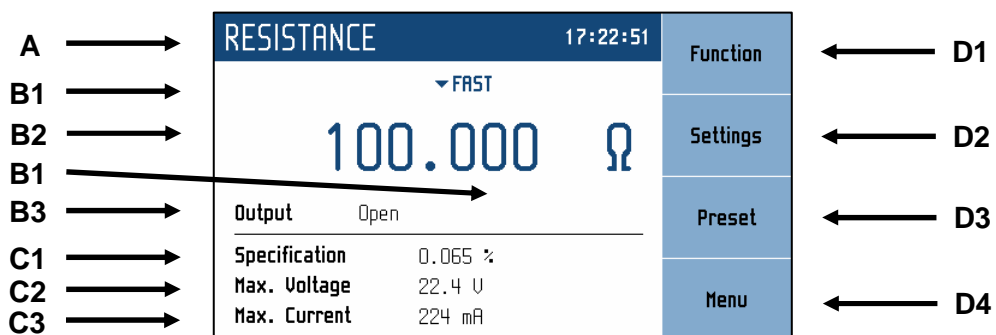

Figure 3 Display

The display is divided into four sections:

A. *Information line*

- Selected function (RESISTANCE, PLATINUM, ...)
- Time

B. *Main area*

This section displays the set-up values of generated signals and the data related to the simulator status. The section includes the following types of data:

1. *Auxiliary parameters*

This section displays auxiliary parameters of actually selected function:

- Temperature standard (PT385, PT3916, ...)
- Switching mode (FAST, VIA OPEN, ...)
- R0 resistance

2. *Main value*

There is displayed main value of selected function with the unit. There is displayed also actual position of cursor ▼▲ if the parameter is in edit mode. Position of cursor can be changed using keys ◀, ▶ and parameter can be changed using keys ▲, ▼.

3. *Output state*

There is displayed resistance value connected to the output terminals.

C. *Specification*

This section displays specification and limits relating to the main value:

1. *Specification*

This section displays specification of the main value.

2. *Maximum voltage*

This section displays maximum allowed voltage for the main value.

3. *Maximum current*

This section displays maximum allowed current for the main value.

D. *Softkey labels*

The functions of these keys change during operation (depends on selected function and actual display mode).

4 *Softkeys*

There are four keys next to the display with variable function. The functions of these keys change during operation (depends on selected function and actual display mode). These four softkeys appear in main function window:

Function – Function selection. See chapter 4.3

Settings – Function-specific parameter settings. See chapter 4.5

Preset – One click setup of all function parameters. See chapter 4.6

Menu – General settings and parameters of all functions. See chapter 4.7

5 OPER (Operate key)

OPER key connects / disconnects selected value to the output terminals. Connected output terminals are indicated by the lit LED in the key.

6 SHORT (Short key)

Active SHORT key (LED in the key is ON) replaces the main value with the short circuit. Also the short circuit must be connected to the output terminals by the OPER key.

7 Cursor keys

Using these keys, the cursor can be controlled within allowed limits on the display. The keyboard includes two buttons (◀, ▶) which allow the cursor to be moved to the left or right. When a list is displayed, (◀, ▶) buttons skip through pages. Buttons (▲, ▼) allow the user to increase or decrease the number at the cursor position or move across items in a list.

The central SELECT key is used to select value you want to change (like TAB key).

8 Numeric keyboard

The keyboard allows the entry of numeric values on the display. ENTER button is used to confirm the selection. CANCEL button can be used to cancel the entry.

Colors on display

Common rules are used for applied color of labels and values.

- **Red color** - displayed value is measured by the instrument. This color isn't used in all versions.
- **Blue color** - parameters or values, which can be set-up or modified directly from front panel keyboard or via Main menu.
- **Black color** - fix values, labels, notes, parameters which cannot be modified and for other fix text with general information purpose.

Meaning of softkeys is shown on the right side of display. If there is no description next to the softkey, the softkey is not active in selected function.

3.2. Rear panel

There are located power cord socket, power line fuse, power line voltage selector 115/230V, interface connectors RS232 and optionally LAN, USB and IEEE488 on the rear panel.



Figure 4 Rear panel

4. Operation

4.1. Connection and disconnection of output terminals

Set value is connected (disconnected) to the output terminals after pressing OPER key. Connected output terminals are indicated by the lit LED in the key.

Disconnected output terminals can be used for “Open terminals” simulation. “Short circuit” is simulated after pressing SHORT key. Active SHORT key (LED in the key is ON) replaces the main value with the short circuit. Also the short circuit must be connected to the output terminals by the OPER key.

4.2. Wires connection

Output resistance is available on R output terminals. Available is 2, 3 and 4-wire connection. Both sides (red and grey) are floating up to 500Vpk against the case (PE).

Ground terminal is connected to the metal case and to the protective earth (PE).

4.3. Setting the function

Function can be changed after pressing „Function“ softkey. New function is selected using cursor keys ▲, ▼ or display softkeys. Selection must be confirmed by pressing SELECT key or „OK“ softkey.

Device supports following functions:

Resistance

Offers direct setting of exact resistance value.

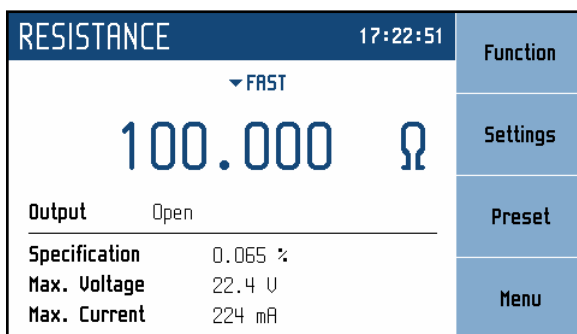

Figure 5 Resistance screen

Editable parameters:

Resistance value: 10 Ω ... 300 kΩ

Switching mode: FAST, SMOOTH, VIA OPEN, VIA SHORT

Platinum

Offers direct setting of temperature of simulated platinum thermometer.

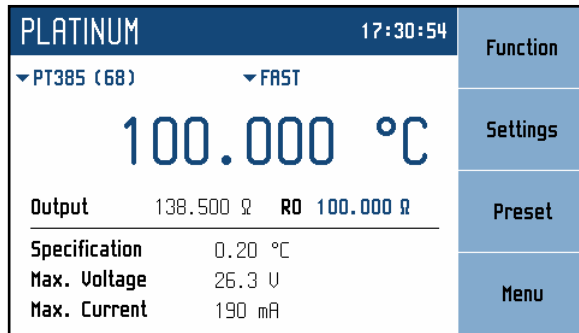

Figure 6 Platinum screen

Editable parameters:

Temperature: -200 °C ... +850 °C (-328 °F ... 1562 °F)
 R0 value: 100 Ω ... 1 kΩ
 Temperature standard: PT385 (68), PT385 (90), PT3916, PT3926, PT User
 Switching mode: FAST, SMOOTH, VIA OPEN, VIA SHORT

Nickel

Offers direct setting of temperature of simulated nickel thermometer.

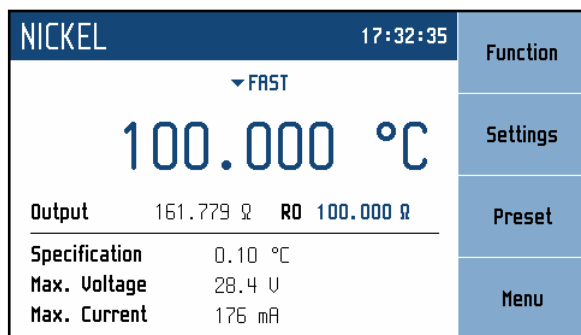

Figure 7 Nickel screen

Editable parameters:

Temperature: -60 °C ... +300 °C (-76 °F ... 572 °F)
 R0 value: 100 Ω ... 1 kΩ
 Switching mode: FAST, SMOOTH, VIA OPEN, VIA SHORT

User function

Offers simulation of conversion curve defined by a table. User can define more conversion curves. Values between defined points are linearly interpolated.

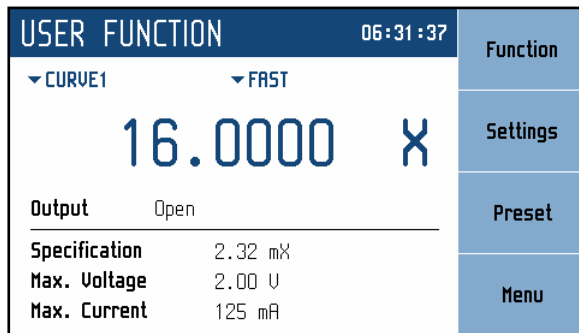

Figure 8 User function screen

Editable parameters:

Main value: according to the function
 User function: curves defined by the user
 Switching mode: FAST, SMOOTH, VIA OPEN, VIA SHORT

Function is defined by table of user values and corresponding resistance values. This table is called „Curve“ and is editable. Maximum number of tables is 64 with each table having up to 100 values. Tables can be defined via remote control as well. Manual table setup can be done in *Menu* → *Device* → *User function curve*:

Figure 9 User function list

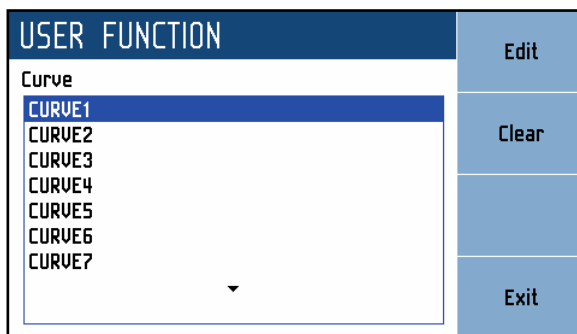

Menu shows a list of all previously defined tables (curves). Curve names can be customized. Softkeys on the right hand side of the panel have these functions:

Edit – edit selected curve. Table can be selected using cursor keys where ◀, ▶ skip through pages.

Clear – clear all curve data and set it to default (plain) state. Message prompt will appear before final curve clearance.

Exit – close the curve list and return previous menu.

Creating a new table

Pressing the *Edit* softkey upon plain curve opens this submenu:

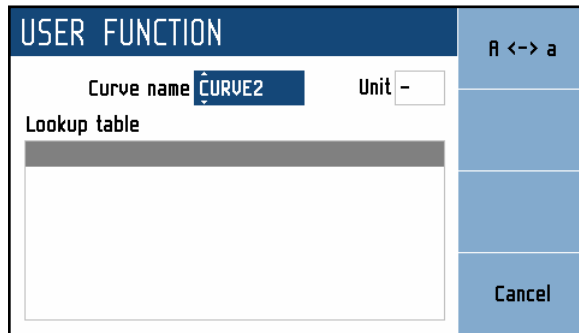

Figure 10 New user function

Curve name – table name is set using ▲, ▼ (character selection) and ◀, ▶ (position) cursor keys. Name may be 8 characters long at most. Softkey „A <-> a“ switches between uppercase and lowercase of selected character. Table name has to be set before proceeding to the next step using **SELECT** key.

Unit – user function unit abbreviation is set in the same way as table name only it can be just up to two characters long. Unit abbreviation has to be set before proceeding to the next step using the **SELECT** key.

Lookup table – a place where you define user function using values in Ω . Table must contain at least two “user function value \rightarrow Ω value” points so that a slope of the function can be calculated. Range in user function mode is given by actual resistance range of the simulator. Browsing through the table is done by ▲, ▼ cursor keys. Editing is done using these contextual softkeys:

Add – create a new point.

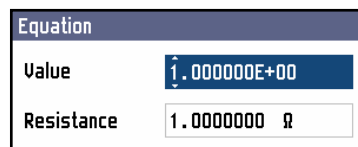

Figure 11 User function point editing

Value – user function value in user units. Press the **SELECT** key to proceed.

Resistance – corresponding Ω value. Range is given by the actual resistance range of the simulator.

Edit – show the “Equation” panel for selected point to allow editing.

Delete – delete selected point.

Cancel – deactivate the Lookup Table and allow for curve saving.

Save – closes the table and saves current settings.

Cancel – closes the table and does not save current settings.

Editing an existing table

Existing table can be edited in the same way as it can be created. Editable entries (Curve name, Unit, Lookup table points) are selected using the **SELECT** key.

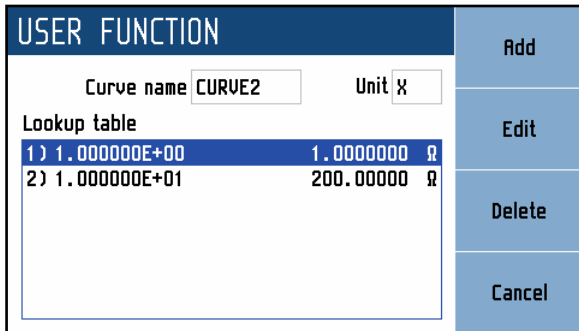

Figure 12 User function edit

Timing

Offers simulation of time-varying resistance defined by a table. User can define more time curves.

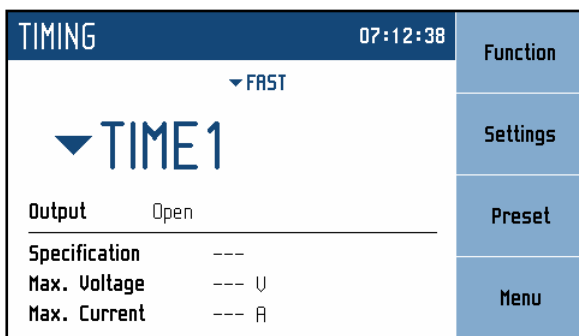

Figure 13 Timing screen

Editable parameters:

- Timing table: table defined by the user
- Switching mode: FAST, SMOOTH, VIA OPEN, VIA SHORT

Sequence is defined by table of time intervals and corresponding resistance values, all of which can be edited. Maximum number of tables is 64 with each table having up to 100 time intervals. Sequence is started by pressing OPER button or sending OUTF ON command via remote control. Final state of every sequence is OPEN. Manual table setup can be done in *Menu* → *Device* → *Timings*:

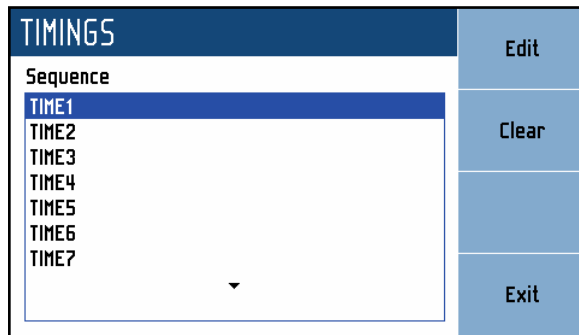

Figure 14 Time sequence list

Menu shows a list of all sequences. Softkeys on the right hand side of the panel have these functions:

Edit – edit selected sequence. Sequence can be selected using cursor keys where ◀, ▶ skip through pages.

Clear – clear all sequence data and set it to default (plain) state. Message prompt will appear before final clearance of the sequence.

Exit – close the sequence list and return previous menu.

Creating a new table

Pressing the *Edit* softkey upon plain sequence opens this submenu:

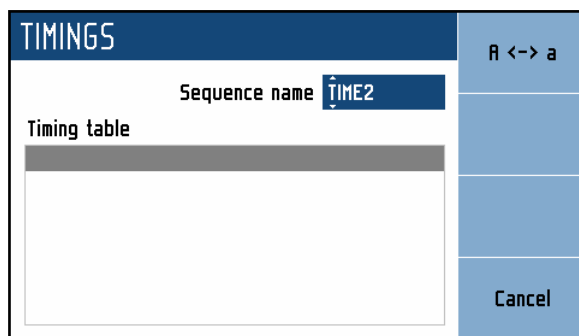
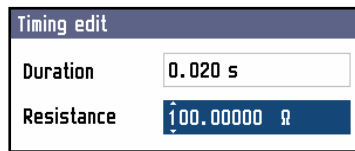

Figure 15 New sequence

Preset name – table name is set using ▲, ▼ (character selection) and ◀, ▶ (position) cursor keys. Name may be 8 characters long at most. Softkey „A <-> a“ switches between uppercase and lowercase of selected character. Table name has to be set before proceeding to the next step using **SELECT** key.

Timing table – a list of values in Ω and their durations in seconds. Browsing through the table is done by \blacktriangle , \blacktriangledown cursor keys. Editing is done using these softkeys:

Add – create a new point.



The image shows a 'Timing edit' dialog box with two input fields. The 'Duration' field contains '0.020 s' and the 'Resistance' field contains '100.00000 Ω '. The Resistance field has a small upward arrow on the left side.

Figure 16 Timing sequence point editing

Duration – duration of selected resistance (from 2 ms to 60 s). Press the **SELECT** key to proceed.

Resistance – corresponding Ω value. Range is given by the actual resistance range of the simulator.

Edit – show the “Timing edit” panel for selected point to allow editing.

Delete – delete selected point.

Cancel – deactivate the Lookup Table and allow for curve saving.

Save – closes the table and saves current settings.

Cancel – closes the table and does not save current settings.

Editing an existing table

Existing table can be edited in the same way as it can be created. Editable entries (Preset name, Timing table points) are selected using the **SELECT** key.

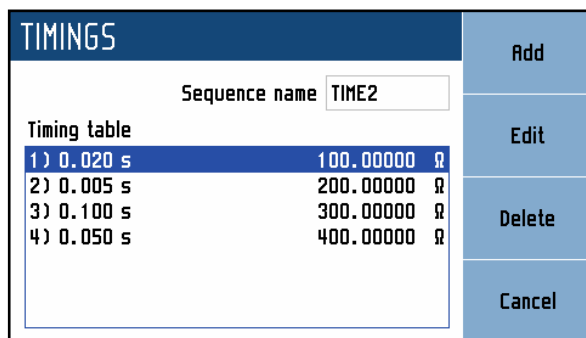

The image shows a 'TIMINGS' dialog box. At the top, there is a 'Sequence name' field containing 'TIME2'. Below this is a 'Timing table' with four entries:

Point	Duration	Resistance
1)	0.020 s	100.00000 Ω
2)	0.005 s	200.00000 Ω
3)	0.100 s	300.00000 Ω
4)	0.050 s	400.00000 Ω

On the right side of the dialog box, there are four buttons: 'Add', 'Edit', 'Delete', and 'Cancel'. The 'Edit' button is highlighted, indicating that the first point in the table is selected for editing.

Figure 17 Timing sequence edit

4.4. Setting the value of output signal

Edit mode

Parameters of output signal can be changed in Edit mode. Only parameters displayed in blue color can be changed. Display can be switched to edit mode in different ways:

- Pressing numeric button
- Pressing **SELECT** key
- Pressing cursor button

In edit mode is edited value highlighted by blue background. Pressing the **SELECT** key you can change among editable (blue) parameters. Edit mode is finished by pressing CANCEL key.

Entry of the value using numeric keyboard

- Use the numeric keyboard to set the desired value. After the first digit is entered, input box is displayed. In the upper row of the input box is the name of edited parameter. Using softkeys you can enter the new value in different units.

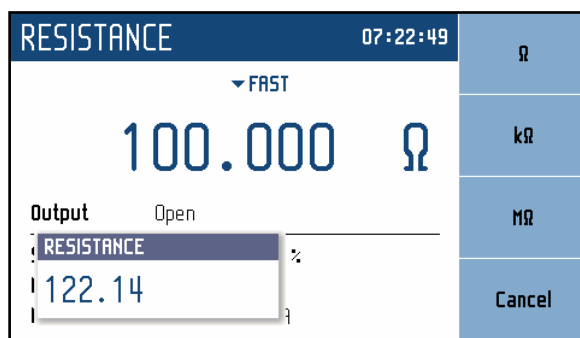

Figure 18 Numeric value entry

- Enter desired value.
- After the entry is complete press softkey with requested unit or press ENTER key. ENTER key inputs the value in basic units (Ω , $^{\circ}\text{C}$, ...).
- Instrument sets the new value.
- The value is copied to the appropriate field in the screen and the input box disappears.

Entry of the value using cursor keys

- Press \blacktriangleleft , \blacktriangleright , \blacktriangle or \blacktriangledown key. The display now includes cursor marks which points to the active digit.
- \blacktriangle , \blacktriangledown keys can be used to change the value. \blacktriangleleft , \blacktriangleright keys can be used to change the position of active digit.
- To get to the default screen, press CANCEL key.

Note:

- All parameters have limits (high and low). If the entered value is outside these limits warning message is displayed („Value too high (low)“) and new value is not accepted.

4.5. Parameter settings (settings menu)

Settings menu is displayed after pressing „Settings“ softkey in main function window. It won't appear in editing mode so when in editing mode you have to press “Cancel” first.

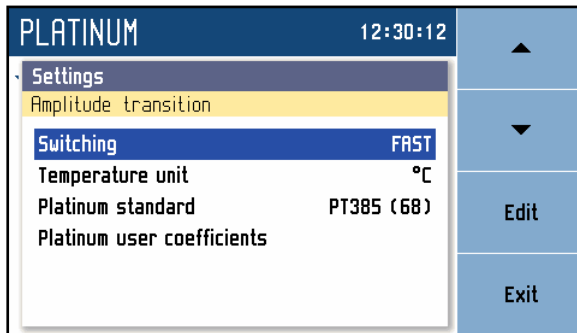

Figure 19 Settings menu

In settings menu you can edit all available auxiliary parameters of the current function. These settings are discarded on restart so if you'd like to save them for your next calibration session, use the “Preset” feature.

4.6. Preset menu

Preset menu is displayed after pressing „Preset“ softkey in main function window. It won't appear in editing mode so when in editing mode you have to press “Cancel” first.

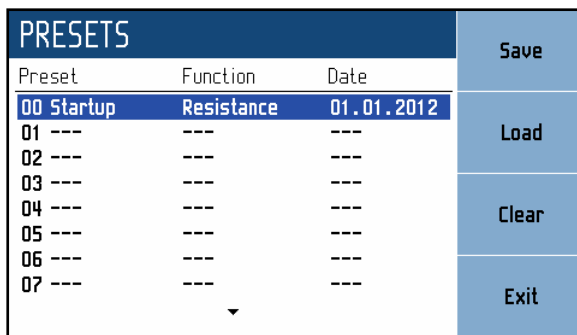

Figure 20 Preset menu

Presets contain all settings that normally disappear on restart. This includes function parameters for all functions (see previous chapter), selected function and the main value. Presets doesn't contain system, interface or calibration data as well as output state, short state, timing tables and user function tables. Up to a 100 presets can be stored including a special “Startup” preset which is loaded on every device startup. Preset can be selected using cursor keys where ◀, ▶ skip through pages.

Save – Save current device settings to selected preset. Preset name can be edited before final saving.

Load – Load selected preset and return to function window defined by the preset.

Clear – Set selected preset to default factory setup.

Exit – Return to main function window.

4.7. Main menu

Main menu is displayed after pressing „Menu“ softkey. In main menu you can set all the parameters available.

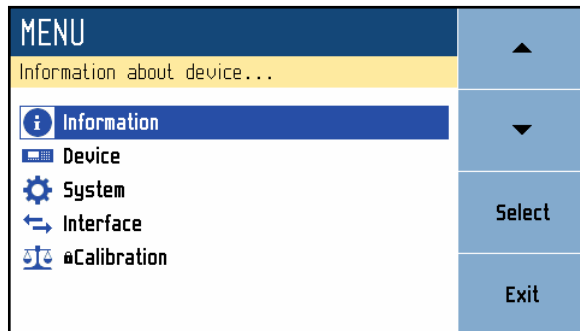

Figure 21 Main menu

Required menu item is highlighted using cursor keys ▲, ▼ or display softkeys. Highlighted menu is selected by pressing **SELECT** key or „Select“ softkey. Only editable items can be selected.

Information

This menu displays information about the device. Items can't be changed by the user.

Manufacturer

Model

Serial number

Software version

Hardware version

Device

This menu permits setting operational parameters of device.

Temperature unit

Temperature functions can be expressed in different units. Available units are °C (Celsius), °F (Fahrenheit) and K (Kelvin).

Switching

Item defines the way how resistance value is changed. Value R1 is changed to value R2 in the time interval T. Resistance connected to the output terminals can have different values during the time interval T.

FAST	Fastest possible switching method. T is typically 400us. Resistance during T is undefined. It can be higher or lower than R1 (R2).
SMOOTH	Method with smallest possible resistance change. T is typically 1ms. Resistance during T can't be higher than max (R1, R2) and can be lower than min (R1, R2).
VIA OPEN	2 steps switching method. R1 is switched to OPEN and than to R2. T is typically 1ms.

VIA SHORT 2 steps switching method. R1 is switched to SHORT and than to R2.
T is typically 1ms.
SHORT value is lower than min (R1, R2).

Platinum standard

Platinum thermometers can be simulated according to the different standards. Available standards are:

PT385 (68)	DIN, standard EN60751, temperature scale IPTS68 (A=3.90802e-3, B=-5.80195e-7, C=-4.2735e-12)
PT385 (90)	DIN, standard EN60751, temperature scale ITS90 (A=3.9083e-3, B=-5.775e-7, C=-4.18301e-12)
PT3916	Pt3916 temperature curve (A=3.9692e-3, B=-5.8495e-7, C=-4.2325e-12)
PT3926	Pt3926 temperature curve (A=3.9848e-3, B=-5.870e-7, C=-4.0e-12)
PT User	user defined temperature curve (A=3.9083e-3, B=-5.775e-7, C=-4.18301e-12) – values can be changed

Platinum user coefficients

This menu permits A, B and C coefficients definition of the PT User platinum standard (see above).

Timings

This menu permits definition of different time dependent resistance curves. Each curve is defined by the Timing table. Each row in the table contains information about resistance value and duration for which is this value applied. If the timing function is activated all rows are sequentially executed. User can define more timing tables with different names. Number of sequences is limited to 64.

User function curve

This menu permits definition of different conversion curves. Each curve is defined by the Lookup table. Each row in the table contains information about value of simulated function and appropriate resistance value. User can define more lookup tables with different names. Typical application is definition table for simulation of non-standard resistance thermometers. Number of conversion curves is limited to 64.

System

This menu permits setting system parameters of device.

Language

Language setting.

Backlight

Display backlight level setting.

Beeper volume

Beeper volume level setting.

Keyboard beep

Enables / Disables keyboard beep.

Time

Internal time setting.

Date

Internal date setting

Interface

This menu permits setting parameters of remote control interfaces.

Active bus

Active bus setting. Only active bus can be used for remote control.

RS232 Baudrate

RS232 communication baudrate setting. The same baudrate must be used in the controller.

GPIB Address

GPIB address setting. Each instrument connected to the GPIB bus must have a unique address.

LAN Settings

Ethernet parameters setting. Device use Telnet protocol. Default setting is:

DHCP	ON	
IP Address	192.168.001.100	only valid if DHCP is OFF
Subnet mask	255.255.255.000	only valid if DHCP is OFF
Default gateway	255.255.255.255	only valid if DHCP is OFF
Port number	23	
Host name	M641_SN620031	only valid if DHCP is ON

4.8. Calibration mode

In this mode resistance elements of the RTD simulator can be recalibrated. Access to the calibration mode is from the setup Menu.

Correct password must be entered before calibration. Without correct password the access to the calibration mode is refused. Default factory set calibration code is “2”. Return to standard mode is possible after pushing the key ESC.

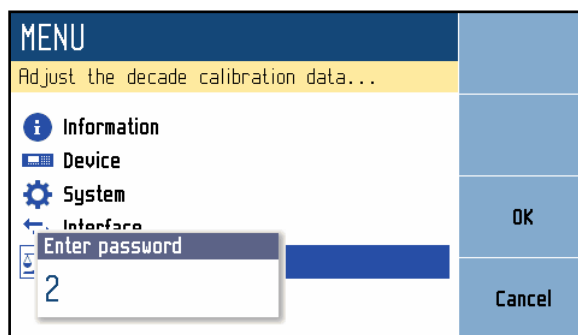

Figure 22 Password entry

Recalibration procedure consists of measuring of 24 basic resistance values and entering their actually measured data. Calibration point can be changes using display softkeys “Previous” and “Next”. Calibration value of selected resistance can be change using cursor keys ▲, ▼, ◀, ▶.

Following table describes nominal values of calibration points and requested recalibration accuracy:

Calibration points M641

Standard	Nominal value	Requested Accuracy
R1	20 Ω	1 m Ω
R2	38,8 Ω	1 m Ω
R3	75,6 Ω	2 m Ω
R4	148 Ω	3 m Ω
R5	287 Ω	6 m Ω
R6	570 Ω	15 m Ω
R7	1,13 k Ω	30 m Ω
R8	2,23 k Ω	100 m Ω
R9	4,4 Ω	250 m Ω
R10	8,7 k Ω	500 m Ω
R11	17 k Ω	1 Ω
R12	33,3 k Ω	5 Ω
R13	66 k Ω	10 Ω
R14	130 k Ω	20 Ω
R15	258 k Ω	40 Ω
R16	506 k Ω	80 Ω
R17	1 M Ω	200 Ω
R18	2 M Ω	400 Ω
R19	3,99 M Ω	1 k Ω
R20	7,8 M Ω	5 k Ω
R21	15 M Ω	50 k Ω
R22	30 M Ω	200 k Ω
R23	60 M Ω	500 k Ω
R24	120 M Ω	1 M Ω

Table 1 M641 Calibration points

Process of calibration consists of measuring partial resistances and writing their actual values into the RTD simulator:

- Set the first calibration point (resistance element). Use display softkeys “Previous” and “Next” to select the element.
- Measure resistance of the selected element. Use ohm-meter with appropriate accuracy in 4-wire connection mode.

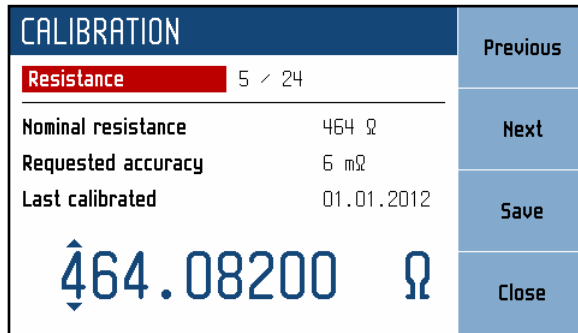

Figure 23 Calibration point screen

- Using cursor keys ▲, ▼, ◀, ▶ adjust resistance value in M641 according to the ohm meter.
- Confirm new calibration value by pressing “Save” softkey.
- Repeat above described procedure for all resistance elements.

Change password

In this menu you can change the password of the calibration mode. Default password is “2”.

5. Performance verification test

Parameter verification procedure is described in the chapter. Verification procedure is based on measuring resistance on the simulator output terminals with standard multimeter in recommended points.

Required equipment

- Ohm-meter nominal accuracy 0.001% in range 1 Ω to 1.2 M Ω (type Fluke 8508A or similar)

RTD simulator setting

Switch RTD simulator to the resistance function. Connect standard multimeter to the simulator output terminals. Use four-wire connection technique.

Procedure

Use following procedure to perform parameter verification test:

1. Switch both instruments on and let them for 1 hour stabilise in the laboratory with ambient temperature 23 ± 3 °C. Connect simulator terminals 4W to the standard ohm-meter (multimeter).
2. Case of the simulator should be grounded or connected to the Lo terminal of multimeter.
3. Check resistance value in points according to Table I.

Maximal absolute deviations M641

Nominal value	M641 max. deviation
19 Ω	25 m Ω
36 Ω	33 m Ω
70 Ω	50 m Ω
140 Ω	85 m Ω
250 Ω	50 m Ω
500 Ω	100 m Ω
1 k Ω	200 m Ω
2 k Ω	400 m Ω
4 k Ω	800 m Ω
8 k Ω	1.6 Ω
16 k Ω	8 Ω
30 k Ω	15 Ω
60 k Ω	60 Ω
120 k Ω	600 Ω
250 k Ω	1250 Ω

Table 2 Verification - allowed deviations

6. Remote control

RTD simulator can be controlled via RS232, GPIB, LAN and USB interface. The simulator can be only controlled by one of interfaces at a time. It is therefore necessary to select and set-up one of the interfaces using the system menu. All interfaces shares the same commands except following commands, which are intended only for use with RS232, LAN and USB interface:

SYSTem:LOCAl

This command places decade in the “LOCAL” mode.

SYSTem:REMote

This command places simulator in the “REMOTE” mode.

SYSTem:RWLock

This command places the simulator in the “REMOTE” mode and locks all keys (including LOCAL key) on front panel.

NOTE: If device is not in REMOTE mode all other commands are ignored by simulator (for RS232, LAN and USB interface). With the exception of Compatible commands which are processed each time. GPIB interface places device in the “REMOTE” mode automatically by opening the GPIB interface and therefore these commands are not intended for this interface.

6.1. RS232 Interface

The simulator can be controlled via standard RS232 interface.

Following equipment is required:

- M641 RTD simulator
- Personal Computer (or other controlling device) with RS232 port (USB-to-RS232 converter is also possible)
- 9-pin D-SUB, 3-wire direct (1:1) male/female RS232 cable

The RS232 interface must be selected from decade system menu to be in operation (*SETUP->Interface->Active bus*). There is only one RS232 setting accessible from the simulator system menu under *SETUP->Interface* path:

RS232 Baudrate 1200, 2400, 4800, 9600, 19200, 38400, 57600 or 115200

Other RS232 parameters are fixed to the following settings:

Number of data bits	8
Number of stop bits	1
Parity	None
Handshake (XON/XOFF)	Off

RS232 connection

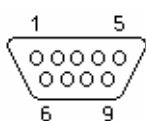

Pin	Label	I/O	Description
2	TXD	output	Transmitter
3	RXD	input	Receiver
5	GND	-	Ground

Figure 24 RS232 9 pin D-SUB MALE connector

Cable between decade and computer description (configuration 1:1)

Computer	D-Sub 1	D-Sub 2	M641
Receiver	2	2	Transmitter
Transmitter	3	3	Receiver
Ground	5	5	Ground

Table 3 RS232 cable connection

6.2. GPIB Interface (option)

The simulator can be controlled via GPIB (General Purpose Interface Bus) interface.

Following equipment is required:

- M641 simulator with LAN, USB, IEEE488 bus option
- Personal Computer (or other controlling device) with GPIB interface
- GPIB cable

The GPIB interface must be selected from simulator system menu to be in operation (*SETUP->Interface->Active bus*). There is only one GPIB setting accessible from the simulator system menu under *SETUP->Interface* path:

GPIB Address 1 to 31

The instrument performs the following functions based on IEEE488 bus commands:

SH1, AH1, T5, L3, RL1, DC1

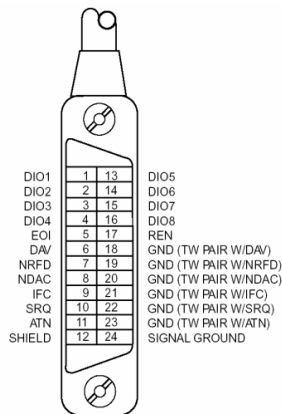

The instrument also recognizes the following general commands:
 DCL Device Clear - resets the instrument to its basic state
 SDC Selected Device Clear - resets the instrument to its basic state
 GTL Go To Local - switches the remote control off
 LLO Local Lock Out - switches the local control off, the instrument cannot be controlled from the front panel

Commands are identical to the commands for RS-232 interface. Detailed description is shown in chapter 8.2.

Figure 25 IEEE488 connector

6.3. LAN Interface (option)

LAN Interface allows communication with simulator using Telnet protocol. A proper setting must be established.

Following equipment is required:

- M641 simulator with LAN, USB, IEEE488 bus option
- Personal Computer (or other controlling device) with LAN interface
- LAN cable

The LAN interface must be selected from simulator system menu to be in operation (*SETUP->Interface->Active bus*). There are following LAN settings accessible from simulator system menu under *SETUP->Interface->LAN Settings* path (values are default ones):

DHCP	ON	
IP Address	192.168.001.100	only valid if DHCP is OFF
Subnet mask	255.255.255.000	only valid if DHCP is OFF
Default gateway	255.255.255.255	only valid if DHCP is OFF
Port number	23	
Host name	M641_SN620031	only valid if DHCP is ON

If DHCP (Dynamic Host Configuration Protocol) is enabled, the IP Address and all necessary settings are done automatically and connection in Telnet protocol is done via “Host name” and “Port number”. Otherwise the IP address, Subnet mask and Default gateway should be properly set. In this case connection is done via “IP Address” and “Port number”.

Connection to simulator box using Microsoft Telnet terminal with DHCP option enabled:

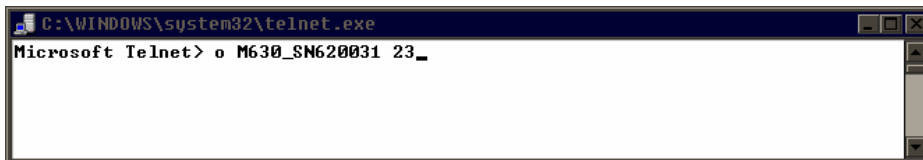

Figure 26 LAN connection 1

If connection is successful following screen will appear:



Figure 27 LAN connection 2

6.4. USB Interface (option)

The simulator can be controlled via USB (Universal Serial Bus) interface.

Following equipment is required:

- M641 simulator with LAN, USB, IEEE488 bus option
- Personal Computer (or other controlling device) with USB interface (USB type A connector)
- Standard USB A-B cable

The USB interface must be selected from simulator system menu to be in operation (*SETUP->Interface->Active bus*). There is no USB setting in the simulator.

Simulator is equipped with USB type B connector.

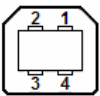

Pin	Label	Description
1	+5V	Power supply
2	DATA-	Data signal -
3	DATA+	Data signal +
4	GND	Ground

Figure 28 USB connector

Communication from user control program is performed via standard RS232 interface. Following settings should be set on your PC for proper operation:

Baudrate	9600 Bd
Data bits	8
Stop bits	1
Parity	None

Also proper COM port must be selected. After connecting simulator to your PC, virtual COM port should appear in System Control panel of Microsoft Windows OS. This COM port is labeled “USB Serial Port (COMxx)”.

6.5. Command syntax

The commands described in this chapter can be issued through all buses (RS232/GPIB/LAN/USB).

All commands listed in this chapter are explained in two columns:

KEYWORD and PARAMETERS.

KEYWORD column includes the name of the command. Each command includes one or more keywords. If a keyword is in brackets ([]), it is not mandatory. Non-mandatory commands are used only to achieve compatibility with language standard SCPI.

Capitals designate the abbreviated form of the commands; extended form is written in lowercase.

Command parameters are in brackets (<>); each parameter is separated using a comma. Parameters in brackets ([]) are not mandatory. Line (|) means “or” and is used to separate several alternative parameters.

Semicolon ‘;’ is used to separate more commands written on one line.

E.g. :RES 100;;OUTP ON

Terminators:

For GPIB interface each command line must end with <lf>. Response from the device also returns <lf>. For non GPIB interfaces <cr>, <lf> or <crlf> can be used as terminator. The device returns <crlf> in this case. The device performs all commands written on one line of the program after it receives terminator. Without terminator, the program line is not executed.

Description of abbreviations

<DNPD> = Decimal Numeric Program Data, this format is used to express decimal number with or without the exponent.

<CPD> = Character Program Data. Usually, it represents a group of alternative character parameters. E.g. {SERial|GPIB|USB|LAN}.

<SPD> = String Program Data (quoted string). This type of parameter is similar to CPD, but allows transmission of more ISO characters.

<BOOL> = Boolean Program Data. This type of parameter has only two states 0 and 1. Parameter can take form of integer value (0 or 1), or character alias (ON or OFF). Device always returns integer value (0 or 1).

<UNIT> = unit parameter works in conjunction with DNPD parameter and specifies unit of DNPD (numeric) value. Unit must be selected from predefined ones. If UNIT part is omitted, default one is used. Query always returns actual unit.

? = A flag indicating a request for the value of the parameter specified by the command. No other parameter than the question mark can be used.

(?) = A flag indicating a request for the parameter specified by the command. This command permits a value to be set as well as requested.

<cr> = carriage return. ASCII code 13. This code executes the program line.

<lf> = line feed. ASCII code 10. This code executes the program line.

6.6. SCPI Command Tree

This chapter summarizes all public SCPI commands supported by device in alphabetic order. Detailed description follows in next chapter.

```

:CALibration
  :RESistance
    :AMPLitude(?) <DNPd>
    :SElect(?) <DNPd>
  :SECure
    :PASSword(?) <DNPd>
    :EXIT
:DISPlay
  :ANNotation
    :CLOCK
      :DATE
        :FORMat(?) {MDYS|MDYA|DMYS|DMYO|DMYA|YMDS|YMDO}
        [:STATe](?) {ON|OFF|1|0}
      :BRIGHtness(?) <DNPd>
      :LANGUage(?) {ENGLish|DEUTsch|FRENch|RUSsian|SPANish|CZEChe}
  :OUTPut
    :SHORt(?) {ON|OFF|1|0}
    [:STATe](?) {ON|OFF|1|0}
    :SWITChing(?) {FAST|SMOoth|OPEN|SHORt}
[:SOURce]
  :NICKel
    [:AMPLitude](?) <DNPd>[{{CEL|FAR|K}}]
    :ZRESistance(?) <DNPd>[OHM]
  :PLATinum
    [:AMPLitude](?) <DNPd>[{{CEL|FAR|K}}]
    :COEFFicient(?) <DNPd>,<DNPd>,<DNPd>
    :STANdard(?) {PT385A|PT385B|PT3916|PT3926|USER}
    :ZRESistance(?) <DNPd>[OHM]
  :RESistance
    [:AMPLitude](?) <DNPd>[OHM]
  :TIMing
    :PCOunt? <DNPd>
    :PRESet
      :NAME(?) <SPD>
      :PCLear
      :RAPPend <SPD>
      :RCOunt? <DNPd>
      :ROW<IND_ROW>
        :AMPLitude(?) <SPD>
        :RDElete
      :SAVE
    :SElect(?) <DNPd>
  :UFUNction
    [:AMPLitude](?) <DNPd>
    :CURVe
      :SElect(?) <DNPd>
      :PCOunt? <DNPd>
      :PRESet
        :NAME(?) <SPD>
        :PCLear

```

```

:RAPPend <SPD>
:RCOunt? <DNPD>
:ROW<IND_ROW>
    :AMPLitude(?) <SPD>
    :RDElete
:SAVE
:UNIT(?) <SPD>
:STATus
    :OPERation
        :CONDition(?) <DNPD>
        :ENABle(?) <DNPD>
        [:EVENT]? <DNPD>
        :NTRansition(?) <DNPD>
        :PTRansition(?) <DNPD>
    :QUESTionable
        :CONDition(?) <DNPD>
        :ENABle(?) <DNPD>
        [:EVENT]? <DNPD>
        :NTRansition(?) <DNPD>
        :PTRansition(?) <DNPD>
:SYSTem
    :BEEPer
        :STATe(?) {ON|OFF|1|0}
        :VOLume(?) <DNPD>
    :COMMunicate
        :BUS(?) {SERial|GPIB|USB|LAN}
        :GPIB
            :ADDRes(?) <DNPD>
        :LAN
            :ADDRes(?) <CPD>
            :MASK(?) <CPD>
            :GATE(?) <CPD>
            :PORT(?) <DNPD>
            :HOST(?) <CPD>
            :DHCP(?) {ON|OFF|1|0}
        :REStart
        :SERial
            :BAUD(?) {1200|2400|4800|9600|19200|38400|57600|115200}
    :DATE(?) <DNPD>,<DNPD>,<DNPD>
    :ERRor
        [:NEXT]? <CPD>
    :KEY(?) <DNPD>
    :LOCal
    :PRESet
    :REMote
    :RWLock
    :TIME(?) <DNPD>,<DNPD>,<DNPD>
    :VERSion? <CPD>
:UNIT
    :TEMPerature(?) {CEL|FAR|K}
*CLS
*ESE(?)
*ESR?
*IDN?
*OPC(?)

```

- *OPT?
- *RST
- *SRE(?)
- *STB?
- *TST?
- *WAI

6.7. Standard Status Data Structures

RTD simulator meets standard protocol according to the standard IEEE488.2. The protocol can be used for checking of error and status behavior of the device. It enables single-wire transmitting of SRQ command. The conditions on which SRQ signal (local control request) is sent can be set with parameters *STB?, *SRE?, *SRE, *ESR?, *ESE?, *ESE a *CLS.

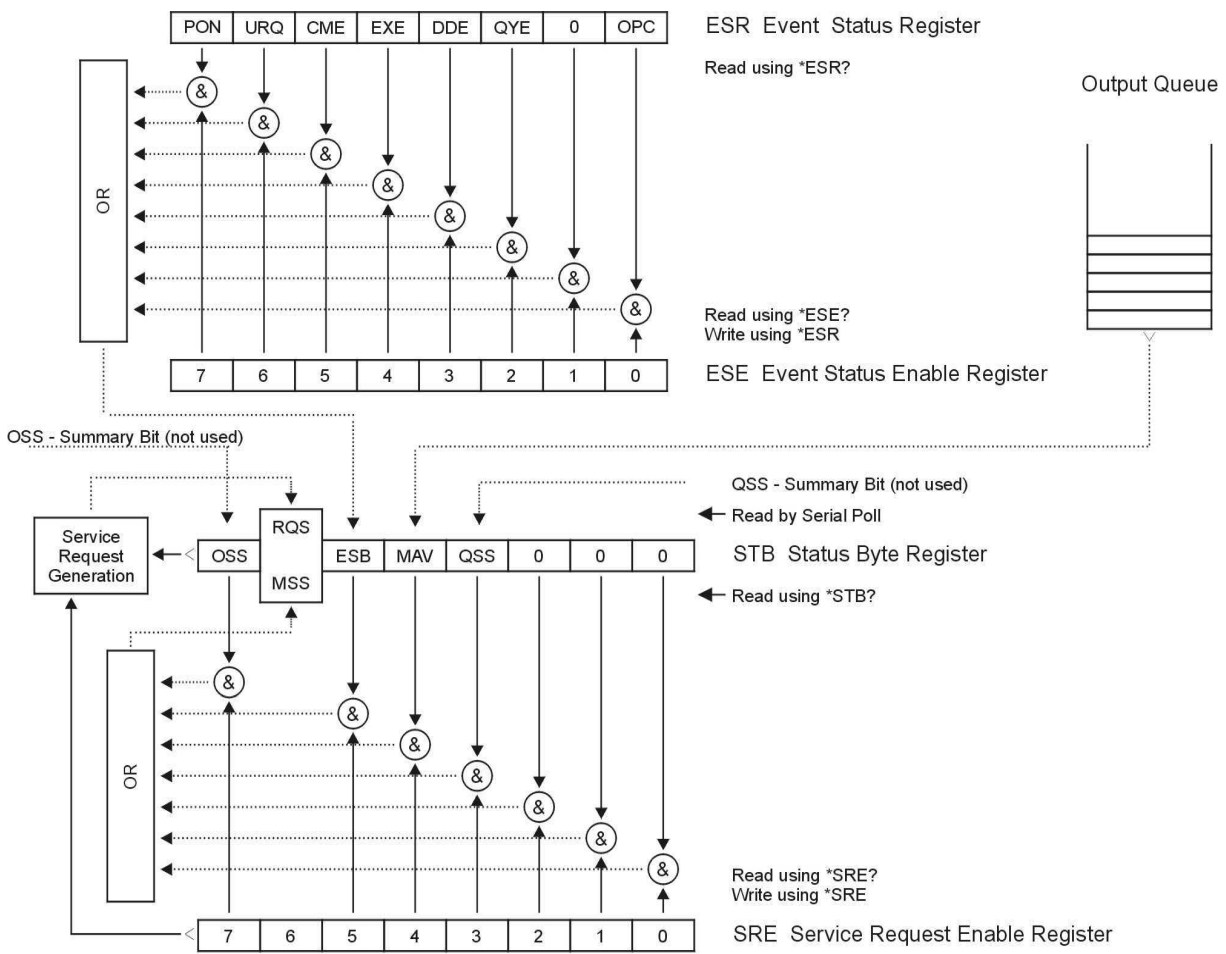

Status Register Overview

Figure 29 Status register overview

Status data structure contains following registers:

STB – Status Byte Register
 SRE – Service Request Enable Register
 ESR – Event Status Register
 ESE – Event Status Enable Register
 Output Queue

STB Status Byte Register

STB is main register where information from other status registers and from output queue is collected. Value of STB register is reset after switching on the device or after sending command *CLS. This command reset the STB register except bit MAV, which remains set if the output queue is not empty. STB register value can be read via serial message or through general query *STB?.

Bit configuration of Status Byte Register:

- OSS Operation Summary Status, bit 7. SCPI-defined. The OSS bit is set to 1 when the data in the OSR (Operation Status Register) contains one or more enabled bits which are true.
- RQS Request Service, bit 6. The bit is read as a part of status byte only when serial message is sent.
- MSS Master Summary Status, bit 6. The MSS bit is set to 1 whenever bits ESB or MAV are 1 and enabled (1) in the SRE. This bit can be read using the *STB? command. Its value is derived from STB and SRE status.
- ESB Event Summary Bit, bit 5. His value is derived from STB and SRE status. The ESB bit is set to 1 when one or more enabled ESR bits are set to 1.
- MAV Message Available, bit 4. The MAV bit is set to 1 whenever data is available in the IEEE488 Output Queue (the response on query is ready).
- QSS Questionable Summary Status, bit 3. SCPI-defined. The QSS bit is set to 1 when the data in the QSR (Questionable Status Register) contains one or more enabled bits which are true.

SRE Service Request Enable Register

The Service Request Enable Register suppresses or allows the STB bits. “0” value of a SRE bit means, that the bit does not influence value of MSS bit. Value of any unmasked STB bit results in setting of the MSS bit to the level “1”. SRE bit 6 is not influenced and its value is “0”. The SRE register value can be set via the command *SRE followed by mask register value (0 – 191). The register can be read with the command *SRE?. The register is automatically resets after switching the simulator on. The register is not reset by the command *CLS.

ESR Event Status Register

Every bit of the EventStatusRegister corresponds to one event. Bit is set when the event is changed and it remains set also when the event passed. The ESR is cleared when the power is turned on (except bit PON which is set), and every time it is read via command *ESR? Or cleared with *CLS.

Bit configuration of Event Status Register:

- PON Power On, bit 7. This event bit indicates that an off-to-on transition has occurred in the device’s power supply.
- URQ User Request, bit 6. Bit is not used and it is always “0”.
- CME Command Error, bit 5. This event bit indicates that an incorrectly formed command or query has been detected by the instrument.
- EXE Execution Error, bit 4. This event bit indicates that the received command cannot be executed, owing to the device state or the command parameter being out of limits.
- DDE Device Dependent Error, bit 3. This event bit indicates that an error has occurred which is neither a Command Error, a Query Error, nor an Execution Error. A Device-specific Error is any executed device operation that did not properly complete due to some condition, such as overload.
- QYE Query Error, bit 2. The bit is set if the simulator is addressed as talker and output queue is empty or if control unit did not pick up response before sending next query.

OPC Operation Complete, bit 0. This event bit is generated in response to the *OPC command. It indicates that the device has completed all selected pending operations.

ESE Event Status Enable Register

The Event Status Enable Register allows one or more events in the Event Status Register to be reflected in the ESB summary-message bit. This register is defined for 8 bits, each corresponding to the bits in the Event Status Register. The Event Status Enable Register is read with the common query *ESE?. Data is returned as a binary-weighted value. The Event Status Enable Register is written to by the common command, *ESE. Sending the *ESE common command followed by a zero clears the ESE. The Event Status Enable Register is cleared upon power-on.

It suppresses or allows bits in ESR register. Value „0“ of a bit of ESE register suppresses influence of appropriate bit of ESR register on value of sum bit of ESB status register. Setting of any unmask bit of ESR register results in setting of ESB status register. ESE register value can be modified by command *ESE followed by value of mask register (integer in range 0 –255). Reading of the register can be performed with command *ESE?. The register is automatically reset after switching on. The register is not reset with *CLS command.

Operation Status Register

Not used in the simulator.

Questionable Status Register

Not used in the simulator.

Output Queue

The Output Queue stores response messages until they are read from control unit. If there is at minimum one sign in the output queue, MAV register (message available) is set. The Output Queue is cleared upon power-on and after reading all signs from output queue.

Error Queue

The Error Queue stores error messages. They are placed in a “first in, first out” queue. The queue is read destructively using the query command “SYSTem:ERRor?” to obtain a code number and error message. The query “SYSTem:ERRor?” can be used to read errors in the queue until it is empty, when the message “0, No Error” will be returned.

6.8. SCPI Standard Commands

This chapter describes standard SCPI commands.

***IDN?**

Syntax:

*IDN?

Description:

This command returns the identification of the manufacturer, model, serial number and firmware revision.

Parameters:

<CPD> manufacturer
<CPD> model
<DNPD> serial number
<DNPD> firmware version

Remarks:

Overlapped command

Example:

*IDN? Response: MEATEST,M641,620151,1.00

***OPC**

Syntax:

*OPC

Description:

This command sets the OPC bit in the ESR (Event Status Register) when all pending operations are complete.

Parameters:

None

Remarks:

Overlapped command

Example:

*OPC

***OPC?**

Syntax:

*OPC?

Description:

This command returns "1" to the output queue after all pending operations inside simulator are complete.

Parameters:

<DNPD> always returns 1

Remarks:

Sequential command

Example:

*OPC? Response: 1

***OPT?**

Syntax:

*OPT?

Description:

This command return the instrument's hardware fitment. The only parameter returns presence of GPIB/LAN/USB interface.

Parameters:

<DNPD> 0 – extended interface not present, 1 – extended interface present

Remarks:

Overlapped command

Example:

*OPT? Response: 1

***WAI**

Syntax:

*WAI

Description:

Prevents the instrument from executing any further commands or queries until all previous remote commands have been executed.

Parameters:

None

Remarks:

Sequential command

Example:

*WAI

***RST**

Syntax:

*RST

Description:

This command resets the device to its initial factory-set state. This state may be different from the “Startup” preset.

Parameters:

None

Remarks:

Sequential command

Example:

*RST

***TST?**

Syntax:

*TST?

Description:

This command launches internal self-test and returns result.

Parameters:

<DNPD> 0 – test passed, 1 – test failed

Remarks:

Sequential command

Example:

*TST? Response: 0

***STB?**

Syntax:

*STB?

Description:

This query returns content of register STB, which carries the MSS bit status.

Parameters:

<DNPD> Status byte register, Range 0 ... 255

Remarks:

Overlapped command

Example:

*STB? Response: 0

***SRE**

Syntax:

*SRE

*SRE?

Description:

This command allows set condition of the Service Request Enable register. Since bit 6 is not used, the maximum value is 191.

Parameters:

<DNPD> Service Request Enable register

Remarks:

Overlapped command

Example:

*SRE 2

*SRE? Response: 2

***ESR?**

Syntax:

*ESR?

Description:

This query returns the contents of the Event Status Register and clears the register.

Parameters:

<DNPD> Event Status Register

Remarks:

Overlapped command

Example:

*ESR? Response: 0

***ESE**

Syntax:

*ESE

*ESE?

Description:

This command programs the Event Status Enable register bits.

Parameters:

<DNPD> Event Status Enable register, Range 0 ... 255

Remarks:

Overlapped command

Example:

*ESE 2

*ESE? Response: 2

***CLS**

Syntax:

*CLS

Description:

This command clears all status data structures in the device i.e. Event Status Register, Status Byte Register except the MAV bit, Operation Status Register, Questionable Status Register. Also error queue is cleared. Output queue is unaffected.

Parameters:

None

Remarks:

Overlapped command

Example:

*CLS

6.9. SCPI Commands

This chapters describes all public SCPI commands in detailed form. The commands here are in alphabetic order.

:CALibration:RESistance:AMPLitude

Syntax:

```
:CALibration:RESistance:AMPLitude <DNPD>
```

```
:CALibration:RESistance:AMPLitude?
```

Description:

This command sets calibration value of particular internal resistance standard at output terminals including all parasitic resistances inside simulator.

Parameters:

<DNPD> Standard resistance value in Ohms. Ranges and default values varies in accordance to selected resistance etalon (see table "Calibration points M641").

Remarks:

This command requires "Calibration" access
Overlapped command
Value is not affected by reset or by *RST command

Example:

```
CAL:RES:AMPL 1.944
```

```
CAL:RES:AMPL? Response: 1.944000E+00
```

:CALibration:RESistance:SElect

Syntax:

```
:CALibration:RESistance:SElect <DNPD>
```

```
:CALibration:RESistance:SElect?
```

Description:

This command enters calibration mode and selects internal resistance standard for calibration. Output terminals are automatically switched-on.

Parameters:

<DNPD> Range 1 ... Max. Resistance Count, one based index of resistance standard

Remarks:

This command requires "Calibration" access
Overlapped command

Example:

```
CAL:RES:SEL 1
```

```
CAL:RES:SEL? Response: 1
```

:CALibration:SECure:PASSword

Syntax:

:CALibration:SECure:PASSword <DNPD>

Description:

This command validates entered password and enables calibration access if verification is successful. Access is invalidated after reset or if CAL:SEC:EXIT command is issued. Calibration password can be changed from simulator system menu *SETUP->Calibration->Change password*.

Parameters:

<DNPD> Range 0 ... 4294967295 (default 0)

Remarks:

Overlapped command

Example:

CAL:SEC:PASS 0

:CALibration:SECure:EXIT

Syntax:

:CALibration:SECure:EXIT

Description:

This command exits calibration mode and access.

Parameters:

None

Remarks:

Overlapped command

Example:

CAL:SEC:EXIT

:DISPlay:ANNotation:CLOCK:DATE:FORMat

Syntax:

:DISPlay:ANNotation:CLOCK:DATE:FORMat <CPD>

:DISPlay:ANNotation:CLOCK:DATE:FORMat?

Description:

This command sets format of date displayed on device screen.

Parameters:

<CPD> {MDYS|MDYA|DMYS|DMYO|DMYA|YMDS|YMDO} (default MDYS)

·MDYS M/D/Y format (M-month, D-day, Y-year)

·MDYA M-D-Y format

·DMYS D/M/Y format

·DMYO D.M.Y format

·DMYA D-M-Y format

·YMDS Y/M/D format

·YMDO Y.M.D format

Remarks:

Overlapped command

Value is not affected by reset or by *RST command

Example:

DISP:ANN:CLOC:DATE:FORM MDYS

DISP:ANN:CLOC:DATE:FORM? Response: MDYS

:DISPlay:ANNotation:CLOCK[:STATe]

Syntax:

```
:DISPlay:ANNotation:CLOCK[:STATe] <BOOL>
:DISPlay:ANNotation:CLOCK[:STATe]?
```

Description:

This command enables/disables showing actual time in title on device screen

Parameters:

<BOOL>	{ ON OFF 1 0} (default 1)
·ON	actual time is shown
·OFF	actual time is hidden
·1	same as ON
·0	same as OFF

Remarks:

Overlapped command

Value is not affected by reset or by *RST command

Example:

```
DISP:ANN:CLOC ON
DISP:ANN:CLOC? Response: 1
```

:DISPlay:BRIGhtness

Syntax:

```
:DISPlay:BRIGhtness <DNPD>
:DISPlay:BRIGhtness?
```

Description:

This command sets brightness of device display.

Parameters:

<DNPD>	Range 0.0 ... 1.0 (default 1.0), 0.0 – Min, 1.0 – Max brightness
--------	--

Remarks:

Overlapped command

Value is not affected by reset or by *RST command

Example:

```
DISP:BRIG 1.0
DISP:BRIG? Response: 1.000000E+00
```

:DISPlay:LANGUage

Syntax:

```
:DISPlay:LANGUage <CPD>
:DISPlay:LANGUage?
```

Description:

This command sets language that is used on device display.

Parameters:

<CPD>	{ ENGLish DEUTsch FRENch RUSSian SPANish CZECh } (default ENGL)
·ENGLish	english version
·DEUTsch	german version
·FRENch	french version
·RUSSian	russian version
·SPANish	spanish version
·CZECh	czech version

Remarks:

Overlapped command

Value is not affected by reset or by *RST command

Example:

```
DISP:LANG ENGL
DISP:LANG? Response: ENGL
```

:OUTPut:SHORT

Syntax:

```
:OUTPut:SHORT <BOOL>
:OUTPut:SHORT?
```

Description:

This command turns on short function. "Short" is activated only if output terminals are switched on (see OUTP:STAT command).

Parameters:

```
<BOOL>          { ON|OFF|1|0 } (default 0)
  .ON            short is set if output is on
  .OFF          resistance is set if output is on
  .1            same as ON
  .0            same as OFF
```

Remarks:

Overlapped command
Value is set to default on reset and on *RST command

Example:

```
OUTP:SHOR ON
OUTP ON
OUTP:SHOR? Response: 1
```

:OUTPut[:STATe]

Syntax:

```
:OUTPut[:STATe] <BOOL>
:OUTPut[:STATe]?
```

Description:

This command switches ON/OFF output terminals. This command operates in conjunction with OUTP:SHOR command:

<i>OUTP:STAT</i>	<i>OUTP:SHOR</i>	<i>Output terminals</i>
OFF	OFF	Open
OFF	ON	Open
ON	OFF	Resistance
ON	ON	Short

Table 4 OUTPut command structure

Parameters:

```
<BOOL>          { ON|OFF|1|0 } (default 0)
  .ON            output terminals are switched on
  .OFF          output terminals are switched off
  .1            same as ON
  .0            same as OFF
```

Remarks:

Overlapped command
Value is set to default on reset and on *RST command

Example:

```
OUTP ON
OUTP? Response: 1
```

:OUTPut:SWITching

Syntax:

```
:OUTPut:SWITching <CPD>
:OUTPut:SWITching?
```

Description:

If output amplitude is changed and output terminals are already switched on, some glitches appear at output terminals. This setting allows selecting a method how new resistance at output terminals is achieved.

Parameters:

```
<CPD>          {FAST|SMOoth|OPEN|SHORT} (default FAST)
  ·FAST        new resistance is set as fast as possible
  ·SMOoth      new resistance is set with minimal output changes
  ·OPEN        open function is activated before new resistance is set
  ·SHORT       short function is activated before new resistance is set
```

Remarks:

Overlapped command

Value is set according to “Startup” preset on restart and to default on *RST command

Example:

```
OUTP:SWIT FAST
OUTP:SWIT? Response: FAST
```

[:SOURce]:NICKel[:AMPLitude]

Syntax:

```
[ :SOURce]:NICKel[:AMPLitude] <DNPd>[<UNIT>]
[ :SOURce]:NICKel[:AMPLitude]?
```

Description:

This command sets temperature in Nickel mode. Node SOUR:NICK also selects “NICKEL” function if not already selected. If unit parameter is part of temperature, new unit is set.

Parameters:

```
<DNPd>          temperature at Nickel function. Default value is 100.0 °C.
<UNIT>          {CEL|FAR|K}
  ·CEL          degrees of Celsius
  ·FAR          degrees of Fahrenheit
  ·K            Kelvin
```

Remarks:

Overlapped command

Value is set according to “Startup” preset on restart and to default on *RST command

Example:

```
NICK 100.0
NICK? Response: 1.000000E+02 CEL
```

[[:SOURce]:NICKel:ZRESistance

Syntax:

```
[[:SOURce]:NICKel:ZRESistance <DNPd>[<UNIT>]
[:SOURce]:NICKel:ZRESistance?
```

Description:

This command sets resistance at 0 °C for Nickel function.

Parameters:

```
<DNPd>          Range 100.0 ... 1000.0 (default 100.0).
<UNIT>          { OHM }
                ·OHM
```

Remarks:

Overlapped command

Value is set according to “Startup” preset on restart and to default on *RST command

Example:

```
NICK:ZRES 100.0
NICK:ZRES? Response: 1.000000E+02 OHM
```

[[:SOURce]:PLATinum[:AMPLitude]

Syntax:

```
[[:SOURce]:PLATinum[:AMPLitude] <DNPd>[<UNIT>]
[:SOURce]:PLATinum[:AMPLitude]?
```

Description:

This command sets temperature in Platinum mode. Node SOUR:PLAT also selects “PLATINUM” function if not already selected. If unit parameter is part of temperature, new unit is set.

Parameters:

```
<DNPd>          temperature at Platinum function. Default value is 100.0 °C.
<UNIT>          { CEL|FAR|K }
                ·CEL      degrees of Celsius
                ·FAR      degrees of Fahrenheit
                ·K         Kelvin
```

Remarks:

Overlapped command

Value is set according to “Startup” preset on restart and to default on *RST command

Example:

```
PLAT 100.0
PLAT? Response: 1.000000E+02 CEL
```

[[:SOURce]:PLATinum:COEFFicient

Syntax:

```
[[:SOURce]:PLATinum:COEFFicient <DNPd>,<DNPd>,<DNPd>
[:SOURce]:PLATinum:COEFFicient?
```

Description:

This command allows to define Coefficients (A, B, C) used for “User” Platinum standard scale.

Parameters:

```
<DNPd>          Range 3.0e-3 ... 5.0e-3 (default 3.9083e-3), Coefficient A
<DNPd>          Range -7.0e-7 ... -5.0e-7 (default -5.775e-7), Coefficient B
<DNPd>          Range -5.0e-12 ... -3.0e-12 (default -4.18301e-12), Coefficient C
```

Remarks:

Overlapped command

Value is set according to “Startup” preset on restart and to default on *RST command

Example:

```
PLAT:COEF 3.9083e-3,-5.775e-7,-4.18301e-12
PLAT:COEF? Response: 3.908300E-03,-5.775000E-07,-4.183010E-12
```

[[:SOURce]:PLATinum:STANdard

Syntax:

```
[[:SOURce]:PLATinum:STANdard <CPD>
[:SOURce]:PLATinum:STANdard?
```

Description:

This command selects Platinum temperature standard.

Parameters:

```
<CPD>      {PT385A|PT385B|PT3916|PT3926|USER} (default PT385A)
·PT385A    Pt385 (68) standard
·PT385B    Pt385 (90) standard
·PT3916    Pt3916 standard
·PT3926    Pt3926 standard
·USER      User (see PLAT:COEF command)
```

Remarks:

Overlapped command

Value is set according to “Startup” preset on restart and to default on *RST command

Example:

```
PLAT:STAN PT385A
PLAT:STAN? Response: PT385A
```

[[:SOURce]:PLATinum:ZRESistance

Syntax:

```
[[:SOURce]:PLATinum:ZRESistance <DNPD>[<UNIT>]
[:SOURce]:PLATinum:ZRESistance?
```

Description:

This command sets resistance at 0 °C for Platinum function.

Parameters:

```
<DNPD>      Range 100.0 ... 1000.0 (default 100.0).
<UNIT>      {OHM}
·OHM
```

Remarks:

Overlapped command

Value is set according to “Startup” preset on restart and to default on *RST command

Example:

```
PLAT:ZRES 100.0
PLAT:ZRES? Response: 1.000000E+02 OHM
```

[[:SOURce]:RESistance[:AMPLitude]

Syntax:

```
[[:SOURce]:RESistance[:AMPLitude] <DNPD>[<UNIT>]
[:SOURce]:RESistance[:AMPLitude]?
```

Description:

This command sets amplitude in Resistance mode. Node SOUR:RES also selects “RESISTANCE” function if not already selected. Optionally unit can be enclosed.

Parameters:

```
<DNPD>      Range 10.0 ... 300.0e3, default 100.0
<UNIT>      {OHM}
·OHM
```

Remarks:

Overlapped command

Value is set according to “Startup” preset on restart and to default on *RST command

Example:

```
RES 100.0
RES? Response: 1.000000E+02 OHM
```

[[:SOURce]:TIMing:PCOunt?

Syntax:

[:SOURce]:TIMing:PCOunt?

Description:

This command retrieves maximum number of timing sequences. This number represents maximum index used in sequence commands.

Parameters:

<DNPD> Integer value representing maximum sequence count

Remarks:

Overlapped command

Example:

TIM:PCO? Response: 64

[[:SOURce]:TIMing:PRESet:NAME

Syntax:

[:SOURce]:TIMing:PRESet:NAME <SPD>

[:SOURce]:TIMing:PRESet:NAME?

Description:

This command allows reading and changing sequence name. Data will be saved to non-volatile memory on TIM:PRES:SAVE command.

Parameters:

<SPD> Quoted sequence name. Upper alpha, lower alpha, digits and spaces are allowed. Maximum string size is 8 characters.

Remarks:

Overlapped command

Example:

TIM:PRES:NAME "TIME 1s"

TIM:PRES:NAME? Response: "TIME 1s"

[[:SOURce]:TIMing:PRESet:PCLear

Syntax:

[:SOURce]:TIMing:PRESet:PCLear

Description:

This command clears existing sequence data including its timing table. Data will be saved to non-volatile memory on TIM:PRES:SAVE command.

Parameters:

None

Remarks:

Overlapped command

Example:

TIM:PRES:PCL

[[:SOURce]:TIMing:PRESet:RAPPend

Syntax:

[:SOURce]:TIMing:PRESet:RAPPend <SPD>

Description:

This command appends new record at the end of timing table. Data will be saved to non-volatile memory on TIM:PRES:SAVE command.

Parameters:

<SPD> Quoted string representing amplitude. The amplitude consists of two float numeric fields separated by comma. The first one represents timing interval in seconds and the second one amplitude in Ohms.

Remarks:

Overlapped command

Example:

TIM:PRES:RAPP "0.5,220.0"

[[:SOURce]:TIMing:PRESet:RCOunt?

Syntax:

[:SOURce]:TIMing:PRESet:RCOunt?

Description:

This commands returns actual number of records in timing table.

Parameters:

<DNPD> Integer value representing number of records

Remarks:

Overlapped command

Example:

TIM:PRES:RCO? Response: 6

[[:SOURce]:TIMing:PRESet:ROW<IND_ROW>:AMPLitude

Syntax:

[:SOURce]:TIMing:PRESet:ROW<IND_ROW>:AMPLitude <SPD>

[:SOURce]:TIMing:PRESet:ROW<IND_ROW>:AMPLitude?

Description:

This command sets / retrieves selected row in timing table. Data will be saved to non-volatile memory on TIM:PRES:SAVE command.

Parameters:

<IND_ROW> Range 1 ... Row count (1 - if omitted)
<SPD> Quoted string representing amplitude. The amplitude consists of two float numeric fields separated by comma. The first one represents timing interval in seconds and the second one amplitude in Ohms.

Remarks:

Overlapped command

Example:

TIM:PRES:ROW1:AMPL "0.5,220.0"

TIM:PRES:ROW1:AMPL? Response: " 5.000000E-01,2.200000E+02"

[[:SOURce]:TIMing:PRESet:ROW<IND_ROW>:RDELete

Syntax:

[:SOURce]:TIMing:PRESet:ROW<IND_ROW>:RDELete

Description:

This command deletes row from timing table. Data will be saved to non-volatile memory on TIM:PRES:SAVE command.

Parameters:

<IND_ROW> Range 1 ... Row count (1 - if omitted)

Remarks:

Overlapped command

Example:

TIM:PRES:ROW1:RDEL

[[:SOURce]:TIMing:PRESet:SAVE

Syntax:

[:SOURce]:TIMing:PRESet:SAVE

Description:

This command saves current sequence to non-volatile memory. Unsaved changes will disappear on restart, function change or selection of another sequence.

Parameters:

None

Remarks:

Overlapped command

Example:

TIM:PRES:SAVE

[[:SOURce]:TIMing:SELEct

Syntax:

[:SOURce]:TIMing:SELEct <DNPD>

[:SOURce]:TIMing:SELEct?

Description:

This command selects timing sequence. Selected sequence is shown on device display, can be executed using OUTP ON command and can be edited using SOUR:TIM:PRES group of commands.

Parameters:

<DNPD> Range 1 ... 64 – maximum sequence count (default 1), one based index of sequence

Remarks:

Overlapped command

Value is set according to “Startup” preset on restart and to default on *RST command

Example:

TIM:SEL 1

TIM:SEL? Response: 1

[[:SOURce]:UFUNction[:AMPLitude]

Syntax:

```
[[:SOURce]:UFUNction[:AMPLitude] <DNPD>
[:SOURce]:UFUNction[:AMPLitude]?
```

Description:

This command sets amplitude in USER FUNCTION mode. Node SOUR:UFUN also selects “USER FUNCTION” function if not already selected.

Parameters:

<DNPD> Range depends on translation curve, default value is 1.0 or minimal value that can be set

Remarks:

Overlapped command

Value is set according to “Startup” preset on restart and to default on *RST command

Example:

```
UFUN 1.0
UFUN? Response: 1.000000E+00
```

[[:SOURce]:UFUNction:CURVe:SElect

Syntax:

```
[[:SOURce]:UFUNction:CURVe:SElect <DNPD>
[:SOURce]:UFUNction:CURVe:SElect?
```

Description:

This command selects conversion curve. Selected curve is activated on device display and can be edited using SOUR:UFUN:CURV:PRES group of commands.

Parameters:

<DNPD> Range 1 ... 64 – Maximum curve count (default 1), one based index of curve

Remarks:

Overlapped command

Value is set according to “Startup” preset on restart and to default on *RST command

Example:

```
UFUN:CURV:SEL 1
UFUN:CURV:SEL? Response: 1
```

[[:SOURce]:UFUNction:CURVe:PCOunt?

Syntax:

```
[[:SOURce]:UFUNction:CURVe:PCOunt?
```

Description:

This command retrieves maximum number of user function presets. This number represents maximum index used in preset commands.

Parameters:

<DNPD> Integer value representing maximum number of curves

Remarks:

Overlapped command

Example:

```
UFUN:CURV:PCO? Response: 64
```

[[:SOURce]:UFUNction:CURVe:PRESet:NAME

Syntax:

```
[[:SOURce]:UFUNction:CURVe:PRESet:NAME <SPD>
[:SOURce]:UFUNction:CURVe:PRESet:NAME?
```

Description:

This command allows reading and changing selected curve name. Data will be saved to non-volatile memory on UFUN:CURV:PRES:SAVE command.

Parameters:

<SPD> Quoted curve name. Upper alpha, lower alpha, digits and spaces are allowable. Maximum string size is 8 characters.

Remarks:

Overlapped command

Example:

```
UFUN:CURV:PRES:NAME "CURVE 2"
UFUN:CURV:PRES:NAME? Response: "CURVE 2"
```

[[:SOURce]:UFUNction:CURVe:PRESet:PCLearn

Syntax:

```
[[:SOURce]:UFUNction:CURVe:PRESet:PCLearn
```

Description:

This command deletes existing curve including its lookup table. Data will be saved to non-volatile memory on UFUN:CURV:PRES:SAVE command.

Parameters:

None

Remarks:

Overlapped command

Example:

```
UFUN:CURV:PRES:PCL
```

[[:SOURce]:UFUNction:CURVe:PRESet:RAPPend

Syntax:

```
[[:SOURce]:UFUNction:CURVe:PRESet:RAPPend <SPD>
```

Description:

This command appends new record at the end of lookup table. Data will be saved to non-volatile memory on UFUN:CURV:PRES:SAVE command.

Parameters:

<SPD> Quoted string representing amplitude. The amplitude consists of two float numeric fields separated by comma. The first one represents amplitude in "User Function" units and the second one amplitude in Ohms.

Remarks:

Overlapped command

Example:

```
UFUN:CURV:PRES:RAPP "10.6,220.0"
```

[[:SOURce]:UFUNction:CURVe:PRESet:RCOunt?

Syntax:

[:SOURce]:UFUNction:CURVe:PRESet:RCOunt?

Description:

This commands returns actual number of records in curve table.

Parameters:

<DNPD> Integer value representing number of records for particular curve table

Remarks:

Overlapped command

Example:

UFUN:CURV:PRES:RCO? Response: 2

[[:SOURce]:UFUNction:CURVe:PRESet:ROW<IND_ROW>:AMPLitude

Syntax:

[:SOURce]:UFUNction:CURVe:PRESet:ROW<IND_ROW>:AMPLitude <SPD>

[:SOURce]:UFUNction:CURVe:PRESet:ROW<IND_ROW>:AMPLitude?

Description:

This command sets / retrieves selected row in curve table. Data will be saved to non-volatile memory on UFUN:CURV:PRES:SAVE command.

Parameters:

<IND_ROW> Range 1 ... Row count (1 - if omitted)

<SPD> Quoted string representing amplitude. The amplitude consists of two float numeric fields separated by comma. The first one represents amplitude in "User Function" units and the second one amplitude in Ohms.

Remarks:

Overlapped command

Example:

UFUN:CURV:PRES:ROW1:AMPL "10.6,220.0"

UFUN:CURV:PRES:ROW1:AMPL? Response: "1.060000E+01,2.200000E+2"

[[:SOURce]:UFUNction:CURVe:PRESet:ROW<IND_ROW>:RDELete

Syntax:

[:SOURce]:UFUNction:CURVe:PRESet:ROW<IND_ROW>:RDELete

Description:

This command deletes row from curve table. Data will be saved to non-volatile memory on UFUN:CURV:PRES:SAVE command.

Parameters:

<IND_ROW> Range 1 ... Row count (1 - if omitted)

Remarks:

Overlapped command

Example:

UFUN:CURV:PRES:ROW1:RDEL

[[:SOURce]:UFUNction:CURVe:PRESet:SAVE

Syntax:

[:SOURce]:UFUNction:CURVe:PRESet:SAVE

Description:

This command saves current curve to non-volatile memory. Unsaved changes will disappear on restart, function change or selection of another curve.

Parameters:

None

Remarks:

Overlapped command

Example:

UFUN:CURV:PRES:SAVE

[[:SOURce]:UFUNction:CURVe:PRESet:UNIT

Syntax:

[:SOURce]:UFUNction:CURVe:PRESet:UNIT <SPD>

[:SOURce]:UFUNction:CURVe:PRESet:UNIT?

Description:

This command sets / retrieves unit of selected curve. Data will be saved to non-volatile memory on UFUN:CURV:PRES:SAVE command.

Parameters:

<SPD> Quoted user function unit. Upper alpha, lower alpha, digits and spaces are allowable. Maximum string size is 2 characters.

Remarks:

Overlapped command

Example:

UFUN:CURV:PRES:UNIT "N"

UFUN:CURV:PRES:UNIT? Response: "N"

:STATus:OPERation:CONDition

Syntax:

:STATus:OPERation:CONDition?

Description:

This query returns the content of Operational Condition register. It is a decimal value which corresponds to the binary-weighted sum of all bits in the register. Register is not cleared after this query. The response to the query therefore represents an instantaneous 'Snapshot' of the register state, at the time that the query was accepted.

Parameters:

<DNPD> Operational Condition register

Remarks:

Overlapped command

Example:

STAT:OPER:COND? Response: 2

:STATus:OPERation:ENABle

Syntax:

```
:STATus:OPERation:ENABle <DNPd>
:STATus:OPERation:ENABle?
```

Description:

This command enables bits in the Operational Data Enable register. Selected bits are summarized at bit 7 (OSS) of the IEEE488.2 Status Byte register.

Parameters:

```
<DNPd>          Operational Data Enable register
```

Remarks:

Overlapped command

Example:

```
STAT:OPER:ENAB 2
STAT:OPER:ENAB? Response: 2
```

:STATus:OPERation[:EVENT]?

Syntax:

```
:STATus:OPERation[:EVENT]?
```

Description:

This query returns the content of Operational Data Event register. It is a decimal value which corresponds to the binary-weighted sum of all bits set in the register. Register is cleared after this query.

Parameters:

```
<DNPd>          Operational Data Event register
```

Remarks:

Overlapped command

Example:

```
STAT:OPER? Response: 0
```

:STATus:OPERation:NTRansition

Syntax:

```
:STATus:OPERation:NTRansition <DNPd>
:STATus:OPERation:NTRansition?
```

Description:

This command allows set Operation Negative Transition Register. It is a decimal value which corresponds to the binary-weighted sum of all bits set in the register. Setting a bit in the negative transition filter shall cause a 1 to 0 transition in the corresponding bit of the associated condition register to cause a 1 to be written in the associated bit of the corresponding event register.

Parameters:

```
<DNPd>          Operation Negative Transition Register, Range 0... 32767
```

Remarks:

Overlapped command

Example:

```
STAT:OPER:NTR 2
STAT:OPER:NTR? Response: 2
```

:STATus:OPERation:PTRansition

Syntax:

```
:STATus:OPERation:PTRansition <DNPD>
:STATus:OPERation:PTRansition?
```

Description:

This command allows set Operation Positive Transition Register. It is a decimal value which corresponds to the binary-weighted sum of all bits set in the register. Setting a bit in the positive transition filter shall cause a 0 to 1 transition in the corresponding bit of the associated condition register to cause a 1 to be written in the associated bit of the corresponding event register.

Parameters:

```
<DNPD>          Operation Positive Transition Register, Range 0 ... 32767
```

Remarks:

Overlapped command

Example:

```
STAT:OPER:PTR 1.0
STAT:OPER:PTR? Response: 1.000000E+00
```

:STATus:QUEStionable:CONDition

Syntax:

```
:STATus:QUEStionable:CONDition?
```

Description:

This query returns the content of Questionable Condition register. It is a decimal value which corresponds to the binary-weighted sum of all bits in the register. Register is not cleared after this query. The response to the query therefore represents an instantaneous 'Snapshot' of the register state, at the time that the query was accepted.

Parameters:

```
<DNPD>          Questionable Condition register
```

Remarks:

Overlapped command

Example:

```
STAT:QUES:COND? Response: 2
```

:STATus:QUEStionable:ENABle

Syntax:

```
:STATus:QUEStionable:ENABle <DNPD>
:STATus:QUEStionable:ENABle?
```

Description:

This command enables bits in the Questionable Data Enable register. Selected bits are summarized at bit 3 (QSS) of the IEEE488.2 Status Byte register.

Parameters:

```
<DNPD>          Questionable Data Enable register
```

Remarks:

Overlapped command

Example:

```
STAT:QUES:ENAB 2
STAT:QUES:ENAB? Response: 2
```

:STATus:QUEStionable[:EVENT]?

Syntax:

:STATus:QUEStionable[:EVENT]?

Description:

This query returns the content of Questionable Data Event register. It is a decimal value which corresponds to the binary-weighted sum of all bits set in the register. Register is cleared after this query.

Parameters:

<DNPD> Questionable Data Event register

Remarks:

Overlapped command

Example:

STAT:QUES? Response: 0

:STATus:QUEStionable:NTRansition

Syntax:

:STATus:QUEStionable:NTRansition <DNPD>

:STATus:QUEStionable:NTRansition?

Description:

This command allows set Questionable Negative Transition Register. It is a decimal value which corresponds to the binary-weighted sum of all bits set in the register. Setting a bit in the negative transition filter shall cause a 1 to 0 transition in the corresponding bit of the associated condition register to cause a 1 to be written in the associated bit of the corresponding event register.

Parameters:

<DNPD> Questionable Negative Transition Register, Range 0... 32767

Remarks:

Overlapped command

Example:

STAT:QUES:NTR 2

STAT:QUES:NTR? Response: 2

:STATus:QUEStionable:PTRansition

Syntax:

:STATus:QUEStionable:PTRansition <DNPD>

:STATus:QUEStionable:PTRansition?

Description:

This command allows set Questionable Positive Transition Register. It is a decimal value which corresponds to the binary-weighted sum of all bits set in the register. Setting a bit in the positive transition filter shall cause a 0 to 1 transition in the corresponding bit of the associated condition register to cause a 1 to be written in the associated bit of the corresponding event register.

Parameters:

<DNPD> Questionable Positive Transition Register, Range 0... 32767

Remarks:

Overlapped command

Example:

STAT:QUES:PTR 2

STAT:QUES:PTR? Response: 2

:SYSTem:BEEPer:STATe

Syntax:

```
:SYSTem:BEEPer:STATe <BOOL>
:SYSTem:BEEPer:STATe?
```

Description:

This command sets state of device beeper.

Parameters:

<BOOL>	{ ON OFF 1 0 } (default 1)
·ON	device system beeper is enabled
·OFF	device system beeper is disabled
·1	same as ON
·0	same as OFF

Remarks:

Overlapped command

Value is not affected by reset or by *RST command

Example:

```
SYST:BEEP:STAT ON
SYST:BEEP:STAT? Response: 1
```

:SYSTem:BEEPer:VOLume

Syntax:

```
:SYSTem:BEEPer:VOLume <DNPD>
:SYSTem:BEEPer:VOLume?
```

Description:

This command sets the system device beeper volume.

Parameters:

<DNPD>	Range 0.0 ... 1.0 (Max. volume) (default 0.2)
--------	---

Remarks:

Overlapped command

Value is not affected by reset or by *RST command

Example:

```
SYST:BEEP:VOL 0.2
SYST:BEEP:VOL? Response: 2.000000E-01
```

:SYSTem:COMMunicate:BUS

Syntax:

```
:SYSTem:COMMunicate:BUS <CPD>
:SYSTem:COMMunicate:BUS?
```

Description:

This command selects communication interface.

Parameters:

<CPD>	{ SERial GPIB USB LAN } (default SER)
·SERial	RS232 interface
·GPIB	GPIB interface
·USB	USB interface
·LAN	LAN interface

Remarks:

Sequential command

Value is not affected by reset or by *RST command

Example:

```
SYST:COMM:BUS SER
SYST:COMM:BUS? Response: SER
```

:SYSTem:COMMunicate:GPIB:ADDRess

Syntax:

```
:SYSTem:COMMunicate:GPIB:ADDRess <DNPD>
:SYSTem:COMMunicate:GPIB:ADDRess?
```

Description:

This commands allows set communication GPIB address

Parameters:

```
<DNPD>          Range 1 ... 31 (default 2)
```

Remarks:

Overlapped command
Value is not affected by reset or by *RST command

Example:

```
SYST:COMM:GPIB:ADDR 2
SYST:COMM:GPIB:ADDR? Response: 2
```

:SYSTem:COMMunicate:LAN:ADDRess

Syntax:

```
:SYSTem:COMMunicate:LAN:ADDRess <CPD>
:SYSTem:COMMunicate:LAN:ADDRess?
```

Description:

This command allows to change IP address if DHCP is switched off. Interface must be restarted to take effect (see SYST:COMM:REST command).

Parameters:

```
<CPD>          Range 000.000.000.000 ... 255.255.255.255 (default
192.168.001.100)
```

Remarks:

Overlapped command
Value is not affected by reset or by *RST command

Example:

```
SYST:COMM:LAN:ADDR 192.168.001.100
SYST:COMM:LAN:ADDR? Response: 192.168.001.100
```

:SYSTem:COMMunicate:LAN:MASK

Syntax:

```
:SYSTem:COMMunicate:LAN:MASK <CPD>
:SYSTem:COMMunicate:LAN:MASK?
```

Description:

This command allows to change subnet mask if DHCP is switched off. Interface must be restarted to take effect (see SYST:COMM:REST command).

Parameters:

```
<CPD>          Range 000.000.000.000 ... 255.255.255.255 (default
255.255.255.000)
```

Remarks:

Overlapped command
Value is not affected by reset or by *RST command

Example:

```
SYST:COMM:LAN:MASK 255.255.255.000
SYST:COMM:LAN:MASK? Response: 255.255.255.000
```

:SYSTem:COMMunicate:LAN:GATE

Syntax:

```
:SYSTem:COMMunicate:LAN:GATE <CPD>  
:SYSTem:COMMunicate:LAN:GATE?
```

Description:

This command allows to change default gateway if DHCP is switched off. Interface must be restarted to take effect (see SYST:COMM:REST command).

Parameters:

<CPD> Range 000.000.000.000 ... 255.255.255.255 (default 255.255.255.255)

Remarks:

Overlapped command
Value is not affected by reset or by *RST command

Example:

```
SYST:COMM:LAN:GATE 255.255.255.255  
SYST:COMM:LAN:GATE? Response: 255.255.255.255
```

:SYSTem:COMMunicate:LAN:PORT

Syntax:

```
:SYSTem:COMMunicate:LAN:PORT <DNPD>  
:SYSTem:COMMunicate:LAN:PORT?
```

Description:

This command allows to change port number. Interface must be restarted to take effect (see SYST:COMM:REST command).

Parameters:

<DNPD> Range 0 ... 9999 (default 23)

Remarks:

Overlapped command
Value is not affected by reset or by *RST command

Example:

```
SYST:COMM:LAN:PORT 23  
SYST:COMM:LAN:PORT? Response: 23
```

:SYSTem:COMMunicate:LAN:HOST

Syntax:

```
:SYSTem:COMMunicate:LAN:HOST <CPD>  
:SYSTem:COMMunicate:LAN:HOST?
```

Description:

This command allows to change host name if DHCP is switched on. Interface must be restarted to take effect (see SYST:COMM:REST command).

Parameters:

<CPD> Upper alpha, lower alpha, digits, underscores and spaces are allowable. Maximum string size is 14 characters.

Remarks:

Overlapped command
Value is not affected by reset or by *RST command

Example:

```
SYST:COMM:LAN:HOST M641_SNXXXXXX  
SYST:COMM:LAN:HOST? Response: M641_SNXXXXXX
```

:SYSTem:COMMunicate:LAN:DHCP

Syntax:

```
:SYSTem:COMMunicate:LAN:DHCP <BOOL>
:SYSTem:COMMunicate:LAN:DHCP?
```

Description:

This command allows switch On/Off DHCP.

Parameters:

<BOOL>	{ ON OFF 1 0} (default 1)
·ON	DHCP is On
·OFF	DHCP is Off
·1	same as ON
·0	same as OFF

Remarks:

Overlapped command

Value is not affected by reset or by *RST command

Example:

```
SYST:COMM:LAN:DHCP ON
SYST:COMM:LAN:DHCP? Response: 1
```

:SYSTem:COMMunicate:REStart

Syntax:

```
:SYSTem:COMMunicate:REStart
```

Description:

This command will restart communication interface. It will take several seconds. During this period device will not respond to any commands. Restart is needed for all LAN setting changes.

Parameters:

None

Remarks:

Overlapped command

Example:

```
SYST:COMM:REST
```

:SYSTem:COMMunicate:SERial:BAUD

Syntax:

```
:SYSTem:COMMunicate:SERial:BAUD <CPD>
:SYSTem:COMMunicate:SERial:BAUD?
```

Description:

This command allows changing RS232 transfer rate.

Parameters:

<CPD>	{ 1200 2400 4800 9600 19200 38400 57600 115200} (default 9600)
·1200	1200 Bd
·2400	2400 Bd
·4800	4800 Bd
·9600	9600 Bd
·19200	19200 Bd
·38400	38400 Bd
·57600	57600 Bd
·115200	115200 Bd

Remarks:

Overlapped command

Value is not affected by reset or by *RST command

Example:

```
SYST:COMM:SER:BAUD 9600
SYST:COMM:SER:BAUD? Response: 9600
```

:SYSTem:DATE

Syntax:

:SYSTem:DATE <DNPd>,<DNPd>,<DNPd>
:SYSTem:DATE?

Description:

This command allows to change system device date.

Parameters:

<DNPd> Year, Range 2000 ... 2063
<DNPd> Month, Range 1 ... 12
<DNPd> Day, Range 1 ... 31

Remarks:

Overlapped command

Example:

SYST:DATE 2012,12,31
SYST:DATE? Response: 2012,12,31

:SYSTem:ERRor[:NEXT]?

Syntax:

:SYSTem:ERRor[:NEXT]?

Description:

This command reads SCPI error (maximum 32) that occurred at first. If number of SCPI errors exceed 32, error -350 "Queue overflow" is returned. For all available error codes and messages see "SCPI Error codes" table. Error queue is cleared by reading all errors or by issuing *CLS command.

Parameters:

<DNPd> Error code
<SPd> Quoted error message

Remarks:

Overlapped command

Example:

SYST:ERR? Response: -300,"Device error"

:SYSTem:KEY

Syntax:

:SYSTem:KEY <DNPD>

:SYSTem:KEY?

Description:

This command allows send key code to the device the same way the user can press keys on front panel. Query returns last pressed key.

Key	Code
KEY_0	12
KEY_1	11
KEY_2	15
KEY_3	19
KEY_4	10
KEY_5	14
KEY_6	18
KEY_7	9
KEY_8	13
KEY_9	17
KEY_SELECT	25
KEY_ENTER	24
KEY_CANCEL	23
KEY_UP	2
KEY_DOWN	1
KEY_LEFT	3
KEY_RIGHT	4
KEY_EXPONENT	21
KEY_BACKSPACE	22
KEY_POINT	16
KEY_USER_1	5
KEY_USER_2	6
KEY_USER_3	7
KEY_USER_4	8
KEY_SIGN	20
KEY_OPER	26
KEY_SHORT	27

Table 5 Keyboard codes

Parameters:

<DNPD> Key code. For particular key codes see table above.

Remarks:

Overlapped command

Example:

SYST:KEY 12

SYST:KEY? Response: 12

:SYSTem:LOCAl

Syntax:

:SYSTem:LOCAl

Description:

This command places device in the LOCAL mode and unlocks all keys on front panel of the device. The Command is valid only for RS232, LAN and USB interfaces. The device will not respond to commands in LOCAL mode.

Parameters:

None

Remarks:

Overlapped command

Example:

SYST:LOC

:SYSTem:PRESet

Syntax:

:SYSTem:PRESet

Description:

This command will set all device (functions) parameters to default. The same as *RST without an actual restart.

Parameters:

None

Remarks:

Overlapped command

Example:

SYST:PRES

:SYSTem:REMOte

Syntax:

:SYSTem:REMOte

Description:

This command places device in the REMOTE mode and locks all keys but LOCAL key. The Command is valid only for RS232, LAN and USB interfaces. The device will not respond to any other command until is in REMOTE mode.

Parameters:

None

Remarks:

Overlapped command

Example:

SYST:REM

:SYSTem:RWLock

Syntax:

:SYSTem:RWLock

Description:

This command places device in the REMOTE mode and locks all keys including LOCAL key. The Command is valid only for RS232, LAN, USB interfaces. The device will not respond to any other command until is in REMOTE mode.

Parameters:

None

Remarks:

Overlapped command

Example:

SYST:RWL

:SYSTem:TIME

Syntax:

```
:SYSTem:TIME <DNPD>,<DNPD>,<DNPD>
:SYSTem:TIME?
```

Description:

This commands allows set system device time (RTC).

Parameters:

```
<DNPD>      Hours, Range 0 ... 23
<DNPD>      Minutes, Range 0 ... 59
<DNPD>      Seconds, Range 0 ... 59
```

Remarks:

Overlapped command

Example:

```
SYST:TIME 10,45,15
SYST:TIME? Response: 10,45,15
```

:SYSTem:VERSion?

Syntax:

```
:SYSTem:VERSion?
```

Description:

This query retrieves version of implemented SCPI language

Parameters:

```
<CPD>      SCPI language version
```

Remarks:

Overlapped command

Example:

```
SYST:VERS? Response: 1999.0
```

:UNIT:TEMPerature

Syntax:

```
:UNIT:TEMPerature <CPD>
:UNIT:TEMPerature?
```

Description:

This function allows to set unit for all temperature functions (Platinum, Nickel).

Parameters:

```
<CPD>      {CEL|FAR|K} (default CEL)
  ·CEL      degrees of Celsius
  ·FAR      degrees of Fahrenheit
  ·K        Kelvin
```

Remarks:

Overlapped command

Value is set according to “Startup” preset on restart and to default on *RST command

Example:

```
UNIT:TEMP CEL
UNIT:TEMP? Response: CEL
```

6.10. SCPI Error codes

RTD simulator distinguishes following SCPI error codes. These codes are reported on device display screen or can be read by SYST:ERR? Command.

Error	Message
-100	"Command error"
-101	"Invalid character"
-102	"Syntax error"
-103	"Invalid separator"
-104	"Data type error"
-105	"GET not allowed"
-108	"Parameter not allowed"
-109	"Missing parameter"
-112	"Program mnemonic too long"
-113	"Undefined header"
-114	"Header suffix out of range"
-120	"Numeric data error"
-121	"Invalid character in number"
-130	"Suffix error"
-141	"Invalid character data"
-144	"Character data too long"
-151	"Invalid string data"
-161	"Invalid block data"
-203	"Command protected"
-220	"Parameter error"
-222	"Data out of range"
-283	"Illegal variable name"
-350	"Queue overflow"
-400	"Query error"
-410	"Query INTERRUPTED"
-420	"Query UNTERMINATED"
-430	"Query DEADLOCKED"
-440	"Query UNTERMINATED after indefinite response"
514	"Command not allowed with GPIB"

Table 6 SCPI error codes

6.11. Compatible Commands

RTD simulator also responds to “Old style” command syntax to provide compatibility with previous decade box models.

Value setting / reading

A (?) <DNPD>

The command sets resistance value (resistance function) or temperature value (temperature sensor simulating function).

<DNPD>

Represents resistance value in Ohm or simulated temperature in selected temperature unit. When temperature parameter is used, both negative and positive values are acceptable. For resistance parameter positive value only is acceptable. Limit values are shown in chapter “Technical data”.

In case of control, the simulator confirms correct setting with string „Ok<cr><lf>”.

In case of query, M641 returns set resistance/temperature value in the same format as it is on the display (number of decimal places). For example value -120 °C is returned as -120.000<cr><lf>. Positive numbers are sent without polarity sign.

Example:

Command „A123.564 <cr>” sets temperature 123.564 °C when in temperature function, 123.564 Ω when in resistance function.

On „A?<cr>” query simulator returns response in format „123.564<cr><lf>”.

RTD simulator function setting

F <CPD> { 0 | 1 | 2 | 3 | 4 | 5 | 6 | 7 | S | O }

Following function can be set:

- 0 resistance mode
- 1 Pt385 (68) temperature sensor simulation
- 2 Pt385 (90) temperature sensor simulation
- 3 Pt3916 temperature sensor simulation
- 4 Ni temperature sensor simulation
- 5 User platinum temperature sensor simulation
- 6 Pt3926 temperature sensor simulation
- 7 User function simulation
- S Short
- O Open

M641 confirms execution with string „Ok<cr><lf>”.

Example:

„F1<cr>” sets Pt100 sensor simulation.

I/D (device identification)***IDN?**

Response contains name of manufacturer, model type number, serial number, firmware version

Example:

If query „*IDN?<cr>” is sent, simulator returns response:

„MEATEST,M641,622351,1.2 <cr><lf>“.

R0 setting / reading**R (?) <DNPD>**

Command sets resistance value R0 at temperature 0 °C. Set value R0 is valid for all types of simulated temperature sensors.

<DNPD>

It represents resistance value R0 in Ω . Limits are shown in chapter Technical data. M641 confirms execution with string „Ok<cr><lf>”. In case of query M641 returns set value in Ω .

Example:

„R100<cr>” sets value R0 to 100 Ω (Pt100, Ni100).

After query „R?<cr>” simulator returns string „100<cr><lf>”.

Temperature unit setting**U <CPD> { 0 | 1 | 2 }**

Command sets used temperature unit.

- 0 sets degree Celsius °C
- 1 sets degree Fahrenheit °F
- 2 sets Kelvin unit K

M641 confirms execution with string „Ok<cr><lf>”.

Example:

„U0<cr>” sets °C as temperature unit.

Status reading**V?**

M641 returns device status in form „FxUx<cr><lf>“. On positions of signs „x“ there are values corresponding to the actual status of the simulator.

Example:

After query „V?<cr>” the simulator returns for example string „F2U0<cr><lf>”, which means Pt (90), °C actual setting.

Correctly executed command is confirmed with string "Ok<cr><lf>. When correct query is received M641 returns response in above described format. All commands must contain sign <cr> or <lf> at the end. Both small and large letters can be used.

6.12. Demo program

A simple operating program DecadeAssistant is supplied with the simulator in order to provide easy operation of the instrument from the computer, and to check the RS-232 line (IEEE488 bus) of the instrument. The installation CD ROM contains a program (for MS WINDOWS only), you can communicate with the instrument through standard serial line (IEEE488) with. For example, you can set value or function on the simulator. For IEEE488 connection this DecadeAssistant requires properly configured National Instruments IEEE488 card.

Download on www.meatest.com.

7. Maintenance

This chapter explains how to perform the routine maintenance to keep your device in optimal operating condition. The tasks covered in this chapter include the following:

- Fuse replacing
- External surface cleaning

7.1. Fuse replacing

The instrument includes a fuse located in the mains connector at the rear panel. Replace the fuse as follows:

- Switch off the simulator
- Remove the end of power cord from the mains connector at the rear panel.
- Insert the blade of a flat screwdriver into the opening cut in the mains voltage selector and pull out the fuse holder.
- Remove the fuse and replace it with new fuse of the same rating.

7.2. External surface cleaning

To keep the device looking like new, clean the case and front panel keys using a soft cloth slightly dampened with either water or a non-abrasive mild cleaning solution that is not harmful to plastics.

8. Module 19" (version M641-Vxx1x)

RTD Simulator can be ordered as 19" module for easy assembling into a 19" rack. Module height is 3HE.



Figure 30 Module 19" rack, front panel

9. Technical data

Resistance range	:	10 Ω ... 300 k Ω SHORT, OPEN terminals
Pt sensor temperature simulation	:	-200.000 $^{\circ}\text{C}$... 850.000 $^{\circ}\text{C}$ (-328 $^{\circ}\text{F}$... 1562 $^{\circ}\text{F}$)
Ni sensor temperature simulation	:	-60.000 $^{\circ}\text{C}$... 300.000 $^{\circ}\text{C}$ (-76 $^{\circ}\text{F}$... 572 $^{\circ}\text{F}$)
Type of temperature sensors	:	Pt100 ... Pt1000, Ni100 ... Ni1000
Resolution	:	from 0.1 m Ω
Pt temperature standards	:	IEC 751 (1,3850 for IPTS68) (A=3.90802e-3, B=-5.80195e-7, C=-4.2735e-12) IEC 751 (1,3851 for ITS90) (A=3.9083e-3, B=-5.775e-7, C=-4.18301e-12) 1,3916 (A=3.9692e-3, B=-5.8495e-7, C=-4.2325e-12) 1,3926 (A=3.9848e-3, B=-5.870e-7, C=-4.0e-12)
Ni temperature standards	:	DIN 43760 (6180) (A=5.485e-3, B=6.65e-6, C=2.805e-11, D=-2e-17)
Maximal dissipation power	:	5 W
Maximal current	:	0.5 A
Maximal voltage	:	200 Vpk
Reaction time *	:	6 ms
Terminals	:	instrument terminals diameter 4mm, gold plated
Interface	:	RS232 (optionally IEEE488, USB, Ethernet)
Power supply	:	115/230 Vac, 45...65 Hz
Maximal power consumption	:	15 VA
Reference temperature	:	+20 $^{\circ}\text{C}$... +26 $^{\circ}\text{C}$
Working temperature	:	+5 $^{\circ}\text{C}$... +40 $^{\circ}\text{C}$
Storing temperature	:	-10 $^{\circ}\text{C}$... +50 $^{\circ}\text{C}$
Housing	:	metal sheet
Dimensions	:	W 390 mm, H 128 mm, D 310 mm
Weight	:	4 kg

Isolation resistance between output terminals and housing : > 2 G Ω (at 500V DC)

* *Reaction time means time interval between setting up value from front panel or receiving command from remote control bus and settling set-up value on output terminals. Value is valid for FAST switching mode.*

Notes:

Only data shown with tolerance or with band of limits are tested. All other values have informative character.

Accuracy

Specified accuracy is valid after 10 minutes warm up in temperature range $23 \pm 3^\circ\text{C}$ and for the power load less than 1W. Uncertainties include long-term stability, temperature coefficient, linearity, load and line regulation and traceability of factory to National calibration standards. Accuracies assigned in % are related to the set value. Specified accuracy is one-year accuracy.

M641 Resistance accuracy

Range / Resolution	Accuracy
10.0000 Ω - 20.0000 Ω	0.05 % + 15 m Ω
20.001 Ω - 200.000 Ω	0.05 % + 15 m Ω
200.01 Ω - 1000.00 Ω	0.02 %
1.0001 k Ω - 3.0000 k Ω	0.02 %
3.001 k Ω - 10.000 k Ω	0.02 %
10.01 k Ω - 30.00 k Ω	0.05 %
30.1 k Ω - 100.0 k Ω	0.1 %
101 k Ω - 300 k Ω	0.5 %

Table 7 M641 Resistance accuracy

M641 Pt simulation accuracy

Temperature range	Pt100-Pt1000
-200.000...0.000 $^\circ\text{C}$	0.15 $^\circ\text{C}$
0.001...850.000 $^\circ\text{C}$	0.2 $^\circ\text{C}$

Table 8 M641 Pt simulation accuracy

M641 Ni simulation accuracy

Temperature range	Ni100-Ni1000
-60.000...300.00 $^\circ\text{C}$	0.1 $^\circ\text{C}$

Table 9 M641 Ni simulation accuracy

M641 Frequency response

R	Max. AC/DC difference		
	100 Hz	1 kHz	10 kHz
10 Ω	0.01 %	0.01 %	0.05 %
100 Ω	0.01 %	0.05 %	0.50 %
1 k Ω	0.04 %	0.40 %	4.00 %
10 k Ω	0.40 %	4.00 %	
100 k Ω	4.00 %		

Table 10 M641 Frequency response

Temperature coefficient

Temperature coefficient outside of the reference temperature range is 10 % of the stated specification per $^\circ\text{C}$ (for example 2x specification for 36°C).

Power coefficient

Power coefficient above 1W is 50 % of the stated specification per W (for example 3x specification for 5W load).

Short and Open simulation

„SHORT“ resistance is lower than 40 m Ω . Maximal allowed current is 500 mA.

„OPEN“ resistance is higher than 10 G Ω . Maximal allowed voltage is 200 Vpk.

Note: Resistance values in range 10 Ω - 300 k Ω are calibrated absolutely. Resistance value is not defined against SHORT position. Short and Open positions are intended for functional checking of tested instrument only.

10. Ordering information – options

Bus

M641-V1xxx - RS232

M641-V2xxx - RS232, LAN, USB, IEEE488

Housing

M641-Vxx0x - table version

M641-Vxx1x - module 19“, 3HE

Example of order:

M641-V2010

- Programmable RTD Simulator 10Ω - 300kΩ, RS232, LAN, USB, IEEE488, 19“ rack

Manufacturer

MEATEST, s.r.o.

Železná 509/3, 619 00 Brno

Czech Republic

www.meatest.com

tel: +420 543 250 886

fax: +420 543 250 890

meatest@meatest.cz