

M – 142

Multifunction Calibrator

Operation Manual



Content

Operation Manual	1
List of tables	5
Basic Information	6
Preparation for operation	7
Inspecting package contents, selecting the installation location	7
Power-on	7
Warm-up time	7
Replacement of fuse	8
Storing	8
Safety precautions	8
Description of controls	9
Front panel	9
Rear panel	15
Control of the calibrator	16
Selection of function	16
Setting the value of output signal	16
Setting relative deviation	18
Change of value by factor of ten	19
Connection / disconnection of output terminals	19
Setting the frequency	20
Generation of calibrated voltage	21
Generation of calibrated current	23
Generation of non-harmonic shapes	24
Simulation of resistance and capacitance	25
Generation of electric power and energy	27
Generation of frequency	32
Simulation of temperature sensors	35
Multimeter	39
Basic menu	39
Function selection	40
Setting the measurement range	40
Units of measurement	41
Use of calculation formula	42
Setting function parameters	42

Start of measurement	43
Zero function	43
Simultaneous functions	45
Setup menu	46
Calibration mode	50
Error messages	68
Functional description of the calibrator	70
Calibrator's maintenance	76
Verification test	78
System control	86
IEEE-488 bus properties	86
RS232 bus properties	86
Command syntax	87
Standard Status Data Structures	101
Examples of use	104
Calibration of measuring instruments	104
Multimeters	104
Powermeters	106
Counters and oscilloscopes	108
Thermometers	108
Measurement using the calibrator	109
Voltage, current and frequency	109
Measurement of resistance or temperature using resistance temperature sensors	109
Measurement of temperature using thermocouples	110
Testing of control unit, transducers and evaluation units	110
Option 40/60 cable adapter application	110
Option 70 application	110
Option 80 application	111
Option 90 application	111
Examples of tests	112
Specification	113
Accessories	120
Operation Manual Supplement	122
Change 1	122
Change 2	122
Change 3	122

List of tables

Tab. 1	Functions	8
Tab. 2	Reference values	8
Tab. 3	Auxiliary connector description	10
Tab. 4	Display buttons description	12
Tab. 5	Cable adapters description	43
Tab.6	DC VOLTAGE calibration points	53
Tab.7	AC VOLTAGE calibration points	53
Tab.8	DC CURRENT calibration points	54
Tab.9	AC CURRENT calibration points	54
Tab.10	DC POWER calibration points	55
Tab.11	AC POWER calibration points	55
Tab.12	R calibration points	56
Tab.13	C calibration points	57
Tab.14	F calibration points	57
Tab.15	Multimeter calibration points	57
Tab. 16	Error messages	67
Tab. 17	RS232 connector description	84
Tab. 18	Recommended way of signal terminal grounding	105
Tab. 19	Application of cable adapters	107
Tab.20	Overview of cable adapters	109
Table I	Verification test VDC 20V	80
Table II	Verification test VDC	80
Table III	Verification test VAC 20V	80
Table IV	Verification test VAC	81
Table V	Verification test ADC 200mA	81
Table VI	Verification test ADC	81
Table VII	Verification test AAC	82
Table VIII	Verification test AACDC High current	82
Table IX	Verification test ACDC Power	82
Table X	Verification test R	82
Table XI	Verification test C	82
Table XII	Verification test F	83
Table XIII	Verification test Multimeter	83

Basic Information

M-142 Multifunction Calibrator is a multifunction calibrator, to be used primarily as a standard for calibration laboratories. It can be used for calibration of any measuring instrument which measures voltage, current, resistance, capacitance and frequency. It generates fixed non-harmonic signals to allow calibration of measuring instruments using signals with non-zero harmonic distortion. Frequency, amplitude and duty cycle of output signal can be adjusted. M-142 Multifunction Calibrator is also suitable for basic calibration of oscilloscopes.

The calibrator includes a function which simulates resistance and thermocouple temperature sensors and a built-in multimeter, which can be used simultaneously. Transducers of various types, regulators and sensing units can be therefore checked without the need for additional measuring instruments.

Basic features of the calibrator include generation of calibrated DC and AC voltage in the range of 0 μ V to 1000 V, DC and AC current in the range of 0 μ A to 30 A (50 μ A to 1000 A when using a 50-turn coil). The best accuracy of the calibrator is 0.0015 % for DC voltage. Maximum frequency range is 20 Hz to 100 kHz. The calibrator can generate periodic non-harmonic signal with defined duty cycle. This facilitates especially the checks of multimeters and their accuracy when measuring non-harmonic DC signals.

The calibrator can also simulate a resistance or capacitance. Resistance range is 0 Ω to 1000 M Ω ; capacitance range is 1 nF to 100 μ F, the accuracy suits the calibration of common multimeters. Basic accuracy of resistance ranges is 0.015 %. Basic accuracy of capacitance ranges is 0.5 %.

Frequency ranges of the calibrator can generate a squarewave signal with definable and calibrated duty cycle and amplitude in the 1 mV to 200 V range and 0 to 10 kHz frequency range. Moreover, squarewave signal with very steep rising edge can be generated up to 20 MHz. Frequency ranges can be used to calibrate the corresponding frequency ranges of multimeters, as well as to calibrate the input sensitivity and time bases of oscilloscopes.

Powermeter mode can be used to calibrate DC and AC single phase powermeters and energy meters. Voltage range is up to 240 V and current range is up to 20 A, power factor range is -1 to +1 and the resolution is 1 % in the 40 Hz to 400 Hz frequency range. The voltage output can supply loads up to 30 mA, which allows the calibration of mechanical powermeters.

Simulation of temperature sensors is yet another feature which can be used to calibrate thermometers and heat sensing units. The calibrator allows the simulation of all common Pt and Ni resistance sensors and R, S, B, J, T, E, K, N type thermocouples. Compensation of cold junction of thermocouple is achieved by entering the respective temperature using the calibrator's keyboard. The accuracy of simulated temperature sensors depends on the value and type of sensor and ranges from 0.04 $^{\circ}$ C to 0.5 $^{\circ}$ C for resistance sensors and from 0.4 $^{\circ}$ C to 4.3 $^{\circ}$ C for thermocouples.

Internal multimeter with 20 mA, 20 mV, 200 mV and 10 V basic ranges and 0.01 % accuracy can be used to measure normalized signals coming from transducers, external thermocouples or resistance sensors or to measure pressure and force using strain gauge sensors.

The calibrator includes many other features which facilitate easy use. For example relative deviation from set value of the output, currently displayed uncertainty of the output signal, calibration and testing procedures etc. The concept of calibrator control and indication of its status is based on flat luminiscent display, which provides all necessary information. The calibrator is controlled by opening menus on the display and selection from menus. Frequently used functions are assigned direct-control keys. The calibrator comes with standard GPIB bus and RS-232 serial line, which allow the calibrator to be controlled from a PC.

The calibrator can easily fit within calibration systems featuring WinQbase/CALIBER software support.

ATTENTION !

The calibrator generates life-threatening high voltage.

The calibrator can only be used in line with this manual.

Preparation for operation

Inspecting package contents, selecting the installation location

Basic package includes the following items:

- Multifunction calibrator
- Power cord
- Spare fuse T4L250/T, T8L250/T
- Operation manual.
- Test report
- Test cable 1000V/20 A 2 pcs
- Cable adapter Option 40
- Cable adapter Option 60
- Cable adapter Option 70
- Cable adapter Option 80
- RS 232 cable

The calibrator should be powered by 230/115 V – 50/60 Hz mains. It is a laboratory instrument whose parameters are guaranteed at 23 ± 2 °C. Before powering on the instruments, place it on a level surface. Do not cover the vents at the bottom side and the fan opening at the rear panel. Leave the calibrator to stabilize to ambient temperature and humidity at minimum 4 hours after unpacking.

If you need to reship the Calibrator, use the original container. If it is not available, you can order a new container from manufacturer by identifying the Calibrator's model and serial number.

Power-on

- Before connecting the calibrator to the mains, check the position of the mains voltage selector located at the rear panel.
- Plug one end of the power cord into the connector located at the rear panel and connect the other end of the power cord into a wall outlet.
- Switch on the mains switch located at the rear panel. Flat display is lit.
- The calibrator performs internal hardware checks for 5 seconds.
- After the tests conclude, the calibrator resets to its reference state, i.e. the following parameters are set:

Function	DC voltage
Range	20 V
Set value	10 V
Output terminals	OFF

GPIB address of the calibrator is factory-preset to 2. This value is valid until the user changes it.

Note. The calibrator resets to its reference status in case of power switching off and reconnection.

Warm-up time

The calibrator works after it is switched on and the initial checks complete. Specified parameters are only guaranteed after the instrument warms up for 60 minutes. During this period, the instrument cannot be calibrated. The display shows “cannot access the calibration” message if calibration is attempted during this period.

Replacement of fuse

The calibrator includes a fuse located in the mains connector at the rear panel. Replace the fuse as follows:

- Switch off the calibrator
- Remove the end of power cord from the mains connector at the rear panel.
- Insert the blade of a flat screwdriver into the opening cut in the mains voltage selector and pull out the fuse holder.
- Remove the fuse and replace it with new fuse of the same rating.

Storing

The calibrator can be stored in original packing under storing conditions specified in chapter Specification.

Safety precautions

The instrument has been designed in Safety Class I according to EN 61010-1. The design reflects the requirements of A2 amendment of the standard.

Safety is ensured by the design and by the use of specific component types.

The manufacturer is not liable for the damage caused by modification of the construction or replacement of parts with non-original ones.

Safety symbols used on the equipment



Warning, reference to the documentation

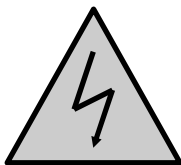

Warning - risk of electric shock



Danger - high voltage

Description of controls

Front panel

The front panel of the calibrator includes a flat luminiscent display, control buttons and output terminals. The following picture shows the control part of the front panel.

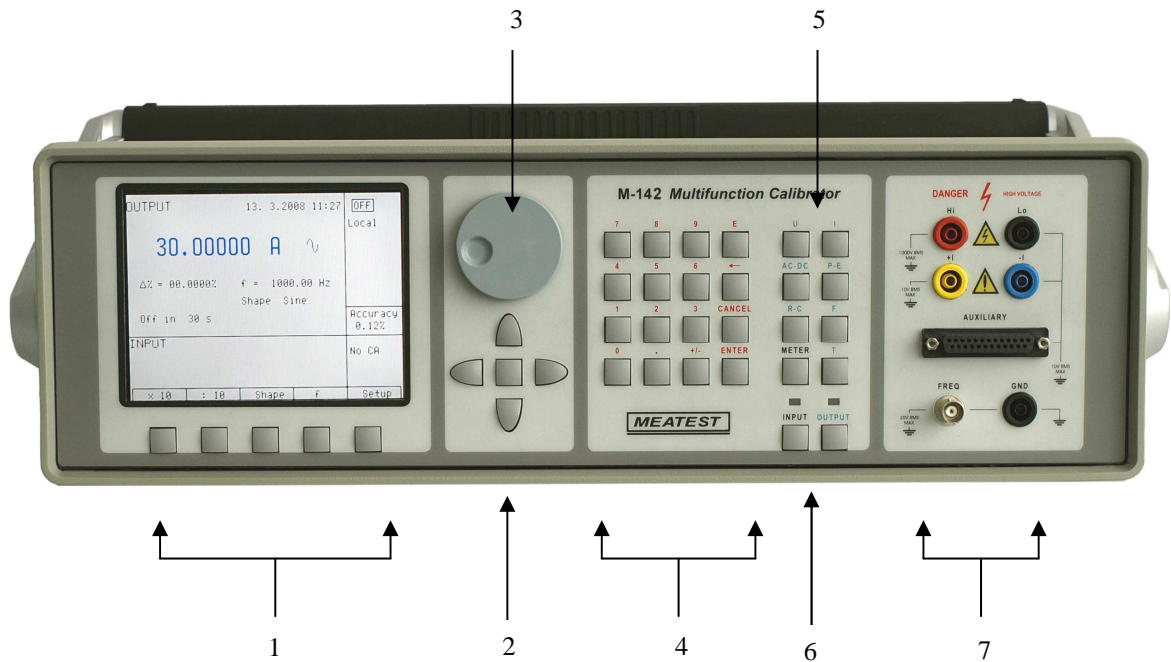

1 Display buttons

There are five buttons below the display, whose meaning changes depending on the contents of the display. These buttons usually call-up the MENU, allow range change, step, logging of values etc.

2 Cursor buttons

Using these buttons, the cursor can be controlled within allowed limits on the display. The keyboard includes two buttons (<, >) which allow the cursor to be set to the required position at the display. The cursor can be moved to the left or right. These buttons are usually used to step through the options and to move from one option to another or between the menu levels. Numeric values can be set in some control modes as well. In these cases, the buttons marked (\wedge , \vee) allow the user to increase or decrease the number at the cursor button.

The central button is used to confirm the selection (ENTER), or to SELECT from the menu.

3 Potentiometer

The potentiometer integrates several functions. By turning the knob to the left or right, the user can:

- step through the options
- enter numeric values

The function of the potentiometer can usually be performed by the cursor buttons. The central button is used to confirm the selection (ENTER).

4 Numeric keyboard

The keyboard allows the entry of numeric values on the display. The central button is used to confirm the selection (ENTER). CANCEL button can be used to cancel the entry.

5 Function buttons

Function buttons can be used to call-up the functions of the calibrator directly. The following buttons are provided:

<i>function</i>	<i>button</i>
DC voltage	U / DC
AC voltage	U / AC
DC current	I / DC
AC current	I / AC
resistance / capacitance	R – C
power / energy	P – E
frequency	F
internal multimeter	METER
simulation of temperature sensors	T

Tab. I One touch buttons

After the function mode is changed, the parameters of the respective function are restored. If the respective function was never used, the calibrator resets to its reference values. Reference values for individual functions are listed below.

<i>function</i>	<i>value</i>	<i>parameters</i>
DC voltage	10V	--
AC voltage	10 V	f = 1000 Hz
DC current	100 mA	--
AC current	100 mA	f = 1000 Hz
resistance	100 k Ω	
capacitance	1 μ F	
power	100 W	f = 100 Hz ^{*1}
energy		
frequency	1000 Hz	U = 1 V _{sym}
multimeter	10 V	DC voltage
simulation of temperature sensors	100 °C	Pt 100/1.385, ITS90
cold junction temperature of TC sensors	23 °C	R

Tab. 2 Reference values

^{*1} U = 100 V, I = 1 A, PF(power factor) = 1 LA, active power is displayed in Watts

6 Output / input terminals buttons

OUTPUT button is used to connect the output signal of the calibrator to the output terminals. The connection is confirmed by red LED and a symbol at the display.

METER button can be used to connect the input terminals to the internal multimeter. The connection is confirmed by green LED.

7 Output / input terminals

Output signal of the calibrator is connected to the output terminals. Current ranges are connected to **+I / -I** terminals, frequency output is connected to **FREQ** terminal. All other functions (voltage, resistance, capacitance) are connected to **Hi / Lo** terminals.

GND terminal is connected to the chassis of the calibrator. It is connected to the ground terminal of the mains plug. Using the SETUP MENU of the calibrator, the output terminals of the calibrator can be grounded as well. Grounding is done internally by connecting Lo and GND terminals using a relay. This circuit design is suitable for most calibrations, when the object (multimeter) being calibrated is floating.

AUXILIARY connector creates input of internal multimeter. It includes a limited range of output signals of the calibrator as well. The layout of individual pins and their meanings are listed in the following table.

Auxiliary connector can be used with one of cable adapters Opt. 40, 60, 70, 80, 90 Opt. 140-01. Calibrator can recognize which type of adapter is connected and displays the information on front panel display.

<i>pin</i>	<i>label</i>	<i>signal</i>	<i>Limitation</i>
1	0V5MER	common terminal of multimeter power supply source	
2	GND	ground (protection earth)	
3	SIMLI	RC simulator output, current terminal Li	U _{max.} = 10V _{pp} , I _{max.} =40mA
4	SIMLU	RC simulator output, voltage terminal Lu	U _{max.} = 10V _{pp} , I _{max.} =40mA
5	GND	ground (protection earth)	
6	L	common terminal of multimeter input	
7	-U	low output terminal for DC voltage range	
8	-I	low output terminal for DC current range	
9	NG2	sort function output, contact 2 of sort relay	U _{max.} =50V _{pp} , I _{max.} =100 mA
10	PTLI	resistance temperature sensor input terminal Li	U _{max.} = 10V _{pp} . R<2 kΩ
11	PTLU	resistance temperature sensor input terminal Lu input terminal L on ranges 20, 200, 2000 mV	U _{max.} = 10V _{pp} . R<2 kΩ
12	TEST1	identification terminal of actually used adapter	
13	TEST3	identification terminal of actually used adapter	
14	0V5MER	common terminal of multimeter power supply source	
15	NC	not used	
16	SIMHI	RC simulator output, current terminal Hi	U _{max.} = 10V _{pp} , I _{max.} =40mA
17	SIMHU	RC simulator output, voltage terminal Hu	U _{max.} = 10V _{pp} , I _{max.} =40mA
18	NC	not used	
19	INP	multimeter input terminal for voltage/current ranges	U _{max.} =25 V _{pp} , I _{max.} =25 mA
20	+U	high output terminal for DC voltage range	U _{max.} =20 V _{ss}
21	+I	high output terminal for DC current range	I _{max.} =25 mA
22	NG1	sort function output, contact 1 of relay	U _{max.} =50V _{pp} , I _{max.} =100 mA
23	PTHI	resistance temperature sensor input terminal Hi	U _{max.} = 10V _{pp} . R<2 kΩ
24	PTHU	resistance temperature sensor input terminal Hu input terminal H on ranges 20, 200, 2000 mV	U _{max.} = 10V _{pp} . R<2 kΩ
25	TEST2	identification terminal of actually used adapter	TEST1

Tab. 3 Auxiliary connector description

Functional inputs and outputs present at the connector can be best utilized using supplied cable adapters.

LCD display shows all information provided by the calibrator, e.g. set parameters of the signal, error messages, setup information. The display is divided to several information sections.

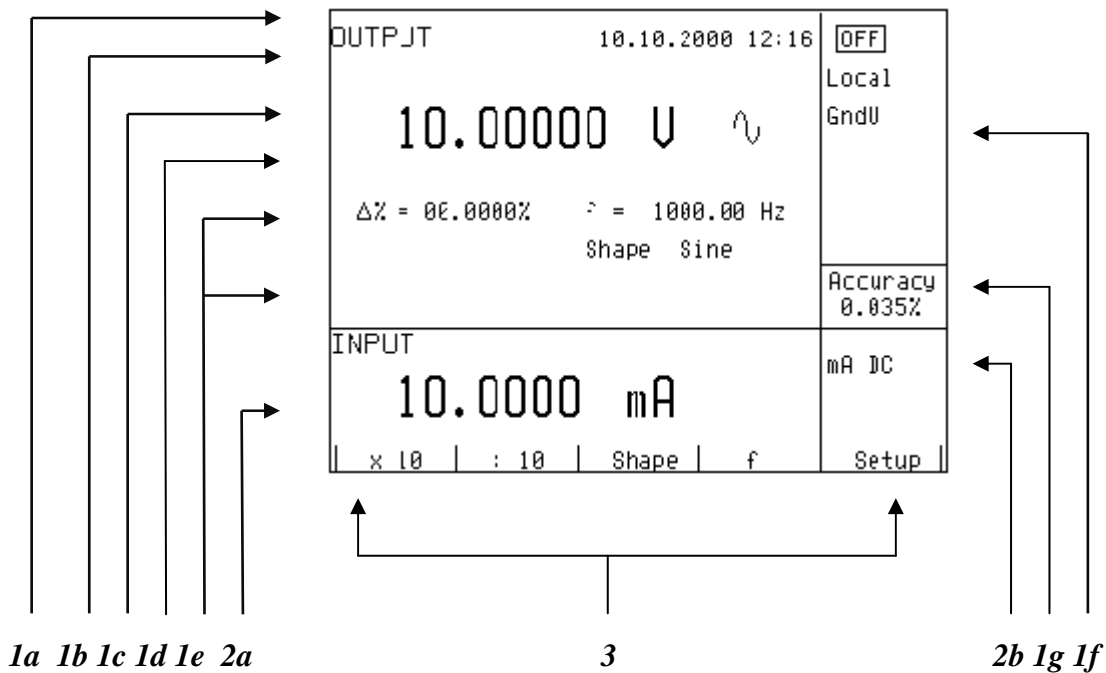
8 *Display*

The display is divided to three horizontal sections:

1. **OUTPUT section**

This section displays the set-up values of generated signals and the data related to the calibrator status. The section includes the following types of data:

a) *Information line*

- designation of display section: OUTPUT
- error messages. The messages appear when an attempt is made to set up an invalid state of the calibrator, if analogue circuits of the calibrator are overloaded or if a communication error occurs when the calibrator is controlled using GPIB bus.
- real date and time, if its display is set-up in the setup menu.

b) *Auxiliary data*

This line displays the total value of output signal if a non-zero relative deviation is set.

c) *Main data*

This line displays the main data of the output signal and the unit of measurement (using double size signs). The line also includes two symbols (▼▲) to define the actual position of the cursor during adjustment of the value. <, > buttons can be used to move the cursor and ^, v buttons to change the value. (The value can be also changed using the potentiometer).

d) *Monitoring line*

This line displays the numbers entered using the numeric keyboard when the main data are set using the numeric keyboard. The information allows the entered information to be checked.

e) *Minor data*

There are two lines displaying the minor data of the output signal, especially:

- set relative deviation from main set value in %
- frequency (for DC voltage, current, power, energy functions)

- set value of current, voltage or power factor (phase) for power, energy functions
- value of R0 resistance and the type of resistance temperature sensor
- cold junction temperature of TC sensors and the selected type of TC sensor
- value of amplitude and shape type for frequency function

f) *Information section*

The information section located in the right part of the display displays additional information related to the selected function:

- symbol of connected or disconnected output terminals.

At the same time, a LED located above the OUTPUT button is lit.

- information about remote/local control of the calibrator. If the calibrator is controlled remotely, REM is displayed. If the calibrator is controlled locally using the keyboard, LOCAL is displayed.
- information about the use of 50-turn coil (COIL x50) at the current output of the calibrator, if this feature is turned on using the SETUP menu.
- information about the type of connected cable adapter, if used
- information about the grounding method of output terminals: GND I, GND U as set up using the setup menu.

g) *Information about the uncertainty of the output signal*

This section displays the maximum error of the main value of the output signal. The value is calculated using the main specification listed in the User's Manual and it is displayed in %.

2. INPUT section

This section displays the values measured by the multimeter. The section includes following data:

a) *Main value of measured signal*

This line displays the measured value and the unit of measurement. If the input signals exceed the permitted range, OVERFLOW is displayed.

b) *Designation of selected function of the multimeter*

Symbolic display of selected function of the multimeter: V DC, mA DC, mV DC, R 4W, Freq, T TC, T RTD, ACAL.

3. Display buttons section

This line displays the symbolic descriptions which define the meaning of four related display buttons. The respective meanings are as follows:

<i>symbol</i>	<i>button function</i>	<i>note</i>
x 10	increase set value 10 x	
: 10	decrease set value 10 x	
Shape	selection of signal shape	only for U, I, F functions
+/-	reversed polarity of output voltage and current	only for DC U, DC I functions
EXIT	move up one level	only for F, P-E functions
Calib.	enter the calibration menu	
SETUP	enter the setup menu	
TC type	selection of thermocouple sensor type	only for T function
RTD type	selection of resistance temperature sensor type	only for T function
f	enter the frequency of the signal	only for U, I function
MODE	select the unit of measurement	only for AC P-E function

Tab. 4 Display buttons description

Rear panel

The rear panel of the calibrator includes ventilation holes, power cord socket with fuse, mains voltage selector, mains switch, IEEE 488 connectors for connection to GPIB bus and type plate with serial number.

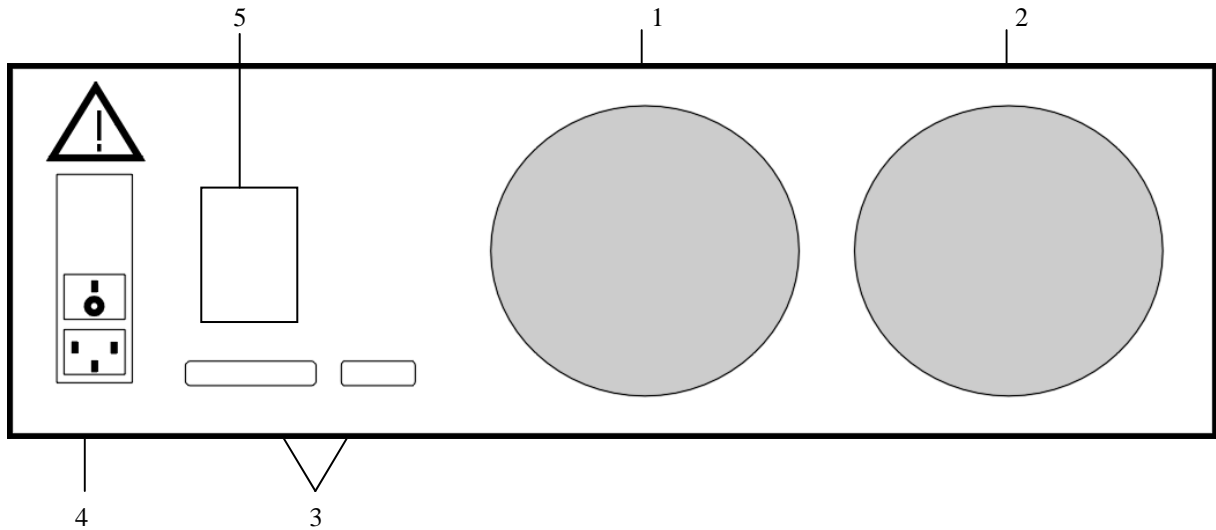

- 1 air inlet - forced ventilation
- 2 air outlet - forced ventilation
- 3 GPIB, RS-232 connectors
- 4 power cord socket with fuse, mains voltage selector, mains switch
- 5 type plate

Control of the calibrator

Selection of function

After the power is switched on and the initial checks complete, the calibrator resets to its reference status, i.e. DC voltage output with set value of 10 V and output terminals disconnected. Internal multimeter is switched off. The status of the calibrator can be changed using the buttons located at the front panel in one of the following ways:

1. *Change of function by pressing one of direct function buttons*

After pressing one of the U, I, DC-AC, R-C, P-E, F, T, METER buttons, the calibrator switches to the desired function mode and resets to the reference or to the most recently used parameter setting.

2. *Connection /disconnection of output terminals*

After pressing the OUTPUT button, the output terminals of the calibrator are connected/disconnected.

3. *Connection /disconnection of multimeter*

After pressing the INPUT button, the multimeter starts measuring the value present at the input terminals, depending on the function mode of the multimeter. The measurement is only possible when any of Opt. 140-xx adapters is connected to the AUXILIARY connector.

4. *Entry to the setup menu*

After pressing the SETUP button, options of the SETUP MENU appear on the display and the display buttons allow the entry to the calibration mode (CALIB). Previous function is restored by pressing of EXIT display button.

Setting the value of output signal

All function modes allow several methods of setting the main value of the output signal:

Entry of the value using numeric keyboard

- use the numeric keyboard to select the desired value. After the first digit is entered, symbols of unit of measurements are displayed above the display buttons. The monitor line displays the symbols [_ _ _ _ _].
- the same entry can be started by pressing the central cursor button
- after the entry is complete (the value is displayed on the monitor line), press the display button below the desired unit of measurement (V, mV or μ V in the example below)
- the value is copied to the main display and the monitor line disappears.

OUTPUT		10.10.2000 12:19	[OFF]
10.00000 U \sim			Local GndU
: 5.236-----]			
$\Delta\%$ = 00.0000%		f = 1000.00 Hz	
Shape Sine			Accuracy 0.035%
INPUT			ACAL
μ V	mV	V	Exit

Entry of the value using cursor buttons

- press <, >, ^ or v button. The display now includes cursor marks which point to the active digit.
- ^ and v buttons can be used to change the active digit. <, > buttons can be used to change the position of the cursor marks
- to get to the default screen, press EXIT button or keep pressing the center cursor button until there is no [_ _ _ _ _] under any value. All values can be set using the buttons or the potentiometer.

Entry of the value using the potentiometer

- press the potentiometer knob. The display now includes cursor marks which point to the active digit
- turn the knob to change the active digit
- press the potentiometer knob to change to the mode which allows to change the value of the active digit. ← and → symbols are displayed above the active digit. Active digit can be changed by turning the knob.
- turn the knob to change back to the mode which allows to change the position of the active digit.
- to get to the default screen, keep pressing the center cursor button until there is no [_ _ _ _ _] under any value, or press EXIT button. All values can be set using the buttons or the potentiometer.

Reverse polarity

In DC voltage and DC current modes, the polarity of the output value can be reversed by pressing +/- display button. „-“ symbol appears in front of the main data value.

Setting relative deviation

All function modes of the calibrator except frequency mode allow a relative deviation of output value from the main data to be set using a separate display. Relative deviation is displayed in the “minor data” section of the display and is designated with „ $\Delta\% = 00.0000\%$ ” symbol. The relative deviation can be entered using one of the methods described above, e.g. using the numeric keyboard, cursor keys or the potentiometer.

Setting relative deviation using numeric keyboard

- keep pressing the center cursor button until [_ _ _ _ _] symbols appear under the relative deviation value in the “minor data” section of the display
- enter the desired deviation and confirm the value by pressing “ % “ display button or by pressing ENTER on the numeric keyboard
- the auxiliary line below the main data on the display displays the total value of output signal including the unit of measurement
- the value of the signal at output terminals is: the value indicated by the main display + $\Delta\%$.

OUTPJT	10.10.2000 12:19	[OFF]
10.00000 U	~	Local GndU
$\Delta\% = 00.0000\%$ [0.15-----]	$f = 1000.00$ Hz Shape Sine	Accuracy 0.035%
INPUT		ACAL
%		Exit

Maximum relative deviation which can be entered is $\pm 30.000\%$.

The deviation can be positive or negative. If negative deviation is desired, press the display button labeled +/- . If positive deviation is then desired, press “ +/- “ button again. The polarity of the relative deviation can be reversed using the cursor buttons or the potentiometer as well.

Setting relative deviation using cursor keys

- keep pressing the center cursor button until [_ _ _ _ _] symbols appear under the relative deviation value
- press <, >, ^ or v button. The display now includes cursor marks which point to the active digit
- ^ and v buttons can be used to change the active digit. <, > buttons can be used to change the position of the cursor marks
- to get to the default screen, keep pressing the center cursor button until there is no [_ _ _ _ _] under any value, or press EXIT button. All values can be set using the buttons or the potentiometer..

Setting relative deviation using potentiometer

- keep pressing the center cursor button until [_ _ _ _ _] symbols appear under the relative deviation value in the “minor data” section of the display
- press the potentiometer knob. The display now includes cursor marks which point to the active digit. Turn the knob to change the value of the active digit
- press the potentiometer knob to change to the mode which allows to change the position of the active digit. ← and → symbols are displayed above the active digit. The position of the active digit can be changed by turning the knob.
- turn the knob to change back to the mode which allows to change the value of the active digit
- to get to the default screen, keep pressing the center cursor button until there is no [_ _ _ _ _] under any value, or press EXIT button. All values can be set using the buttons or the potentiometer.

If a non-zero relative deviation is set, the main data can be changed as well. The value of the output signal is always recalculated. If a zero relative deviation is set, the “minor data” section is not displayed.

Change of value by factor of ten

All functions of the calibrator allow the increase of the output value by 10 or reduction of the output value by 10. Such operation is equivalent to the change of internal range only in U, I, P-E modes. If the change results in overflow or underflow of calibrator’s range, an error message appears:

Value too large ! if the resulting value is too large

Value too small ! if the resulting value is too small

Range change

- Press the display button labeled “ x10 “ if you want to increase the range, “ :10 “ to decrease the range.
- The main value shown on the display is increased 10x (reduced 10x)

P-E function changes the current, not voltage, when the range is changed.

R-C function changes the set value 10x. The procedure, however, cannot be used to step the internal resistance/capacitance ranges, which are not decimal.

T function also has other than decimal ranges and the change of set value 10x therefore does not correspond to internal range change. Internal range change in this case depends on the temperature sensitivity of the resistance/capacitance.

Connection / disconnection of output terminals

After switching on the output terminals are disconnected in all modes. Press the OUTPUT button to connect the output signal to the terminals. Red LED above the OUTPUT button is lit and the information field on the display shows the following symbol  .

Press the OUTPUT button again to disconnect the output terminals. Red LED goes off and the information field on the display shows the following symbol OFF .

During mode change, output terminals are always disconnected. Output terminals are disconnected also when changing between voltage and current ranges or when changing between AC and DC ranges is performed.

If voltage over 100 V is set in the voltage mode, special algorithm must be followed to connect the output terminals. The algorithm is described in the „Generation of calibrated voltage“ chapter of this Manual.

Setting the frequency

Frequency can only be selected in AC voltage (ACU) mode, AC current (ACI) mode , power (P-E) mode and frequency (f) mode. In each mode the frequency has a slightly different meaning and the frequency is therefore set in a different manner.

AC voltage (ACU), AC current (ACI)

Set value of frequency is included in the “minor data” section of the display in ACU, ACI, P-E modes.

Frequency change

- First select the AC voltage or AC current mode by pressing U (I), AC buttons or selecting the P-E mode using the display. Frequency value „f = xxx.xx Hz“ appears in the “minor data” section of the display. “ f “ symbol is displayed above one of the display buttons.
- After “ f “ display button is pressed, [_ _ _ _ _] symbols appear below the frequency value. Numeric keyboard can be used to enter the desired value. Press “ Hz “ or “ kHz “ to confirm the value. The value can be set using the buttons or the potentiometer.

OUTPUT		13.00000 U	10.10.2000 12:21	<input type="checkbox"/> OFF
10.00000 U		U	~	Local GndU
Δ% = 30.0000%		f = 1000.00 Hz	2.003	Accuracy 0.033%
INPUT		Shape	Sine	
Hz	kHz			Exit

If too large or too small value is entered, the calibrator displays the maximum (minimum) value which is allowed for the selected function.

Frequency (F)

Set value of frequency is the main data on the display and the main parameter of the signal. Main data can be set by direct entry using the numeric keyboard, potentiometer or by changing the digit at the current cursor position. The setting procedure is described in the “Setting the value of output signal”.

OUTPUT		10.10.2000 12:23	<input type="checkbox"/> OFF
1.000000 kHz		Local	
$\Delta\%$ = 0E.0000%	U = 10.000 V		
PWM = 5E%	Shape PWM POS		
INPUT		Accuracy 0.0050%	
x 10	: 10	Shape	Setup

If frequency larger or smaller than the calibrator's range is entered, the calibrator displays an error message:
„Value is too large (small)“.

Generation of calibrated voltage

The multifunction calibrator provides calibrated DC and AC voltage. Output terminals for voltage ranges are labeled “Hi “ and “ Lo “ at the front panel. Depending on the setting of the calibrator, voltage up to 1000 Vef can be present at the terminals .

DC voltage range is 0 to 1000 V.

AC voltage range is 100 μ V to 1000 V.

Control in the voltage mode

- Press “U” button on the calibrator and then select AC or DC mode by pressing “DC-AC” button. The display shows the following data:
 - * main data of set voltage
 - * relative deviation
 - * uncertainty of output voltage
 - * frequency (when AC voltage is generated)
 - * total value of output voltage when non-zero relative deviation is set
- Set the desired value of voltage, including polarity when necessary, frequency and relative deviation. The signal is yet not connected to the output terminals. The information section of the display shows the symbol OFF which informs about the disconnection of output terminals.
- Press OUTPUT button.
- Red LED is lit above the OUTPUT terminals to signal the connection of the signal to the output terminals; the information section of the display shows the symbol .
- Calibrated voltage corresponding to set parameters is present at the output terminals.

Control sequence when output voltage over 100 V is selected

When output voltage over 100 V is selected, the information section of the display shows the symbol  which informs that a life-threatening voltage will be present at the output terminals. If the output terminals are currently connected, they will be disconnected when output voltage over 100 V is selected. OUTPUT button must be pressed to reconnect the output signal to the output terminals. After the OUTPUT button is pressed, an interrupted beep is sound, OUTPUT LED is lit and the information section of the display shows the symbol notifying the user about the connection of the dangerous output signal to the output terminals.

Voltage, polarity, frequency, absolute and relative deviation can be set without the outputs being disconnected. The output terminals are automatically disconnected when changing between AC and DC ranges or when changing the function mode.

Using AUTOCAL function

To remove the effect of short-term drift and temperature dependency of small DC voltages, AUTOCAL function can be used. It can only be activated in the calibration mode. "Calibration mode" lists the respective procedure.

Overloading of terminals

If the output terminals are overloaded or short-circuited in the voltage mode, the calibrator disconnects the signal from the output terminals and reports „Overload U output“ error.



ATTENTION DANGEROUS VOLTAGE

When working with voltages over 50 V, rules for work with dangerous voltage must be adhered to.

Never touch the measurement circuit when voltage over 50 V is set and output terminals are connected!



ATTENTION DANGEROUS VOLTAGE

When the calibrator is controlled remotely, it is not possible to disconnect the output voltage using the buttons located at the front panel!

The calibrator must be first switched to local control mode by pressing the LOCAL button and then the output terminals can be disconnected or the mains switch must be switched off !

Generation of calibrated current

The multifunction calibrator provides calibrated DC and AC current. Output terminals for voltage ranges are labeled “ +I “ and “ -I “ at the front panel. The terminals can carry high current and are the only terminals to which the calibrated object can be connected. Depending on the setting of the calibrator, current up to 20 A_{ef} can be driven by the terminals.

DC current range is 0 to 30 A

AC current range is 1μA to 30 A

When 25/50-turn coil (option 140-50) is used, AC current range is 50μA to 1000 A.

Control in the current mode

- Press “I” button on the calibrator and then select AC or DC mode by pressing “DC-AC” button. The display shows the following data:
 - * main data of set current
 - * relative deviation
 - * uncertainty of output current
 - * frequency (when AC current is generated)
 - * total value of output current when non-zero absolute or relative deviation is set
 - * time after which the output terminals will be disconnected when the output current over 10 A is selected.
- Set the desired value of voltage, including polarity when necessary, frequency and relative deviation. The signal is yet not connected to the output terminals. The information section of the display shows the OFF symbol which informs about the disconnection of output terminals.
- Connect the load or short the output terminals labeled +I, -I.
- Press OUTPUT button.
- Red LED is lit above the OUTPUT terminals to signal the connection of the signal to the output terminals; the information section of the display shows the symbol .
- Calibrated current corresponding to set parameters is driven by the output terminals.
- If COIL x 50 or COIL x 25 function is activated (see below - Setup functions menu), the optional 50-turn coil must be connected to output terminals. The calibrator can be used to calibrate 25 μA to 500 A or 50 μA to 1000 A ammeters. The calibrator generates AC and DC current within the range up to 20 A with current coil.



CAUTION

If GND terminal is connected to Lo, -I terminals, it is prohibited to connect external load to GND / Hi or GND / +I terminals. Such connection can damage the calibrator.

Overloading the terminals

When external circuit connected to current output terminals is disconnected or there is higher voltage at the load than permitted, the calibrator disconnects the output terminals and displays „Overload I output“ message. The same message can be displayed when 50-turn coil is used for AC current output at frequencies above 80 Hz. It depends on the set current and the type of ammeter connected.

If the output terminals are disconnected due to time limitation of output current over 10 A, the calibrator displays „Current timeout !“ message.

Generation of non-harmonic shapes

The multifunction calibrator can generate non-harmonic periodic signals with predefined shape. To allow the setting of a non-harmonic output shape, the calibrator must be switched to AC U or AC I mode. In both cases, an indication of the type of output shape (Shape xxxxx) is displayed under the frequency value. Press the respective display button to change the shape of the output signal.

The calibrator can generate the following shapes:

- SINE harmonic
- PWM POS squarewave - positive, with adjustable duty cycle
- PWM SYM squarewave - symmetrical, with adjustable duty cycle
- PWM NEG squarewave - negative, with adjustable duty cycle
- RAMP A ramp, symmetrical positive
- RAMP B ramp, symmetrical negative
- TRIANGLE triangular, symmetrical
- LIM SINE harmonic with amplitude limitation (truncated sin)

Generation of non-harmonic signals has some limitations:

- non-harmonic voltages can be generated in the 0.1 Hz to 1000 Hz frequency range
- non-harmonic currents can be generated in the 0.1 Hz to 120 Hz frequency range
- generation of these signals is limited to the voltage range up to 200 V and current range up to 2 A
- non-harmonic signals cannot be generated in the P-E (power-energy) mode.

Control in the non-harmonic mode

- Select AC voltage or AC current mode. The main section of the display shows the following data:
 - * main data of set current or voltage, unit of measurement
 - * relative deviation
 - * frequency
 - * selected SHAPE of the output signal
- Keep pressing SHAPE display button to select the desired shape of the output signal:

The output terminals are automatically disconnected when changing the shape of the output signal or when changing the relative deviation $\Delta\%$, if a non-zero relative deviation is set.

Displayed information

When non-harmonic output shape is selected, the display shows additional information:

- besides the main amplitude data, „pk“ index is displayed, notifying that the displayed main value is the peak value. Symbol which displays the shape of the output signal is displayed too.
- below the main data, an information about the shape type „Shape xxxxx“ is displayed.
- below the main data, calculated effective value of the output signal is displayed.
- for squarewave signals, set value of duty cycle „PWM= xx %“ is displayed.

OUTPUT		10.10.2000 12:29	[OFF]
030.0000 U _{pk} Γ ₋		Local	GndU
Δ% = 03.0000%	f = 1000.00 Hz	Accuracy	
PWM= 53%	Shape PlM POS	0.30%	
	U _{eff} = 015.0000 U		
INPLT		U DC	
x 10	: 10	Shape	f
		Setup	

Simulation of resistance and capacitance

The multifunction calibrator can simulate an exact value of resistance or capacitance. The outputs of the simulator are connected to Hi – Lo terminals and to AUXILIARY connector (pins 20, 21, 22, 23). 4W resistance is accessible only via cable adapter Opt. 70.

Only two-wire connection is available on the front panel terminals Hi-Lo. Both two-wire and four-wire connection is possible only through AUXILIARY connector. The terminals SIMHI - SIMLI are current terminals and SIMHU - SIMLU are voltage sensing terminals. Cable adapter Option 70 must be used for four-wire connection. Type of cable adapter currently connected to the AUXILIARY connector, is displayed on the display. If Option 70 is connected, label CA 140-70 is displayed in the right side.

Cable adapter Option 70 can be used for four-wire connecting of simulated resistance only. In compare with direct two-wire connection through output terminals Hi – Lo, accuracy of resistance is better with Option 70, see Technical data. When Cable adapter Option 70 is connected to the AUXILIARY connector, only resistance mode and resistance temperature simulation mode can be chosen.

The resolution of resistance and capacitance depends on the set value and corresponds to 0.01 % of set value. Minimum set value is 0.01 Ω

Resistance simulation range is 0 Ω to 1000 MΩ.

Capacitance simulation range is 0.7 nF to 100 μF.

Control in the resistance and capacitance mode

- press R-C button on the calibrator. The display shows the set resistance.
- If you want to simulate a capacitance, press R-C button again. The display shows the set capacitance.
- The display shows the following data:
 - * main data of set resistance (capacitance)
 - * relative deviation of resistance (capacitance)

- * uncertainty of set resistance (capacitance)
- * total value of resistance (capacitance) if non-zero deviation is set
- Set desired value of resistance (capacitance) or relative deviation. The value can be set using numeric keyboard, potentiometer or cursor buttons. Simulated resistance (capacitance) is not yet connected to the output terminals. The information section of the display shows the symbol which OFF informs about the disconnection of output terminals.
- Connect the object to be calibrated to the output terminals labeled Hi - Lo.
- Press OUTPUT button.
- Red LED is lit above the OUTPUT terminals to indicate the connection of simulated resistance (capacitance) to the output terminals. The information section of the display shows the symbol

Simulated resistance (capacitance) is connected to output terminals.

OUTPUT		8. 6.2000 12:26		<input type="checkbox"/> OFF
1.0000 μ F		$\Delta\% = 00.0000\%$		Local
				Accuracy 1.0%
INPUT		ACAL		
<input type="checkbox"/> x 10	<input type="checkbox"/> : 10			Setup

Setting relative deviation

- Keep pressing the center cursor button until [_ _ _ _ _] symbols appear under the relative deviation value ($\Delta\% = xx.xxxx\%$).
- The value can be set using numeric keyboard, potentiometer or cursor buttons. Confirm the value by pressing “%” display button or by pressing ENTER.

Limitations resulting from electronic simulation

Electronic simulation of resistance and capacitance allows setting of a wide range of values with accuracy sufficient for calibration of common multimeters. Electronic simulation has the following limitations:

- measurement current supplied by the multimeter to be calibrated must not exceed the value specified by the calibrator’s documentation. If the current is exceeded, the accuracy of simulated value is not guaranteed.
- maximum peak voltage at Hi - Lo terminals supplied by the multimeter to be calibrated must not exceed specified limits. If the test voltage is exceeded, calibrator disconnects output terminals. Overload message is displayed on the display.

Frequency dependence of resistance and capacitance

Electronic simulator of resistance can be used with DC and AC test signal. Electronic simulator of capacitance can be used in AC range from 20 Hz to 1000 Hz.



Generation of electric power and energy

The multifunction calibrator can generate exact value of electric power and energy. P-E function provides output voltage at Hi - Lo terminals and output current at +I - -I terminals. Lo and -I terminals are electrically connected.

Power setting range:	0.0 VA to 2400 VA
Voltage setting range:	0.2 V to 240 V
Current setting range:	0.01 A to 20 A (limited time in range 10 to 20 A)
Power factor setting range:	-1 to +1 (phase -90 to +90 °)
Frequency setting range:	DC, 40 Hz to 400 Hz

Control in power generation mode

- Press “P-E” button on the calibrator and then select AC or DC mode by pressing “DC-AC” button. The display shows set power value.
- The display shows the following data::
 - * main value of set power in selected unit of measurement VA, W, VAR
 - * power factor value PF in negative polarity LA or positive polarity LE or the phase shift between the voltage and current in °.
 - * frequency, if AC power is selected
 - * voltage at Hi - Lo terminals
 - * current through +I - -I terminals
 - * uncertainty of set power
 - * remaining time of output current ON state when current is set in range 10 to 20 A
- Set desired value of power using numeric keyboard, potentiometer or cursor buttons. Output power is not yet connected to the output terminals. The information section of the display shows the symbol which informs about the disconnection of output terminals..
- Connect the instrument to be calibrated to Hi - Lo and +I - -I terminals or short the +I - -I terminals.
- Press OUTPUT button.
- Red LED is lit above the OUTPUT terminals to indicate the connection of simulated electrical power to the output terminals; the information section of the display shows the symbol

OUTPJT	10.10.2000 12:34	<input type="checkbox"/>	
1.150000 kW 		Local	GndUI
PF = +1.000	∠ = 50.000 Hz	Accuracy	0.7%
U = 230.0000 V	I = 05.00000 A		
INPUT		V DC	
x 10	: 10	Mode	f
		Setup	

Desired power is connected to output terminals.

Display modes

The calibrator can display AC power in one of three ways:

- apparent power in VA
- active power in W
- reactive power in VAR

Keep pressing MODE display button to change the function mode. Along with mode change, the power display (depending on set power factor) and unit of measurement change as well. If DC power is generated, it is always displayed in Watts.

The calibrator can display the phase relation of output voltage and current as power factor (-1 to +1) or as phase shift in degrees (0 to 360 °). SETUP setup menu is used to change the method of displaying the phase relation.

Power setting modes

The calibrator allows several ways of setting the value of generated power.

1. Setting the main power value

- The main value can be changed using numeric keyboard, changing the digit at the cursor position after selecting the cursor position with <, > buttons, by range change using „x10“, „:10“ display buttons, or using the potentiometer.
- Output power is changed by changing the value of output current.

OUTPJT	10.10.2000 12:37	[OFF] ⚡
0.930000 kW ~		Local
Phase = 0.0° f = 50.000 Hz		GndUI
U = 230.0000 V I = 04.04348 A		Accuracy
		0.18%
INPUT		U DC
	f	Exit

2. Setting the voltage

- The main power value can be changed by changing the voltage.

OUTPUT		10.10.2000 12:38		OFF	
1.150000 kW				Local	
Phase = 0.0°		f = 50.000 Hz		GndUI	
U = 230.0000 U		I = 05.00000 A			
[225-----]				Accuracy	0.17%
INPUT				U DC	
μ U	mU	U		Exit	

- Select P-E mode and then keep pressing the center cursor button until [_ _ _ _ _] symbols appear under the voltage (U = xxx.xxxx V).
- The value can be set using numeric keyboard and confirmed by pressing μ V, mV, V display button. The value can be set using cursor buttons or potentiometer as well.
- Main power value is recalculated using new set voltage and existing setting of current and power factor.

3. Setting the current

- The main power value can be changed by changing the current..
- Select P-E mode and then keep pressing the center cursor button until [_ _ _ _ _] symbols appear under the current (I = xx.xxxx A).
- The value can be set using numeric keyboard and confirmed by pressing μ A, mA, A display button. The value can be set using cursor buttons or potentiometer as well..
- Main power value is recalculated using new set current and existing setting of voltage and power factor.

OUTPUT		10.10.2000 12:39		OFF	
1.150000 kW				Local	
Phase = 0.0°		f = 50.000 Hz		GndUI	
U = 230.0000 U		I = 05.00000 A			
[1.901-----]				Accuracy	0.17%
INPUT				U DC	
μ A	mA	A		Exit	

4. **Setting the power factor (AC power only)**

- If W or Var is indicated, the main power value can be changed by changing the power factor. Change of power factor does not change the output apparent power.
- Select P-E mode and then keep pressing the center cursor button until [_ _ _ _ _] symbols appear under the power factor symbols (PF = x.xxx LA (LE) or Phase = xxx.x).
- The value can be set using numeric keyboard and confirmed by pressing LA/LE (°) button or by pressing ENTER.
- Main power value is recalculated using new set power factor and existing setting of current and voltage. The calculation is only made if active or reactive power is displayed.

OUTPUT		10.10.2000 12:39	[OFF] ⚡
1.150000 kW		~	Local GndUI
PF = +1.000		f = 50.000 Hz	Accuracy 0.17%
[0.5] U = 230.0000 V		I = 05.00000 A	
INPUT		U DC	
LA	LE		Exit

In the power generation mode, relative deviation cannot be set.

If the power factor is set to define the phase relation of voltage and current, confirmation of entered value by pressing LA button means positive phase, LE means negative phase.

Setting the energy

Keep pressing the P-E button to switch to the energy generation mode. Auxiliary data display area shows the time in seconds and the energy delivered to output terminals after pressing the OUTPUT button given the existing setting of voltage, current, frequency and power factor. Time setting range is 1.1 s to 1999 s.

OUTPUT		10.10.2000 12:40	[OFF] ⚡
1.150000 kW		~	Local GndUI
PF = +1.000		f = 50.000 Hz	Accuracy 0.17%
U = 230.0000 V		I = 05.00000 A	
t = 60.0 s		E = 069.0000kWs	
INPUT		U DC	
x 10	: 10	Mode	f Setup

The energy value can be set in two ways:

Direct setting of energy

- Select the energy mode and then keep pressing the center cursor button until [_ _ _ _ _] symbols appear under the time value (E = xxx.xxxx) supplemented with indication of the set mode.
- The value can be set using numeric keyboard, cursor buttons or potentiometer and confirmed by pressing Ws/kWs/MWs, VAs/kVAs/MVAs or VArS/kVArS/MVArS display buttons depending on the set mode. The value can also be confirmed by pressing ENTER.
- Time value is recalculated using new set energy.

Setting the time

- Select the energy mode and then keep pressing the center cursor button until [_ _ _ _ _] symbols appear under the time value (t = xxx.x s).

OUTPUT		10.10.2000 12:41	[OFF] ⚡
1.150000 kW		~	Local GndUI
PF = +1.000	f = 50.000 Hz		
U = 230.0000 V	I = 05.00000 A		
t = 60.0 s	E = 069.0000kWs	Accuracy 0.17%	
[120 _ _ _ _ _]			
INPUT		V DC	
s			Exit

- The value can be set using numeric keyboard, cursor buttons or potentiometer and confirmed by pressing “s” display button depending on the set mode. The value can also be confirmed by pressing ENTER.
- Energy value is recalculated using new set time.

Grounding of the calibrator and the instrument to be calibrated in the P-E mode

When calibrating the power and energy meters with separate voltage and current circuits, it is advisable to select **GND U ON** and **GND I ON** (both grounding methods on) on the M-142 calibrator. This setting will ground both the current and voltage output of the calibrator.

If the instrument to be calibrated has electrically connected and not grounded current and voltage inputs, **GND U ON** and **GND I OFF** should be selected on the M-142 calibrator.

If Lo and -I terminals on the calibrator are connected AND the same terminals are connected at the instrument to be calibrated, resulting voltage drop at the current cables can damage the relay which interconnects Lo and -I terminals with GND terminal in the calibrator.

“Operating examples“ chapter provides more information concerning correct connection of powermeters and energy meters to the calibrator.

Uncertainty calculation of set power

Uncertainty of set power displayed on the Accuracy line of the display is calculated according to the following formula:

$$\text{for active power} \quad dP = \sqrt{(dU^2 + dI^2 + dPF^2 + 0.03^2)} \quad [\%]$$

$$\text{for reactive power} \quad dP = \sqrt{(dU^2 + dI^2 + dPF^{*2} + 0.03^2)} \quad [\%]$$

$$\text{for apparent power} \quad dP = \sqrt{(dU^2 + dI^2 + 0.03^2)} \quad [\%]$$

where	dP is the uncertainty of set power	[%]
	dU is the uncertainty of set voltage	[%]
	dI is the uncertainty of set current	[%]
	dPF is the uncertainty of set PF (cosφ)	[%]
	dPF* is the uncertainty of set sinφ	[%]

Generation of frequency

The multifunction calibrator can generate several different voltage shapes with exact frequency, amplitude and duty cycle. The output signal is present at BNC coaxial connector FREQ located at the front panel. The signal is not present at any other output terminal.

There are two frequency generation modes. The first mode (PWM) allows the generation of squarewave output signal with calibrated amplitude, frequency and duty cycle. Frequency range is up to 10 kHz. The second mode (HF) also provides squarewave output signal with very steep rising edge, typically less than 3 ns.

PWM mode

Frequency range:	0.1 Hz to 100 kHz
Voltage range:	1 mV to 10 Vpp
Signal shapes:	squarewave, negative PWM NEG – symmetrical PWM SYM – positive PWM POS

HF mode

Frequency range:	0.1 Hz to 20 MHz
Voltage range:	5 V _{pk-pk} 0, -10, -20, -30 dB
Signal shapes:	symmetrical squarewave

PWM mode can be used to calibrate the input sensitivity of oscilloscopes at frequencies up to 10 kHz. HF mode can be used to calibrate the time base of oscilloscopes.

To switch between the modes, keep pressing “F” direct mode button. The display includes the symbols for currently selected mode (PWM or HF).

Control in the frequency mode

- Press F direct mode button. The calibrator switches to PWM mode. If HF mode is desired, press F button once more. The main data on the display is the frequency.
- The display shows the following data:
 - * set frequency
 - * relative deviation of frequency
 - * signal amplitude (PWM mode) or attenuation (HF mode)

- * duty cycle (PWM mode only)
 - * signal shape: PWM NEG / POS / SYM (PWM mode only)
- Set the frequency using numeric keyboard, cursor buttons or potentiometer. Output signal is not yet connected to the output terminals. The information section of the display shows the symbol which OFF informs about the disconnection of output terminals...
 - Connect the object to be calibrated to FREQ terminal.
 - Press OUTPUT button.
 - Red LED is lit above the OUTPUT terminals to indicate the connection of signal to the output connector.

OUTPUT		10.10.2000 12:41		<input checked="" type="checkbox"/>
1.000000 kHz		□		Local
Δ% = 00.0000%		U = 10.000 V		
PWM = 50%		Shape PWM POS		Accuracy 0.0050%
INPUT				V DC
x 10	: 10	Shape		Setup

- Output signal with set frequency is present at the output connector.

Note

“FREQ” connector must not be overloaded. In 100 mV to 10V voltage range, maximum load is 5 mA. In other voltage ranges, maximum load is 0.1mA. If the output is overloaded, the set value is not guaranteed.

The output is short-circuit proof.

The outer casing of the connector is electrically connected to the chassis of the calibrator.

Setting relative deviation

- Keep pressing the center cursor button until [_ _ _ _ _] symbols appear under the relative deviation value $\Delta\% = xx.xxxx\%$.
- The value can be set using numeric keyboard, potentiometer or cursor buttons. Confirm the value by pressing “%” display button or by pressing ENTER.

Setting the amplitude

Signal amplitude in Volts can only be set in PWM mode.

- Select the frequency mode and keep pressing the center cursor button until [_ _ _ _ _] symbols appear under the amplitude value ($U = x.xxx\text{ V}$).

- Set the value using numeric keyboard and confirm by pressing “V” display button or by pressing ENTER.

OUTPUT		10.10.2000 12:42		<input type="checkbox"/>
1.000000 kHz		Local		
$\Delta\%$ = 00.0000%	U = 10.000 V	Accuracy		
PWM = 50%	[5.002	0.0050%		
	Shape PWM POS-]			
INPUT		U DC		
U				Exit

Setting the attenuation

Signal attenuation in dB can only be set in HF mode. Attenuation can be set in steps of (0, -10, -20, -30) dB.

- Select the frequency mode and keep pressing the center cursor button until [_ _ _ _ _] symbols appear under the attenuation value (a = x.xxx dB).
- Set the value using numeric keyboard and confirm by pressing dB display button or by pressing ENTER. If other than permitted value is set, the closest permitted value is used.

Setting the duty cycle

Duty cycle can only be set in PWM mode.

- Select the frequency mode and keep pressing the center cursor button until [_ _ _ _ _] symbols appear under the duty cycle value (PWM = xx %).
- Set the value using numeric keyboard, cursor buttons or potentiometer and confirm by pressing % display button or by pressing ENTER.

Setting the signal shape

Signal shape can only be set in PWM mode.

- Keep pressing SHAPE display button to select desired signal shape NEG – negative, SYM – symmetrical, POS – positive.
- Output signal of desired shape is connected to the output connector.

Simulation of temperature sensors

The multifunction calibrator can simulate resistance temperature sensors and thermocouples. When resistance temperature sensors are simulated, a simulated resistance corresponding to set temperature, sensor type and temperature scale is connected to Hi - Lo terminals. When thermocouples are simulated, a simulated voltage corresponding to set temperature, sensor type and temperature of cold end of thermocouple is connected to Hi - Lo terminals.

Simulated values of resistance temperature sensors are also available at the AUXILIARY connector. Four-wire connection of resistance temperature sensors is provided by current terminals PTLI, PTHI and voltage terminals PTLU, PTHU. Option 70 cable adapter has to be applied.

Temperature setting range:	-250 to +1820 °C depending on simulated sensor type
Sensor types:	resistance temperature sensor Pt 1.385, Pt 1.392, Ni thermocouple K, N, R, S, B, J, T, E
Temperature scale:	ITS 90, PTS 68 for resistance temperature sensors and thermocouples

Switching between resistance temperature sensors and thermocouples

- Press T button on the calibrator. The main value on the display is set temperature. The calibrator simulates a resistance temperature sensor.
- Press T button on the calibrator once again. The calibrator simulates a thermocouple.

Setting the temperature

- Press T button on the calibrator. The main value on the display is set temperature.
- The display shows the following data:

- * main data of temperature in °C or K
- * sensor type thermocouples: K, N, R, S, B, J, T, E
 resistance temperature sensors: Pt 1.385, Pt 1.392, Ni
- * resistance at 0 °C labeled R0 (resistance temperature sensors only)
- * cold junction temperature of thermocouple sensors labeled RJ
- * set value of relate deviation in %, labeled ΔT = xxxx.x °C (K)

the information section shows:

- * temperature scale type
 - * uncertainty of simulated temperature value of selected temperature sensor type
- Set the main value of temperature using numeric keyboard, cursor buttons or potentiometer. Output terminals are disconnected, the information section of the display shows the symbol OFF which shows that output terminals are disconnected.
 - Connect the object to be calibrated to Hi - Lo terminals.
 - Press OUTPUT button.
 - Red LED is lit above the OUTPUT terminal to indicate that the output signal is connected to output terminals. The display shows the symbol of connected output terminals.

OUTPUT			8. 6.2000 12:44	<input type="checkbox"/> OFF
0100.0 °C				Local ITS90
ΔT = 0000.0°C			RJ = 0023.0°C	
TC type T				Accuracy 0.4°C
U = +3.3672 mV				
INPUT				V DC
		TC type		Setup

Note

- Load of output terminals is limited similarly to corresponding voltage or current ranges.
- Output signals provided at Hi - Lo terminals and AUXILIARY connector are short-circuit proof.

Switching between temperature sensor types

- Keep pressing “TC type” or “RTD type” display button to select desired sensor type.
- If resistance temperature sensors are selected, each press of the button selects Pt1.385, Pt1.392 or Ni resistance thermometer. The display shows current setting as Pt385 / Pt392 / Ni.
- If thermocouples are selected, each press of the button selects K, N, R, S, B, J, T, E types. The display shows current setting as TC TYPE x, where x is the type of the thermocouple

Entry of R_0 coefficient for resistance temperature sensors

For resistance temperature sensors, resistance at 0 °C labeled R_0 can be set. The range is 20 Ω to 2k Ω for all types of resistance temperature sensors.

- Select the resistance temperature sensor mode and keep pressing the center cursor button until [_ _ _ _ _] symbols appear under the R_0 coefficient value ($R_0 = \text{xxxx } \Omega$).
- Set the value using numeric keyboard and confirm by pressing “ Ω ” or “k Ω ” display button or by pressing ENTER.

OUTPUT		8. 6.2000 12:45	[OFF]
0100.0 °C		Local	
		ITS90	
$\Delta T = 0000.0^\circ\text{C}$		$R_0 = 100 \Omega$	
Pt385		Accuracy	
		0.11 °C	
INPUT		U DC	
		RTD type	Setup

Note

After the calibrator is switched on or before the first change of the coefficient, R_0 is set to 100 Ω . This setting corresponds to Pt 100 resistance thermal sensor.

Entry of cold junction temperature

For thermocouples, the temperature of cold junction can be entered. The entry is performed by setting the RJ field in the auxiliary data section of the display.

- Select the thermocouple mode and keep pressing the center cursor button until [_ _ _ _ _] symbols appear under the (RJ = xxxx.x °C) value, if °C unit of measurement is used, or under (RJ = xxxx.x K) value, if K unit of measurement is used.
- Set the value using numeric keyboard.
- Confirm the value by pressing °C or K display button or by pressing ENTER.

OUTPUT		8. 6.2000 12:46		[OFF]
0100.0 °C		Local		
		ITS90		
ΔT = 0000.0°C		RJ = 0023.0°C		
TC type T		[28.5-----]		
		Accuracy		
		0.4°C		
INPUT				V DC
°C				Exit

Automatic compensation of cold junction temperature

Automatic cold junction TC sensors compensation can be performed, when cable adapter Option 140-01 is used for simulating. Ambient temperature measured by in cable adapter mounted Pt1000 sensor is taken as temperature of cold junction. This automatic compensation is performed always, when measuring of ambient temperature is activated on display (push button INPUT ON, green led lights). When temperature measuring is not activated or cable adapter Option 140-01 is not connected, manual compensation only is available. Set value of RJ on the display to the appropriate ambient temperature to compensate manually influence of cold junction.

Use of AUTOCAL function

To remove the effects of short-term drift and thermal dependency of the simulation, AUTOCAL function can be used. It can only be activated in the calibration mode. Procedure is following:

- Use a display button to enter the calibration menu. Enter the calibration code and confirm by pressing ENTER.
- Use the cursor buttons or potentiometer to select the AUTOCAL function from the calibration menu. After the function is activated, only one option - OFFSET ACAL - is provided. Press SELECT display button to confirm the option.
- Proceed according to the instructions provided on the display. Automatic calibration takes ca 8-10 minutes and prompts the user to short Hi-Lo circuits and then to disconnect them.
- After the calibration, the calibrator remains in the calibration mode. Press EXIT display button to return to normal display.

Do not connect anything to any terminals during the automatic calibration, with the exception of the prompt to short the Hi-Lo terminals. The procedure is described in "Calibration mode" chapter.

Multimeter

The calibrator includes a built-in multimeter which can measure many electrical and non-electrical values. Besides DC voltage and current, it can measure frequency, temperature and when external strain gauge sensors is connected, even other non-electrical values can be measured. The multimeter can only be connected through AUXILIARY connector. „Description of controls“ chapter lists the pins of the connector.

Option 40 cable adapter has to be applied to connect the multimeter.

The manufacturer does not recommend connection of multimeter inputs to calibrator outputs.

Such connection can result in presence of high voltage at multimeter inputs, which can damage the multimeter.

Basic menu

- Multimeter setting menu can be opened by pressing the METER direct control button. After the button is pressed, SETUP METER menu opens, which allows to set-up the multimeter. Press EXIT display button to return to previous menu.
- Press \wedge or \vee cursor button to browse the menu options. Active option is always inverted.
- The parameters of the active option can be changed if the respective function is allowed to be changed. Use UP, DOWN, CLR, NEXT and display buttons to change the parameters of the active option.
- Multimeter parameters can also be set using the potentiometer. The potentiometer can be used either to browse the menu options or to change the value of the active option. Press the knob to switch between these modes.
- Keep pressing EXIT display button to return to normal display when you are finished setting up the parameters.

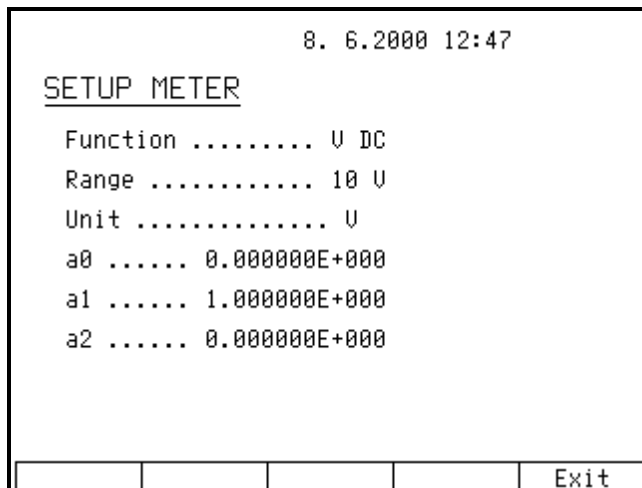

When the multimeter is being set-up, measurement cannot be initiated. Measurement can only be initiated after the menu is left using the INPUT button.

Function selection

- Press METER direct control button and select FUNCTION option from the menu using cursor buttons.
- Press UP, DOWN display buttons or use the potentiometer to select one of the following functions:
 - * basic DC voltage range VDC 10 V
 - * DC current mA DC 20 mA
 - * small DC voltage range mV DC up to 2 V
 - * four-wire resistance measuring range up to 2 k Ω
 - * frequency up to 15 kHz
 - * temperature measurement using thermocouples T TC
 - * temperature measurement using resistance temperature sensors T RTD
- By selection of the measurement function, some related options are automatically changed as well (measuring range, unit of measurement).
- Press EXIT display button the close the function selection menu and to return to the basic display.

Setting the measurement range

- Press METER direct control button and select RANGE option from the menu using cursor buttons.
- Press UP, DOWN display buttons or use the potentiometer to select the measurement range for selected function. Ranges of individual functions can be changed:
 - * small DC voltages mV DC ranges: 20, 200, 2000 mV
 - * temperature measurement using thermocouples T TC, types: K, N, R, S, B, J, T, E
 - * temperature measurement using RTD sensors, types: Pt 1.385, Pt 1.392

- After setting the range, use \wedge or \vee cursor buttons to switch to the previous or next menu option. The same can be achieved using the potentiometer after pressing the knob. Press EXIT display button the close the range selection menu and to return to the basic display.

Units of measurement

Unit of measurement can be set for each measurement function. The unit of measurement is displayed along with the measured value on the display. The description of the unit of measurement can consist of up to 4 characters.

- Press METER direct control button and select UNIT option from the menu using cursor buttons.
- Press the knob of the potentiometer to display \wedge and \vee symbols above the active character.
- Press UP, DOWN display buttons or use the potentiometer to select desired character at the active position.
- Press NEXT display button to move onto next character.
- Press the knob of the potentiometer to complete the setting.
- After the unit of measurement is selected, use \wedge or \vee cursor buttons to move onto the next menu option. The same can be achieved using the potentiometer after pressing the knob. Press EXIT display button the close the range selection menu and to return to the basic display.

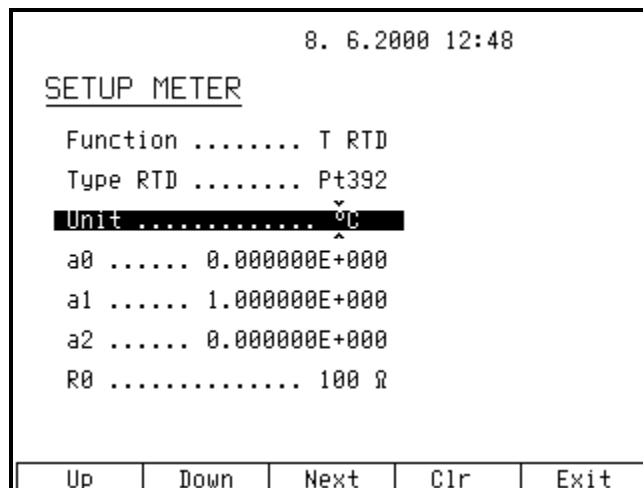

To reset the unit of measurement to original setting, press CLR display button. Original settings are listed below:

- | | |
|---|--------------------|
| * basic DC voltage range VDC | V |
| * DC current mA DC 20 mA | mA |
| * small DC voltages mV DC up to 100 mV | mV |
| * four-wire resistance measurement | Ω |
| * frequency up to 15 kHz | Hz |
| * temperature measurement using thermocouples | $^{\circ}\text{C}$ |
| * temperature measurement using resistive temperature sensors | $^{\circ}\text{C}$ |

Use of calculation formula

Each function of the multimeter can display recalculated measured value. The value shown on the display is always calculated according to the formula:

$$Y = A0 + A1 * X + A2 * X^2$$

where X is the value measured by the multimeter
Y is the value shown on the display

Default setting of the coefficients is $A0 = 0$, $A1 = 1$, $A2 = 0$. This means that directly measured value is displayed on the display. If any other recalculation is required, enter the desired parameters. Parameter A0 must be of the same dimension as is in row UNIT.

- Press METER direct control button and select A0 (A1, A2) option from the menu using cursor buttons.
- Enter new value using numeric keyboard.
- Confirm the value by pressing ENTER.
- After setting the coefficients, use \wedge or \vee cursor buttons to switch to the previous or next menu option. The same can be achieved using the potentiometer after pressing the knob. Press EXIT display button the close the range selection menu and to return to the basic display.

If you want to reset a coefficient to original setting, press CLR display button.

Each measurement function of the multimeter has its own independent set of coefficients.

Setting function parameters

Some measurement functions have additional parameters. When measuring the temperature using RTD sensors, R0 (resistance at 0 °C) can be set, when measuring the temperature using TC sensors, the temperature of cold junction can be set

Original settings are listed below:

T RTD	R0 = 100 Ω
T TC	RJ = 23 °C

The parameters can be changed as follows:

- Press METER direct control button and select a function, then use cursor buttons to select the line which includes the function parameter.
- Enter new value using numeric keyboard.
- Confirm the value by pressing ENTER.
- After setting the coefficients, use \wedge or \vee cursor buttons to switch to the previous or next menu option. The same can be achieved using the potentiometer after pressing the knob. Press EXIT display button the close the range selection menu and to return to the basic display.

Start of measurement

To start a measurement:

- Press INPUT direct control button in the basic state of the calibrator.
- INPUT field on the display shows the measured value. The measurement is indicated by a green LED above the INPUT button.
- Press INPUT button again to stop the measurement. The LED goes off and the input connectors are disconnected.

OUTPUT		10.10.2000 12:48		[OFF]
05.00000 U =		Local		GndU
Δ% = 00.0000%		Accuracy		0.0050%
INPUT		mA DC		
10.0003 mA				
x 10	: 10		+/-	Setup

The multimeter does not display uncertainty of measuring. If the input range is exceeded, OVERFLOW message is displayed.

Zero function

The multimeter has a zeroing function. It can be activated after the measurement was activated by pressing INPUT direct control button. Zeroing is performed by pressing METER direct control button. After the button is pressed, most recent value is stored and subtracted from all ongoing measured values. A “Zero” message appears on the right side of the display, indicating that this function is active. Press METER a second time to deactivate the Zeroing function.

Multimeter’s menu can be entered only after the measurement is terminated by pressing INPUT button.

OUTPUT		10.10.2000 12:48	[OFF]
05.00000 U =		Local	GndU
Δ% = 00.0000%		Accuracy	0.0050%
INPUT		mA DC	Zero
- 0.0002 mA			
x 10	: 10	+/-	Setup

Zeroing function can be used e.g. to compensate the voltage drops at the cables, to suppress any remanent value of the signal etc.

Overloading can damage the multimeter.

Notes:

- * The multimeter can be used as a DC milivoltmeter with 20 mV, 200 mV, 2 V, 10 V ranges. The appropriate input terminals are PTHU and PTLU.
- * Maximum allowed voltage on the input terminals against ground terminal is 20 V.
- * Frequency measurement is possible up to 15 kHz. Input signal must be within 0.2 to 5 V range. Square wave or pulse shape of the input signal is expected.

Simultaneous functions

The multifunction calibrator allows simultaneous generation of calibrated signal along with measurement of another signal using the built-in multimeter. To use both parts of the calibrator simultaneously, cable adapters supplied by the manufacturer are necessary.

When using the calibrator, the following states are possible; each state has its limitation, listed in the table.

	<i>Cable adapter applied</i>	<i>Limitation of output signals</i>	<i>Limitation of multimeter's function</i>	<i>Method of connection</i>
1	No cable adapter is used.	Calibrator output signals are not limited in any way and can be fully used. Calibrator output signals are available at the terminals located at the front panel.	The multimeter cannot be used. If the multimeter is activated, FAIL error message appears.	
2	The calibrator is used with 140-01 cable adapter.	Calibrator output signals are not limited in any way and can be fully used. Calibrator output signals are available only at the terminals located at the cable adapter.	The multimeter can only be used to measure the external temperature using a Pt100 sensor built into the adapter.	140-01 cable adapter connected onto calibrator's terminals.
3	The calibrator is used with Option 40 Canon – 2 banana cable end.	Calibrator output signals are not limited in any way and can be fully used. Calibrator output signals are available on the terminals located at the front panel.	The multimeter can be used in the following ranges: - DC voltage up to 12 V - DC voltage up to 25 mA - frequency up to 15 kHz.	Option 40 Cable, connected onto calibrator's AUXILIARY connector.
4	The calibrator is used with Option 60 Canon – 4 banana cable end..	Calibrator output signals are not limited in any way and can be fully used. Calibrator output signals are only available at the terminals located at the front panel.	The multimeter can only be used in the following ranges: - temperature using TC sensors - temperature using RTD sensors - resistance up to 2 kOhm	Option 60 cable end , connected onto calibrator's AUXILIARY connector
5	The calibrator is used with Option 70 Canon – 4 terminals.	Following output signals can be set only: - resistance in four-wire connection - resistance temperature sensor simulation in four-wire connection Output signals are available on adapter Option 70 only.	Multimeter cannot be used. If the multimeter is activated, FAIL error message appears.	Cable adapter Option 70, installed on AUXILIARY connector.
6	The calibrator is used with Option 80 Canon – 2 terminals	Calibrator output signals are not limited in any way and can be fully used. Calibrator output signals are available on the terminals located at the front panel.	The multimeter can be used in the following ranges: - mVDC voltage up to 2 V - TC temperature measurement using external TC sensor	Option 80 Cable, connected onto calibrator's AUXILIARY connector.
7	The calibrator is used with Option 90 Pt100 external temperature sensor.	Calibrator output signals are not limited in any way and can be fully used. Calibrator output signals are available on the terminals located at the front panel.	The multimeter can be used in the following ranges: - RTD temperature measurement only	Option 90 Cable, connected onto calibrator's AUXILIARY connector.

Tab. 5 Cable adapters description

Setup menu

The multifunction calibrator allows many other, less frequently used parameters to be set. Setup menu is used to set these parameters. Setup menu is opened by pressing SETUP display button. If output terminals are connected, they will be disconnected and the following display appears:

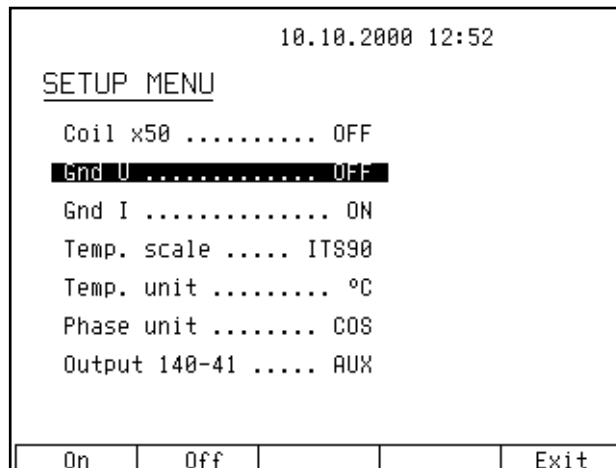

Use \wedge or \vee cursor button or the knob of the potentiometer to browse the menu options. Active option is always inverted and when changed, the descriptions of display buttons change as well. Display buttons show how the respective parameter can be set. Each parameter can be changed after the knob of the potentiometer is pressed. Press EXIT display button twice to save the parameters when the setting is completed. New settings are retained when the calibrator is switched off. Setup menu offers the following options:

1. **Current Coil xx x25/x50/OFF**

This parameter can be set on when 50-turn current coil is going to be used for clamp ammeter calibration. The coil multiplies the output current either 25 times or 50 times depending on set parameter. OFF is set by the manufacturer.

2. **GND U xx ON/OFF**

This parameter connects Lo terminal to GND. In practice this means that Lo terminal is grounded. By pressing the display buttons, the terminal can be grounded or ungrounded. ON is set by the manufacturer, output terminal is grounded.

3. **GND I xx ON/OFF**

This parameter connects -I to GND. In practice this means that -I terminal is grounded. By pressing the display buttons, the terminal can be grounded or ungrounded. OFF is set by the manufacturer, output terminals are not grounded.

It is recommended to ground only the voltage channel GND U ON, GND I OFF, for all ranges except the generation of power or energy. If the meter to be calibrated has Lo terminal grounded, it is recommended to unground both outputs of the calibrator, GND U OFF, GND I OFF to exclude ground loops.

Note

If neither the calibrator's output, nor the meter's inputs are grounded, signal/noise ratio can arise at the calibrator's output.

4. Temp.scale xx ITS90/PTS68

This parameter allows the temperature scale for platinum resistance temperature sensors to be selected. Pressing the display buttons allows to switch between ITS90 and PTS68 temperature scales. ITS90 is set by the manufacturer.

5. Temp.unit xx °C/K

This parameter allows the temperature unit for simulation of temperature sensors to be selected. Pressing the display buttons allows to switch between °C and K. °C is set by the manufacturer.

6. Phase.unit xx °/cos

This parameter allows the unit of phase shift between the voltage and current output to be selected in the power/energy generation mode. Pressing the display buttons allows to switch between ° and COS (degrees and power factor).

7. Meter average xx UP/DOWN

Displays the number of measurements taken before the average value of build-in multimeter is displayed (integration constant). UP, DOWN display buttons can be used to select a value in the range of 1 to 20. The higher the value, the longer the calibrator needs to measure a value, but displayed value is more stable. If 20 is set, one measurement takes approximately 2.5 s.

8. Interface xx GPIB/RS232

Displays the type of interface used to control the calibrator from a PC. By pressing GPIB or RS232 buttons, the respective type can be selected. The calibrator can be remotely controlled only using the selected interface.

9. GPIB address xx UP/DOWN

Displays the calibrator's address at the GPIB bus. UP, DOWN display buttons can be used to select any valid GBIP address in the range of 00 to 30. The address 02 is set by the manufacturer.

10. RS232 baud rate xx UP/DOWN

Indicates the communication speed of RS232 bus. UP/DOWN display buttons can be used to select 150, 300, 600, 1200, 2400, 4800, 9600, 19200. Perfect communication with the PC requires equal values set at the PC and the calibrator.

11. Handshake xx OFF/Xon-Xoff

Indicates the communication handshake. Display buttons can be used to select OFF or Xon/Xoff. Perfect communication with the PC requires equal values set at the PC and the calibrator.

12. Keyb.beep xx ON/OFF

This parameter allows the acoustic indication of pressed buttons to be switched off or on. ON and OFF display buttons can be used to switch the indication off or on. ON is set by the manufacturer.

This parameter does not control the acoustic indication of output voltages over 100 V and identification of errors.

13. Keyb.volume xx UP/DOWN

This parameter allows the volume of acoustic indication to be set. UP and DOWN display buttons allow to set the value in the range of 00 to 15. The bigger the value, the louder sound. This parameter controls the volume of keyboard beep (if switched on), indication of output voltages over 100 V and identification of errors when controlling the calibrator.

14. Brightness xx UP/DOWN

This parameter sets the contrast of the display. UP and DOWN display buttons allow to set the value in the range of 00 to 15.

15. Rotary change xx ON/OFF

This parameter controls the range of functions of the potentiometer. If ON is set, the potentiometer can move the cursor both to the left and right (← and → symbols) and up and down (∧ and ∨ symbols). If OFF is set, the potentiometer can move the cursor up and down only (∧ and ∨ symbols).

16. Switch polarity xx ON/OFF

This parameter controls the function of the built-in relay. If ON is set, the relay is closes before the test. If OFF is set, the relay is opens before the test.

17. Switch activity xx PASS/FAIL

This parameter controls the function of the built-in relay. If PASS is set, the relay is active (changes its status) if the test results in PASS status. If FAIL is set, the relay is active (changes its status) if the test results in FAIL status.

18. Cal.code 00000

Entry of calibration code. Calibration code is a five-digit number, which must be entered to access the calibration mode. If the calibration code is set to "00000", this information is displayed in the Setup menu. Calibration code can be changed. New calibration code can be directly entered using numeric keyboard and confirmed by pressing ENTER. If non-zero calibration code is set, correct calibration code must be entered to access the calibration mode. Non-zero calibration code is not displayed further on the display.

The purpose of the calibration code is to prevent unauthorized users from changing the calibration of the instrument.

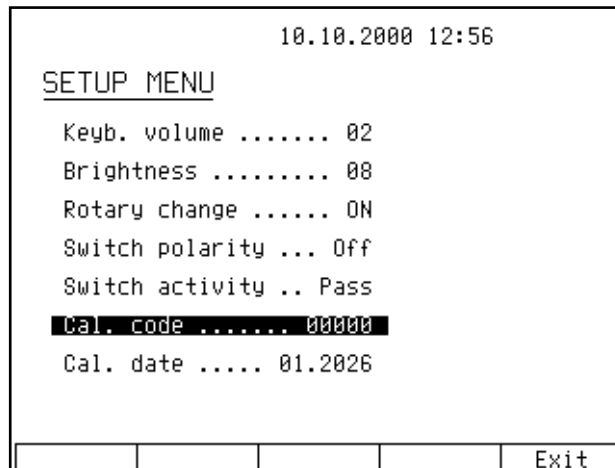
*Note*

It is advisable to write down actual calibration code if changed. If you forget the calibration code, you have to send the calibrator to the manufacturer.

19. **Cal.date xx.yyyy**

Displays the date of last calibration of the calibrator (month/year). The parameter cannot be changed, as it is automatically recorded when leaving the calibration mode.

20. **Serial No xxxxxx**

Displays the serial number of the calibrator. The parameter cannot be changed.

21. **Time xx:yy**

Displays real time. The parameter can be changed using HOUR UP, HOUR DO, MIN UP, MIN DO. display buttons.

22. **Date xx.yy.zzzz**

Displays real time. The parameter can be changed using DAY UP, MONTH UP, YEAR UP, YEAR DO display buttons.

23. **Time on display xx ON/OFF**

If set to ON, time and date are displayed in the upper part of the display. If OFF is set, time and date are not displayed. ON is set by the manufacturer.

Calibration mode

The multifunction calibrator includes a calibration procedure, which allows calibration of the calibrator. Zero point and slope of the characteristics of individual generation and measurement ranges are set during the calibration in predefined order. The calibration can only be controlled using the buttons and menu on the calibrator.

The calibration mode includes AUTOCAL autocalibration function. This function can automatically correct the short-term instability of zero point for voltage ranges up to 20 V. This function is not a part of the complete calibration procedure, but it can be used to reduce the time and temperature dependent drift of zero point when calibrating using small DC voltages and when simulating the thermocouples.

Calibration principles

The calibrator can be calibrated:

- completely, i.e. all functions are calibrated in all recommended points
- partially, i.e. only selected functions are calibrated in all recommended points
- partially, i.e. only selected functions are calibrated in selected points

Complete calibration consists of all partial calibrations performed in the order defined by the calibration menu. If an item of the calibration menu, e.g. "VOLTAGE DC" is selected, it is not necessary to calibrate all ranges defined by the calibration algorithm. If new calibration of all ranges is not possible (e.g. the required standard is not available), old calibration data can be confirmed, i.e. current step of the calibration can be skipped.

Calibration interruption can be performed in any point of the calibration procedure. However this particular calibration influences parameters of the calibrator.

Accuracy of the calibrator is guaranteed when full calibration was done.

DC voltage calibration is performed by setting the zero and slope of the scale in all ranges and in both signal polarities (+ and -) (except the 1000 V range, where zero correction is not necessary).

AC voltage calibration is performed by setting the zero and slope of the scale in all ranges at 1000 Hz (except the 1000 V range, where the calibration is performed at 500 Hz).

DC current calibration is performed by setting the zero and slope of the scale in all ranges and in both signal polarities (+ and -).

AC current calibration is performed by setting the zero and slope of the scale in all ranges at 1000 Hz (except the 20 A, where the calibration is performed at 120 Hz).

AC and DC power calibration is performed by calibration of DC and AC current. The phase relationship of voltage and current (power factor) is defined digitally and cannot be calibrated. It can only be checked. The respective check is not included in the calibration procedure.

Resistance calibration is performed by setting the zero and slope of the scale in all ranges. Slope of each range is calibrated twice. In practice, 9 internal range resistances (50 Ω to 1000 M Ω) must be measured and the measured value entered into the calibrator; then the zero point of the scale is adjusted for each range. Calibration of resistance ranges must be performed using AUXILIARY connector and cable adapter Option 70 in range 0 to 100 k Ω , and directly from Hi – Lo output terminals in range above 100 k Ω .

Capacitance calibration is performed by setting the zero and slope of the scale in all ranges. Slope of each range is calibrated twice. In practice, 9 internal capacitance ranges (1 nF to 100 μ F) must be measured and the measured value entered into the calibrator; then zero point of the scale is adjusted for each range.

Frequency function calibration is performed by calibration of DC voltage range and zero point check. DC voltage levels are checked, between which the calibrator switches when generating the signal. The accuracy of PWM of the square wave output signal depends on the frequency accuracy and cannot be calibrated, it can only be checked. The respective check is not included in the calibration procedure.

Multimeter is calibrated on voltage ranges 20 mV, 200 mV, 2 V and 10 VDC, on current range 20 mA DC and on resistance range 100 Ω and 1000 Ω . For calibration cable adapters Option 40 (10V range voltage, current), Option 80 (20mV/200mV/2V range voltage) and Option 60 (resistance) must be used.

Access to the calibration procedure

Calibration code is required to access the calibration procedure.

- Press SETUP to open the setup menu.
- Press CALIB display button.
- Concerning cable adapters, access to the calibration mode is permitted without connected any of cable adapters or with connected cable adapter Option 40, Option 60, Option 70 and Option 80. If cable adapter Option 140-01 is connected to the AUXILIARY connector, access to calibration mode is not permitted. Calibrator will display message:

```
Err 9
Bad cable adapter !
```

- If an attempt is made to access the calibration procedure within 60 minutes after the calibrator was switched on, the calibrator does not open the respective menu and displays the following message instead:

```
Err 21
Time warm up !
xx minutes remain
```

- If the calibrator is already on for at least 60 minutes, it requests the entry of the calibration code after CAL. MODE display button is pressed.

CALIBRATION MENU				OFF
Set calibration code				
[00000]				
SELECT				Exit

- Enter the correct calibration code using numeric keyboard and press ENTER.

- If incorrect calibration code is entered, an error message appears on the display for approximately 3 seconds:

Err 20
Bad calib. code!

- If correct calibration code is entered, calibration menu appears:

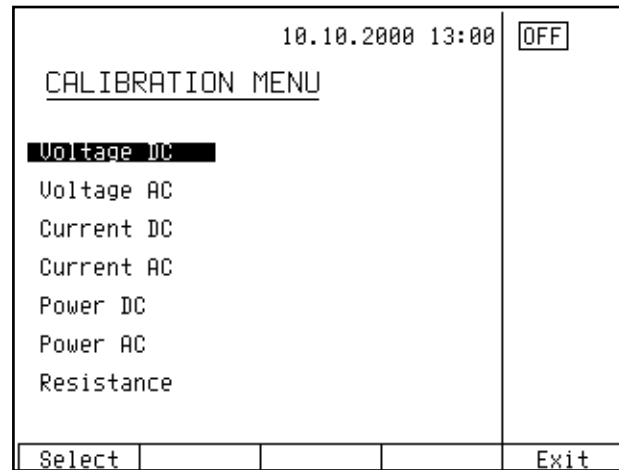

- Use ^ and v cursor buttons to move the cursor through the list:

1.	VOLTAGE DC	All DC voltage ranges calibration
2.	VOLTAGE AC	All AC voltage ranges calibration
3.	CURRENT DC	All DC current ranges calibration
4.	CURRENT AC	All AC current ranges calibration
5.	POWER DC	DC power calibration
6.	POWER AC	AC power calibration
7.	RESISTANCE	Resistance calibration
8.	CAPACITANCE	Capacitance calibration
9.	FREQUENCY	Amplitude in frequency mode calibration
10.	ANALOG INPUT	Multimeter calibration
11.	AUTOCAL	DC voltage offset correction

Selection of calibration type

After the calibration menu is displayed, one of partial calibrations can be selected. Use ^ and v cursor buttons to move the cursor through the list. Having selected the required function to be calibrated, press SELECT display button. The following data are shown (the following example is valid for VOLTAGE DC range):

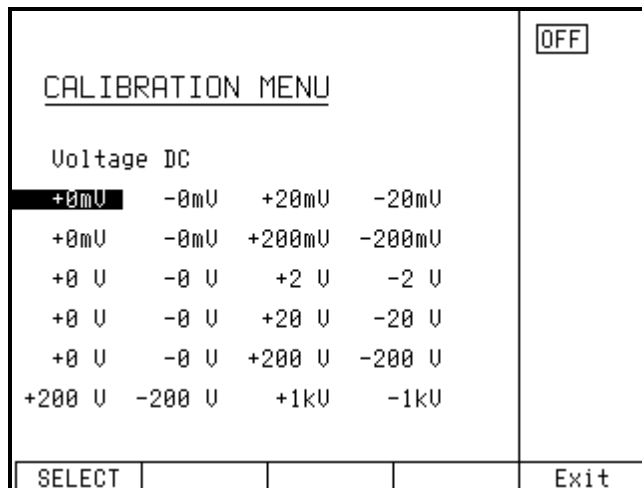

The table lists recommended calibration points. Having selected the required calibration point using SELECT display button, the following data are shown.

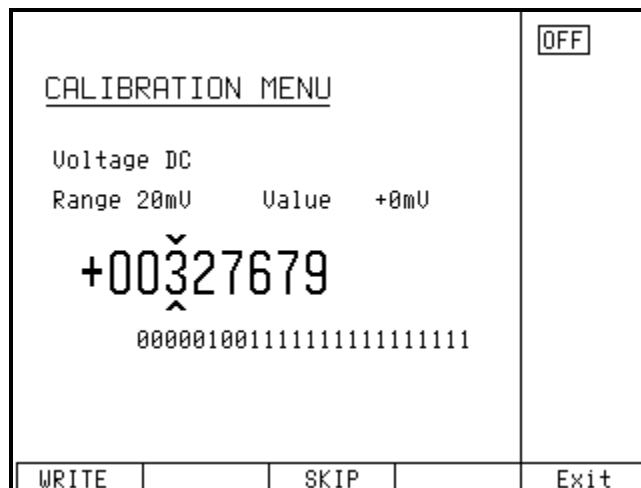

Display buttons have the following meaning:

- WRITE new calibration value is entered into the memory, old value is irreversibly lost
- SKIP current calibration step is skipped, old value is retained in the memory
- EXIT current calibration is terminated. After this button is pressed, the calibration memory hold all data (old or new entered) and the calibrator returns to the calibration menu. It is not necessary to calibrate all ranges; calibration of only selected ranges is possible by skipping the ranges which do not need to be calibrated.

Moreover, the display shows the range which is being calibrated (RANGE), and the value to be set at the external standard multimeter (VALUE).

Setting the new calibration data

Use ^, v, <, > cursor buttons to set such main data on the display, when the output signal measured by external standard multimeter reaches the required calibration point. When the standard output value is reached, press "WRITE" to write new calibration value to the calibration memory. If you press "SKIP" button, the calibrator

ignores the new value and old value is retained. After you press “WRITE” (or “SKIP”), the calibrator moves on to the next calibration point.

The procedure is repeated for all calibration points of the selected function. If you press “EXIT” button before completing the calibration, the calibrator returns to the calibration menu.

Termination of calibration

The calibration can be terminated in the following cases:

- complete calibration has been performed, new calibration data have been entered, the program has returned to the calibration menu,
- calibration of selected function has been performed, new calibration data have been entered, the program has returned to the calibration menu,
- calibration of selected range(s) of selected function has been performed, new calibration data have been entered, the program has returned to the calibration menu,
- the calibration has been started but no calibration data have been entered, the program has returned to the calibration menu after “EXIT” display button has been pressed,

Press “EXIT” display button to terminate the calibration. After the button is pressed, the calibration data is saved internally and the calibrator returns to the state it was in before the calibration has been started.

Calibration points

Each function of the calibrator has assigned fixed calibration points which have to be set during the calibration. For VOLTAGE DC, VOLTAGE AC, CURRENT DC, CURRENT AC, POWER AC, POWER DC, F functions, the signal value is set using the keyboard. For R-C functions and partially also during the calibration of the multimeter, calibration data of the range resistances must be entered. T function does not require any calibration, as the output voltage or resistance is based on arithmetic interpolation using standard tables of temperature sensor values.

The calibrator needs no calibration of the following parameters:

- frequency
- phase relationship (power factor) of output voltage and frequency in AC power/energy generation mode
- DC and AC power (except DC and AC current in this mode)

VOLTAGE DC function

<i>nominal value [V]</i>	<i>set limits [V]</i>	<i>range [V]</i>	<i>note</i>
0.0	2 u	20 m	zero calibration
0.0	2 u	-20 m	zero calibration
19 m	4 u	20 m	slope calibration
-19 m	4 u	-20 m	slope calibration
0.0	2 u	200 m	zero calibration
0.0	2 u	-200m	zero calibration
190 m	6 u	200 m	slope calibration
-190 m	6 u	-200m	slope calibration
0.0	5 u	2	zero calibration
0.0	5 u	-2	zero calibration
1.9	12 u	2	slope calibration
-1.9	12 u	-2	slope calibration
0.0	20 u	20	zero calibration
0.0	20 u	-20	zero calibration
19	100 u	20	slope calibration
-19	100 u	-20	slope calibration
0.0	200 u	200	zero calibration
0.0	200 u	-200	zero calibration
190	600 u	200	slope calibration
-190	600 u	-200	slope calibration
1000	20 m	1000	slope calibration
-1000	20 m	-1000	slope calibration

Tab.6 DC VOLTAGE

VOLTAGE AC function

<i>nominal value [V]</i>	<i>set limits [V]</i>	<i>range [V]</i>	<i>recommended frequency[Hz]</i>
1.9 m	5 u	20 m	1000
19 m	10 u	20 m	1000
19 m	15 u	200 m	1000
190 m	40 u	200 m	1000
190 m	30 u	2	1000
1.9	100 u	2	1000
1.9	200 u	20	1000
19	1 m	20	1000
19	5 m	200	1000
190	10 m	200	1000
190	50 m	1000	1000
750	50 m	1000	500

Tab.7 AC VOLTAGE

Other than recommended frequencies can be used for calibration. Specification of the calibrator is valid when recommended frequency is used.

CURRENT DC function

<i>nominal value [A]</i>	<i>set limits [A]</i>	<i>range [A]</i>	<i>note</i>
0.0	3 n	200 u	zero calibration
0.0	3 n	-200 u	zero calibration
190 u	5 n	200 u	slope calibration
190 u	5 n	-200 u	slope calibration
0.0	20 n	2 m	zero calibration
0.0	20 n	-2 m	zero calibration
1.9 m	50 n	2 m	slope calibration
1.9 m	50 n	-2 m	slope calibration
0.0	100 n	20 m	zero calibration
0.0	100 n	-20 m	zero calibration
19 m	200 n	20 m	slope calibration
-19m	200 n	-20 m	slope calibration
0.0	1 u	200 m	zero calibration
0.0	1 u	-200 m	zero calibration
190 m	2 u	200 m	slope calibration
-190 m	2 u	-200 m	slope calibration
0.0	20 u	2	zero calibration
0.0	20 u	-2	zero calibration
1.9	50 u	2	slope calibration
-1.9	50 u	-2	slope calibration
0.0	300 u	20	zero calibration
0.0	300 u	-20	zero calibration
10	600 u	20	slope calibration
-10	600 u	-20	slope calibration

Tab.8 DC CURRENT

CURRENT AC function

<i>nominal value [A]</i>	<i>set limits [A]</i>	<i>range [A]</i>	<i>recommended frequency[Hz]</i>
19 u	5 n	200 u	1000
190 u	50 n	200 u	1000
190u	40 n	2 m	1000
1.9 m	200 n	2 m	1000
1.9 m	200 n	20 m	1000
19 m	2 u	20 m	1000
19 m	2 u	200 m	1000
190 m	20 u	200 m	1000
190 m	20 u	2	500
1.9	200 u	2	500
1.9	1 m	20	120
10	3 m	20	120

Tab.9 AC CURRENT

Other than recommended frequency can be used for calibration. Specification of the calibrator is valid when recommended frequency is used.

POWER DC function **DC current calibration**

<i>nominal value [A]</i>	<i>set limits [A]</i>	<i>range [A]</i>	<i>note</i>
0.0	400 n	20 m	zero calibration
0.0	400 n	-20 m	zero calibration
19 m	2 u	20 m	slope calibration
-19m	2 u	-20 m	slope calibration
0.0	2 u	200 m	zero calibration
0.0	2 u	-200 m	zero calibration
190 m	20 u	200 m	slope calibration
-190 m	20 u	-200 m	slope calibration
0.0	50 u	2	zero calibration
0.0	50 u	-2	zero calibration
1.9	200 u	2	slope calibration
-1.9	200 u	-2	slope calibration
0.0	200 u	10	zero calibration
0.0	200 u	-10	zero calibration
10	1 m	10	slope calibration
-10	1 m	-10	slope calibration

Tab.10 DC POWER

POWER AC function **AC current calibration**

<i>nominal value [A]</i>	<i>set limits [A]</i>	<i>range [A]</i>	<i>recommended frequency[Hz]</i>
1.9 m	400 n	20 m	120
19 m	2 u	20 m	120
19 m	2 u	200 m	120
190 m	20 u	200 m	120
190 m	20 u	2	120
1.9	200 u	2	120
1.9	200 u	10	120
10	1 m	10	120

Tab.11 AC POWER

Other than recommended frequency can be used for calibration. Specification of the calibrator is valid when recommended frequency is used.

RESISTANCE function

<i>nominal value [Ω]</i>	<i>set limits [Ω]</i>	<i>range [Ω]</i>
0	0.002	10
10	0.002	10
33	0.002	10 – 33
33	0.002	33 – 100
100	0.005	33 – 100
100	0.005	100 – 330
330	0.012	100 – 330
330	0.012	330 – 1 k
1 k	0.025	330 – 1 k
1 k	0.025	1 k – 3k3
3k3	0.100	1 k – 3k3
3k3	0.100	3k3 – 10 k
10 k	0.25	3k3 – 10 k
10 k	0.25	10 k – 33 k
33 k	1	10 k – 33 k
33 k	1	33 k – 100 k
100 k	2.5	33 k – 100 k
100 k	2.5	100 k – 330 k
330 k	10	100 k – 330 k
330 k	10	330 k – 1 M
1 M	50	330 k – 1 M
1 M	50	1 M – 3M3
3M3	400	1 M – 3M3
3M3	400	3M3 – 10 M
10 M	2 k	3M3 – 10 M
10 M	2 k	10 M – 33 M
33 M	15 k	10 M – 33 M
33 M	15 k	33 M – 100 M
100 M	50 k	33 M – 100 M
190 M	100 k	100 M – 330 M
1 G	1 M	330 M – 1 G
22 k	0.4	linearity
22 k	0.4	linearity

Tab.12 Resistance

Calibration in resistance range of calibration points from 0 Ω to 100 k Ω must be done using Option 70 cable adapter (four-terminal connection). Four-wire output resistance is defined at the test leads of the cable adapter.

Calibration in resistance range of calibration points from 100 k Ω to 1 G Ω must be done without Option 70 cable adapter application (two-terminal connection). Use front panel terminals Hi-Lo for connection of standard ohmmeter.

CAPACITANCE function

<i>nominal value [F]</i>	<i>set limits [F]</i>	<i>range [F]</i>
700 p	5 p	700 p – 1 n
1 n	5 p	1 n – 3.3 n
3.3 n	5 p	1 n – 3.3 n
3.3 n	5 p	3.3 n - 10 n
10 n	10 p	3.3 n - 10 n
10 n	10 p	10 n – 33 n
33 n	10 p	10 n - 33 n
33 n	50 p	33 n - 100 n
100 n	50 p	33 n - 100 n
100 n	50 p	100 n - 330 n
330 n	250 p	100 n - 330 n
330 n	250 p	330 n – 1 u
1 u	250 p	330 n – 1 u
1 u	1 n	1 u – 3.3 u
3.3 u	2 n	1 u – 3.3 u
3.3 u	2 n	3.3 u – 10 u
10 u	5 n	3.3 u – 10 u
10 u	5 n	10 u – 100 u
100 u	5 n	10 u – 100 u

Tab.13 Capacitance

FREQUENCY function amplitude calibration

<i>nominal value [V]</i>	<i>set limits [V]</i>	<i>range [V]</i>	<i>note</i>
0.0	10 u	--	zero calibration
10	1 m	10	slope calibration

Tab.14 Frequency

ANALOG INPUT multimeter function voltage, current, resistance calibration

<i>nominal value [-]</i>	<i>set limits [-]</i>	<i>range [-]</i>	<i>note</i>
0 V	50 u	10 V	zero calibration
10 V	200 u	10 V	slope calibration
0 mA	50 nA	20 mA	zero calibration
19 mA	500 nA	20 mA	slope calibration
0 Ω	5 mΩ	200 Ω	zero calibration
100 Ω	5 mΩ	200 Ω	slope calibration
0 Ω	50 mΩ	2000 Ω	zero calibration
1000 Ω	50 mΩ	2 kΩ	slope calibration
0 mV	2 u	20 mV	zero calibration
19 mV	2 u	20 mV	slope calibration
0 mV	7 u	200 mV	zero calibration
190 mV	7 u	200 mV	slope calibration
0 mV	50 u	2 V	zero calibration
1.9 V	50 u	2 V	slope calibration

Tab.15 Multimeter

For calibration of ranges 2, 10 V and 20 mA cable adapter Option 40 must be used. For calibration of resistance ranges cable adapter Option 60 is necessary. For calibration of voltage ranges 20mV, 200mV, 2V cable adapter Option 80 has to be applied.

Full calibration procedure

Following pages describe procedure of the full calibration.

Required instruments:

Following instruments are required for calibration:

- 8 1/2 digit multimeter type HP3458A or Fluke 8508A, or other type with accuracy 0.001 % on DC voltage
- Resistance shunt 10 m Ω , 100 m Ω Burster 1280, or other type with accuracy 0.01%
- Resistance standard 100 Ω , 1000 Ω Burster 1228, 1229, or other type with accuracy 0.005%
- RLC Agilent/HP 4263A, Agilent/HP4278A, Agilent/E4981A, or other with accuracy 0.1 %
- Counter Agilent/HP 53181A, Agilent/HP 53130, or other with accuracy 0,001 %
- Powermeter 0.02- 0.05 %, Zimmer LG95 or better

HP8903A Distortion analyzer and scope with bandwidth min. 20 MHz are recommended for THD measuring of AC signals.

Calibration procedure

1. Connect the calibrator and the multimeter to the mains and let them switched on for at least three hours in a laboratory at 23 ± 1 °C.
2. Press SETUP display button to call up the setup menu and then CALIB display button to call up the calibration menu.
3. Enter the calibration code and press ENTER (default calibration code is "00000").
4. **DC voltage ranges calibration**
 - a) Connect the voltage input terminals of the multimeter to the Hi - Lo output terminals of the calibrator.
 - b) Select VOLTAGE DC from the calibration menu and confirm by pressing SELECT button. Switch M-142 output terminals ON.
 - c) Follow the instructions provided on the calibrator's display and the DCU table to adjust the calibrator's output in the calibration points.
 - d) To adjust the calibrator's output in the calibration points, press SELECT button and use <, >, \vee , \wedge cursor buttons or potentiometer to adjust output voltage. Confirm correctly set value by pressing WRITE display button. If you want to skip the calibration point whose calibration you have already entered, press SKIP display button.
 - e) Switch output terminals OFF
5. **AC voltage ranges calibration**
 - a) Select VOLTAGE AC from the calibration menu and confirm by pressing SELECT button. Switch M-142 output terminals ON.
 - b) Follow the instructions provided on the calibrator's display and the ACU table to adjust the calibrator's output in the calibration points.

- c) To adjust the calibrator's output in the calibration points, press SELECT button and use <, >, √, ^ cursor buttons or potentiometer to adjust the output voltage. Confirm correctly set value by pressing WRITE display button. If you want to skip the calibration point whose calibration you have already entered, press SKIP display button.
- d) Switch output terminals OFF. Disconnect multimeter and calibrator.

6. DC current ranges calibration

- a) Connect current input terminals of the multimeter to the +I - -I output terminals of the calibrator. Select CURRENT DC from the calibration menu.
- b) Select DC current measurement range on external multimeter. Switch output terminals ON
- c) Follow the instructions provided on the calibrator's display and the DCI table to adjust the calibrator's output in the calibration points.
- d) To adjust the calibrator's output in the calibration points, press SELECT button and use <, >, √, ^ cursor buttons or potentiometer to adjust the output current. Confirm correctly set value by pressing WRITE display button. If you want to skip the calibration point whose calibration you have already entered, press SKIP display button.
- e) Resistance shunt should be used on 2A, 30 A ranges, if standard multimeter does not cover this range.

7. AC current ranges calibration

- a) Select CURRENT AC from the calibration menu. Set the same function on external multimeter.
- b) Follow the instructions provided on the calibrator's display and the ACI table to adjust the calibrator's output in the calibration points.
- c) To adjust the calibrator's output in the calibration points, press SELECT button and use <, >, √, ^ cursor buttons or potentiometer to adjust the output current. Confirm correctly set value by pressing WRITE display button. If you want to skip the calibration point whose calibration you have already entered, press SKIP display button.
- d) Resistance shunt should be used on 2A, 30 A ranges, if standard multimeter does not cover this range.

8. DC power ranges calibration

- a) DC power ranges calibration is performed by calibrating 20 mA, 200 mA, 2 A, 20 A DC current ranges. There is no need to calibrate voltage ranges.
- b) Select POWER DC from the calibration menu.
- c) Connect a standard ammeter to calibrator's output terminals +I - -I.



ATTENTION

Calibrator's Lo and -I terminals are electrically connected.

- d) Follow the instructions provided on the calibrator's display and the POWER DC table to adjust the calibrator's output in the calibration points.
- e) To adjust the calibrator's output in the calibration points, press SELECT button and use <, >, √, ^ cursor buttons or potentiometer to adjust the output voltage. Confirm correctly set value by pressing WRITE display button.
- f) Shunt should be used on 2A, 10 A ranges.

9. AC power ranges calibration

- a) DC power ranges calibration is performed by calibrating 20 mA, 200 mA, 2 A, 20 A AC current ranges. There is no need to calibrate the voltage ranges.
- b) Select POWER DC from the calibration menu.
- c) Connect a standard ammeter to calibrator's output terminals +I - -I
- d) Follow the instructions provided on the calibrator's display and the POWER AC table to adjust the calibrator's output in the calibration points.
- e) To adjust the calibrator's output in the calibration points, press SELECT button and use <, >, √, ^ cursor buttons or potentiometer to adjust the output voltage. Confirm correctly set value by pressing WRITE display button..
- f) Shunt should be used in 2A, 20 A ranges.

10. Resistance ranges calibration

Resistance ranges calibration is performed by both calibration methods, i.e. setting the checked value and measuring this value with the standard instrument, as well as setting the nominal value of the calibrator's measurement range on the external multimeter by adjusting the calibrator's output. If the entry of measured value to the calibrator is required, VALUE METER is displayed at the respective calibration point. The value on the calibrator's display has the same format as the nominal value of the respective calibration point on the display. If, on the other hand, the user is requested to adjust the calibrator's output to set the nominal value of the calibrator's measurement range on the external multimeter, VALUE is displayed at the respective calibration point. The value on the calibrator's display has general format.

- a) The calibrator have to be calibrated using adapter Option 70, in four-wire connection in range bellow 100 kΩ. Connect adapter to the AUXILIARY connector. Select RESISTANCE from the calibration menu
- b) Select four-wire resistance measurement function on the external multimeter. Adjust the zero value of the external multimeter including the cables, if necessary.
- c) Connect all four wires of adapter Option 70 to the input terminals of external multimeter. Use four wire technique. Connect correct terminals and wires.
- d) Measure the resistance in the recommended calibration points using the multimeter and write the values into the calibrator. Use numeric keyboard, potentiometer or cursor buttons to enter the value.
- e) Perform the adjustment for all calibration points as usual. Press WRITE display button to confirm correct values.
- f) Disconnect adapter Option 70 from AUXILIARY connector.
- g) Connect standard multimeter directly to Hi - Lo output terminals. Repeat steps d) to f) for resistance calibration points above 100 kΩ.

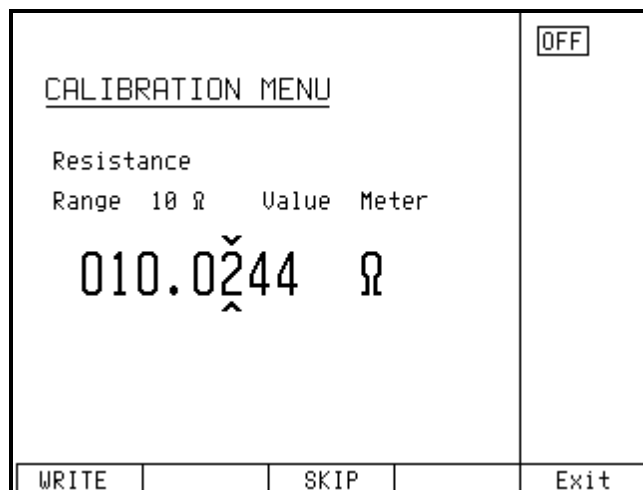

11. Capacitance ranges calibration

Capacitance ranges calibration is performed by both calibration methods, i.e. setting the checked value and measuring this value with the standard instrument, as well as setting the nominal value of the calibrator's measurement range on the external multimeter by adjusting the calibrator's output. If the entry of measured value to the calibrator is required, VALUE METER is displayed at the respective calibration point. The value on the calibrator's display has the same format as the nominal value of the respective calibration point. If, on the other hand, the user is requested to adjust the calibrator's output to set the nominal value of the calibrator's measurement range on the external multimeter, VALUE is displayed at the respective calibration point. The value on the calibrator's display has general format.

- Select CAPACITANCE from the calibration menu. Select GND U OFF and GND I OFF from the setup menu.
- Adjust the values of shorted and open terminals of the external RLC meter, set the frequency used during the measurement (1000 Hz for 1 nF to 10 nF range, 100 Hz for 10 nF to 100 uF ranges). Connect Hi, Hu terminals to calibrator's Lo output and Li, Lu terminals to calibrator's Hi output.
- Measure the capacitance of internal range capacitors using the RLC meter and write the values into the calibrator. The procedure is the same as when calibrating the resistance ranges.
- Perform the adjustment for all calibration points as usual. Press WRITE display button to confirm correct values.

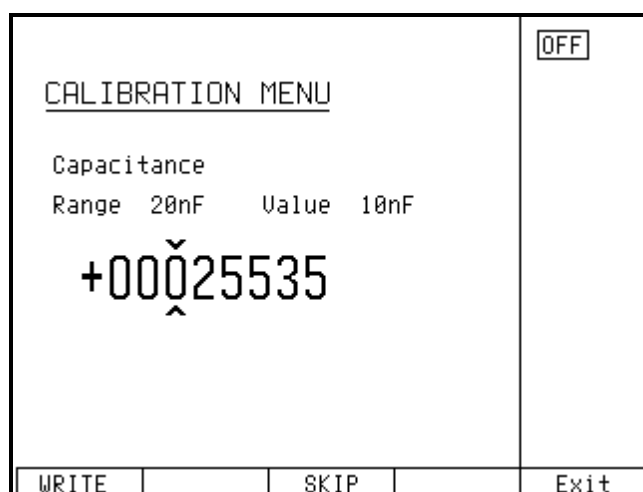

11. Amplitude calibration in frequency mode

- a) Select FREQUENCY in the calibration menu.
- b) Connect the external multimeter with DC voltage measurement range selected to calibrator's Hi - Lo output terminals.
- c) Follow the instructions provided on the calibrator's display and the F table to adjust the calibrator's output in the calibration points. To adjust the calibrator's output in the calibration points, use <, >, ∨, ∧ cursor buttons to adjust the output value. Confirm correctly set value by pressing WRITE display button.
- d) When calibrating the amplitude of the frequency generation function, DC voltage corresponding to the amplitude of output square wave signal is set.

12. Built-in multimeter calibration

Built-in multimeter calibration consists of the calibration of 20 mV, 200 mV, 2V and 10 V voltage ranges, one 20 mA current range and 200 Ω and 2 kΩ resistance ranges.

Cable adapters Option 40 – two-wire adapter, Option 60 – four-wire adapter and Option 80 – two wire adapter are necessary to connect the multimeter.

Due to the fact that the precision of the built-in multimeter is comparable to the precision of the calibrator in resistance, small voltage and current ranges, external calibrator of higher precision class should be used to calibrate the built-in multimeter. If external calibrator is not available, the calibrator can be used to calibrate the built-in multimeter, but it has to be taken into account the fact that the precision of the calibration can be insufficient. An 8 1/2 digit multimeter is recommended for calibration.

- a) 10 V DC voltage range calibration
 - Connect adapter Option 40 to the AUXILIARY connector on the front panel.
 - Select ANALOG INPUT from the calibration menu. Press SELECT display button to select the first calibration point, 0 mV.
 - Make short on adapter Option 40.
 - After the value stabilizes, press WRITE display button to write new calibration value.
 - Connect input voltage terminals of external multimeter to Hi – Lo output terminals of the calibrator. You can use test wires, which are part of basic delivery. Connect Option 40 H input wire of adapter Option 40 to the Hi output or the calibrator and L input wire of adapter Option 40 to the Lo output on the calibrator. If necessary, adjust the zero point of the external multimeter before connecting the cables (internal and external multimeters are in parallel).
 - Press SELECT display button to select 10 V calibration point. Red light is lighting, all terminals on calibrator are automatically ON.
 - “Output = xx.xxxxx V “ is displayed in the bottom part of the display, showing the set value of output voltage. This value can be changed using the potentiometer or cursor button.
 - Adjust the calibrator's output voltage so that the external multimeter shows 10.0000 V
 - After the value stabilizes, press WRITE display button to write new calibration value. If calibration in this point is not required, press SKIP. Terminals of multimeter will switch OFF.
 - Disconnect both the external and built-in multimeter.
- b) 20 mA DC current range calibration

- Leave input terminals of Option 40 adapter OPEN.
- Make short on calibrator output terminals +I - -I.
- Press SELECT display button to select the first calibration point, 0 mA.
- After the value stabilizes, press WRITE display button to write new calibration zero value.
- Disconnect short on +I - -I terminals. Connect L input wire of adapter Option 40 to the -I output on the calibrator, H input wire of adapter to the minus current input on standard multimeter and +I output terminal of the calibrator to the positive current input of standard multimeter. Calibrator current output, input of the internal multimeter and current input of standard multimeter are connected in series. If necessary, adjust the zero point of the external multimeter before calibrating current range.
- Press SELECT display button to select calibration point, 19 mA. Red LED is lit above OUTPUT button.

Note: It can occur, that calibrator beeps and display error message. In this case push the button OUTPUT ON to switch calibrator output manually.

- Adjust the calibrator's output current so that the external multimeter shows 19.0000 mA. After the value stabilizes, press WRITE display button to write new calibration value. Terminals of multimeter will switch OFF.
- Disconnect both the external and built-in multimeter. Disconnect cable adapter Option 40 from the AUXILIARY connector.

c) Resistance range calibration

Calibration of both ranges 100 and 1000 Ω consists of following steps:

- 0 Ω calibration
- resistance range of multimeter calibration

For calibration of resistance ranges external standard 100 Ω and 1000 Ω are required. Connect to the AUXILIARY connector cable adapter Option 60.

0 Ω calibration

- Make short of all four Option 60 input wires.
- Press SELECT display button to select the first calibration point, 0 Ω .
- After the value stabilizes, press WRITE display button to write new calibration value.

100 Ω calibration

- Connect resistance standard 100 Ω to the input terminals. Use four-wire technique.
- Press SELECT display button to select the second calibration point, 100 Ω .
- After the value stabilizes, write calibration value of resistance standard to the lower line and confirm by pressing WRITE.

d) 1000 Ω resistance range calibration

- Make short of all four Option 60 input wires.
- Press SELECT display button to select the first calibration point, 0 Ω .
- After the value stabilizes, press WRITE display button to write new calibration value.

1000 Ω calibration

- Connect resistance standard 1000 Ω to the input terminals. Use four-wire technique.
- Press SELECT display button to select the second calibration point, 1000 Ω .

- After the value stabilizes, write calibration value of resistance standard to the lower line and confirm by pressing WRITE.
- e) 20 mV voltage range calibration
- Connect cable adapter Option 80 to the AUXILIARY connector.
 - Make short of test wires of Option 80 adapter.
 - Press SELECT display button to select the first calibration point of 20 mV range, 0 mV.
 - After the value stabilizes, press WRITE display button to write new calibration value.
 - Connect external standard multimeter set to the mVDC function to the Hi – Lo output terminals. Use test wires from basic delivery. Connect HU test wire of cable adapter to the Hi terminal on the calibrator and LU test wire of cable adapter to the Lo terminal on the calibrator. Both build-in meter and external multimeter are in parallel. If necessary, adjust zero of standard multimeter before calibration.
 - Press SELECT display button to select 19 mV calibration point. Red LED is lit above OUTPUT button.
 - Set such output voltage on the calibrator, that standard multimeter indicates 19.000 mV
 - After the value stabilizes, press WRITE display button to write new calibration value. Terminals of the calibrator will switch OFF automatically.
 - Disconnect input wires of Option 80.
- f) 200 mV voltage range calibration
- Make short of test wires of Option 80 adapter.
 - Press SELECT display button to select the first calibration point of 200 mV range, 0 mV.
 - After the value stabilizes, press WRITE display button to write new calibration value.
 - Connect external standard multimeter set to the mVDC function to the Hi – Lo output terminals. Use test wires from basic delivery. Connect HU test wire of cable adapter to the Hi terminal on the calibrator and LU test wire of cable adapter to the Lo terminal on the calibrator. Both build-in meter and external multimeter are in parallel. If necessary, adjust zero of standard multimeter before calibration.
 - Press SELECT display button to select 190 mV calibration point. Red LED is lit above OUTPUT button.
 - Set such output voltage on the calibrator, that standard multimeter indicates 190.00 mV
 - After the value stabilizes, press WRITE display button to write new calibration value. Terminals of the calibrator will switch OFF automatically.
 - Disconnect input wires of Option 80.
- g) 2000 mV voltage range calibration
- Make short of test wires of Option 80 adapter.
 - Press SELECT display button to select the first calibration point of 2000 mV range, 0 mV.
 - After the value stabilizes, press WRITE display button to write new calibration value.
 - Connect external standard multimeter set to the mVDC function to the Hi – Lo output terminals. Use test wires from basic delivery. Connect HU test wire of cable adapter to the Hi terminal on the calibrator and LU test wire of cable adapter to the Lo terminal on the calibrator. Both build-in meter and external multimeter are in parallel. If necessary, adjust zero of standard multimeter before calibration.

- Press SELECT display button to select 1900 mV calibration point. Red LED is lit above OUTPUT button.
 - Set such output voltage on the calibrator, that standard multimeter indicates 1900.0 mV
 - After the value stabilizes, press WRITE display button to write new calibration value. Terminals of the calibrator will switch OFF automatically.
 - Disconnect input wires of Option 80.
- i) Exit the calibration mode.

AUTOCAL function

To remove the effects of short-term drift and thermal dependency of the simulation, AUTOCAL function can be used. It can only be activated in the calibration mode.

Use of AUTOCAL function influences the zero value of DC voltage generated by the calibrator. Use of the function is recommended only after the calibrator reaches the operating temperature.

Procedure:

- Use a display button to enter the calibration mode. Enter the calibration code and confirm by pressing ENTER.
- Use the cursor buttons or potentiometer to select the AUTOCAL function from the calibration menu. After the function is activated, only one option - OFFSET ACAL - is provided. Press SELECT display button to confirm the option.
- The calibration includes two steps. During the first step, Hi-Lo terminals must be shorted. Use a short cable to connect the terminals. During the second step, the calibrator requests the disconnection of Hi-Lo terminals. Follow the instructions provided on the display:
 - when requested to do so, short calibrator's Hi-Lo terminals. Press NEXT display button.
 - the calibrator performs internal measurement for ca 30 seconds. During this period, progress information is displayed in the bottom part of the display.
 - after the measurement completes, the calibrator requests the disconnection of Hi-Lo terminals. Disconnect the cable and confirm by pressing NEXT display button.
 - the calibrator performs internal measurement of voltage ranges for ca 8 minutes. During this period, progress information is displayed in the bottom part of the display.
 - after the measurement completes, the calibrator returns to the calibration mode.
 - press EXIT display button to return to normal state.
- Do not connect any terminals during the calibration procedure, with the exception of requested short of Hi-Lo terminals.

Error messages

If an error occurs during the calibrator's operation or control, error message is displayed on the display. Errors can be caused by:

- incorrect control using the front panel, i.e. attempts to force a prohibited mode, e.g. setting an out-of-range value, overloading of output terminals etc.,
- fault of the calibrator, e.g. internal communication error during the communication between individual functional blocks,
- incorrect control using the GPIB or RS-232 bus.

Below you can see a sample error message which appears when too large value is attempted to set up. All error messages are displayed in the center of the display.

OUTPUT				OFF
05.00000 U DC				Local GndU Off
Error 40 Value too large !				Accuracy 0.0050%
INPUT				mA DC
x 10	: 10		+/-	Setup

The following table lists all error messages, their meaning and simple troubleshooting.

No error	label	description	troubleshooting
01	Overload 2V !	2V range overloaded	Output current is too high. Increase load resistance.
02	Overload 20V !	20 V range overloaded	Output current is too high. Increase load resistance.
03	Overload 200V !	200, 1000 V ranges overloaded	Output current is too high. Increase load resistance.
04	Overload I output !	Current output overloaded	Voltage on the load is too high. Decrease load resistance.
05	High temperature !	Too high internal temperature	Output stages are overloaded. Do not use ranges 200V, 1000V or 20 A for at least 10 minutes. Check if the ventilation holes are free.
06	Overload RC !	RC simulator overloaded	Test current is too high. Use lower range of tested Ohmmeter.
07	FBK error !	Internal error	Turn off the calibrator and turn on it again.
08	OUTPUT must be in OFF state !	Cable adapter tried to be exchanged while output terminals was ON	Switch off output terminals with button OUTPUT, change the adapter, and switch output terminals on.
10	Interface error !	GPIB communication error	Wrong data format on GPIB.
11	Bad command !	Bad command of GPIB	Not known command on GPIB.
12	Bad communication !	GPIB communication error	Listener not connected to the GPIB. Check correct connection of GPIB cable.
13	Over range !	Overcrossing the range via GPIB	Value out of range was set via GPIB. Set correct value.
20	Bad calib. code !	Bad calibration code	Wrong calibration code was entered, calibration cannot start. Enter correct calibration code.
21	Time warm up !	Attempt to start calibration before warm up	Attempt to start calibration before 60 minutes warm up period. Let the calibrator turned on for at least 60 minutes.
24	Cable adapter must be off !	Adapter isn't allowed for autocalibration	Use another cable adapter or perform autocalibration procedure without cable adapter.
25	Use cable adapter !	Attempt to start calibration without cable adapter.	Calibration of resistance ranges can be performed with adapter Option 70. Calibration of internal multimeter can be performed with cable adapters Option 40 and Option 60.
30	Internal RxD timeout !	Internal error	Internal error of the calibrator. Turn the calibrator off and after 5 s turn on. If the error will appear again, contact manufacturer.
31	Internal communication !	Internal error	Internal error of the calibrator. Turn the calibrator off and after 5 s turn on. If the error will appear again, contact manufacturer.
37	Calibrator is not ready !	Internal error	Internal error of the calibrator. Turn the calibrator off and after 5 s turn on. If the error will appear again, contact manufacturer.
40	Value too large !	Maximum value is out of limit	Attempt to set value over possible range. Set correct value.
41	Value too small !	Minimum value is out of limit	Attempt to set value under possible range. Set correct value.
42	Deviation too large !	Deviation is too high	Set deviation is out of limit -30% to +30%. Set correct value.
44	Unable +/- !	Change of polarity is not allowed	Attempt to change polarity, where it is not allowed.. Concerned modes F, P-E, R-C, ACV, ACI.
45	Unable - polarity !	Negative polarity is not allowed.	Attempt to set negative polarity, where it is not allowed.. Concerned modes F, P-E, R-C, ACV, ACI.
46	Unable DC/AC !	DC/AC conversion is not possible	Attempt to change parameter AC/DC where it is nonsense or where it is not allowed.
47	Current timeout !	Time limit for current over 10 A exceeded	Long-term loading current terminals with output current over A.
48	Not allowed on AUX output !	Function cannot be used on output AUXILIARY	Do not use this setting in combination with connected cable adapter.

Tab. 16 Error messages

Functional description of the calibrator

Basic blocks

Basic functional blocks are:

- front panel keyboard
- LCD display
- output terminals
- output voltage amplifier 200 V
- output voltage amplifier 20 A
- main board
- voltage amplifier 2 V
- voltage amplifier 20 V
- DC reference voltage with DAC
- generator
- feedback circuits
- phase shift circuits
- current ranges generator
- multimeter
- power line transformer
- power supply board
- interface GPIB and RS232

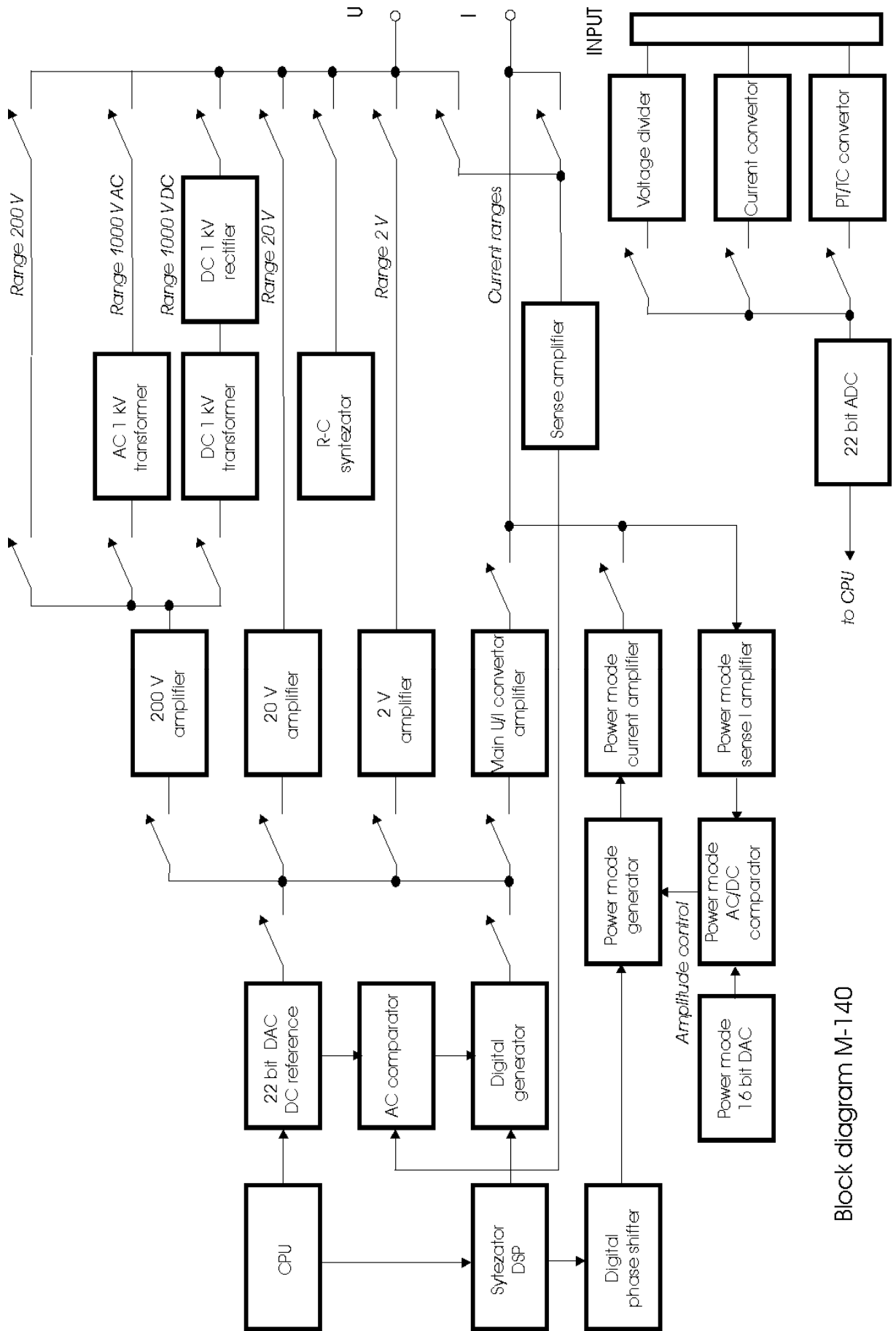

Block diagram M-140

2, 20 V DC voltage ranges

The functional scheme is shown in the picture below:

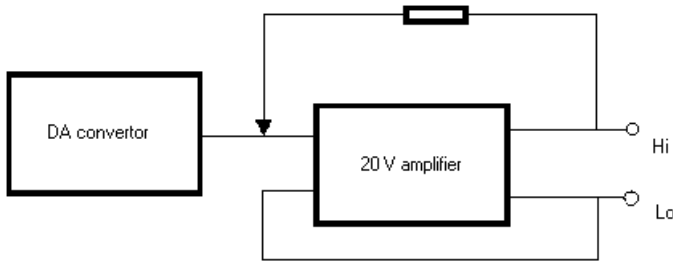

There is a DC reference voltage source integrated within the 22bit measurement converter. Its output is fed to the output stage for 2 and 20 V range. Output voltage present at Hi and Lo terminals is sensed by sensing wires. Feedback eliminates the influence of amplifier's output impedance and of the resistance of wires within the calibrator.

200 V DC voltage range

The block diagram functional scheme is shown in the picture below.

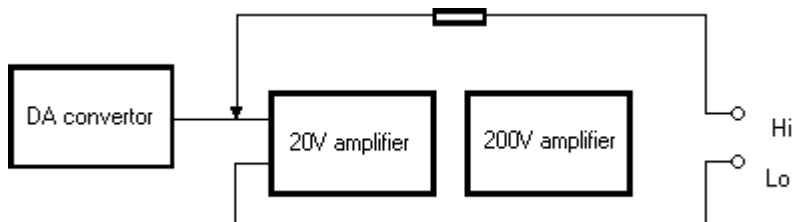

The scheme is similar to 2 and 20 V ranges. A 240 V power amplifier with electronic fuses is connected to the output of 20 V amplifier.

2 to 200 V AC voltage ranges

The functional scheme is shown in the picture below:

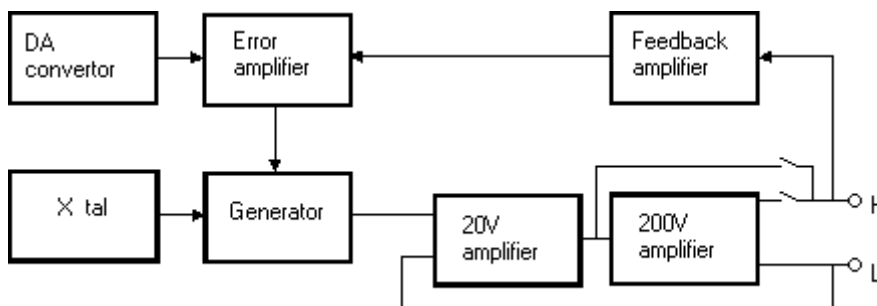

The calibrator's built-in generator generates a sine wave with voltage-controlled amplitude. The frequency is derived from microprocessor control circuit's crystal oscillator. The signal is fed to 20 V or 200 V amplifier and then to output terminals. Feedback circuits sense the voltage present at the output terminals, normalize its value and detects it. This results in a signal corresponding to average value of the output voltage. This signal is further filtered and compared to the set value of output voltage. The error value controls the amplitude of the generator's output.

20mV and 200 mV voltage ranges

20 mV and 200 mV voltage ranges are derived from 2 and 20 V voltage ranges.

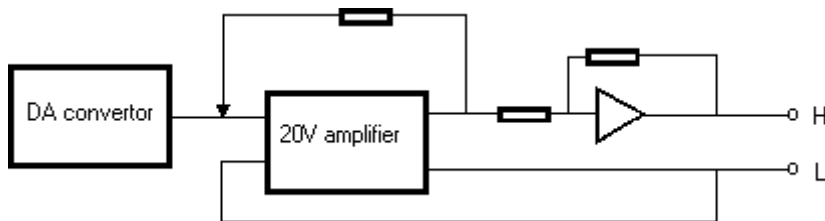

The output of the amplifier is fed to an inverting attenuator with 1:100 nominal division ratio. The signal is then led to the output terminals, sensed via local feedback. This connection allows to load the calibrator output with output current of several mA without losing accuracy.

1000 V AC, DC voltage range

The highest voltage range of the calibrator uses 200 V amplifier. It is connected to a pair of transformers with ca 1:6 transformation ratio.

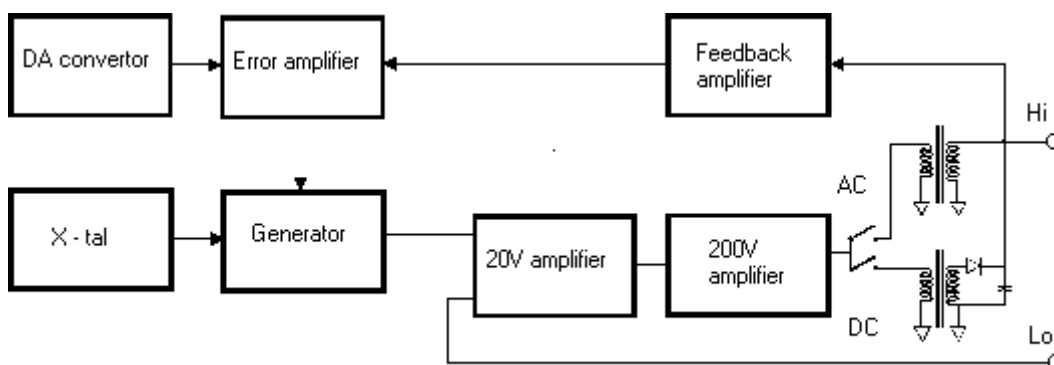

In 1000 V AC mode, the output of 200 V amplifier is transformed and led to the output terminals. The output voltage is sensed, rectified and compared to reference DC voltage provided by the DA converter. error value controls the amplitude of the generator's output so that there is correct voltage at the output terminals.

In 1000 V DC mode, 12 kHz signal is transformed, rectified, filtered and led to the output terminals. The output voltage is sensed equally to 1000 V AC mode.

Current converter

The current converter and current amplifier form a separate design block based on a transconductivity converter with 10^{-5} S nominal conversion ratio.

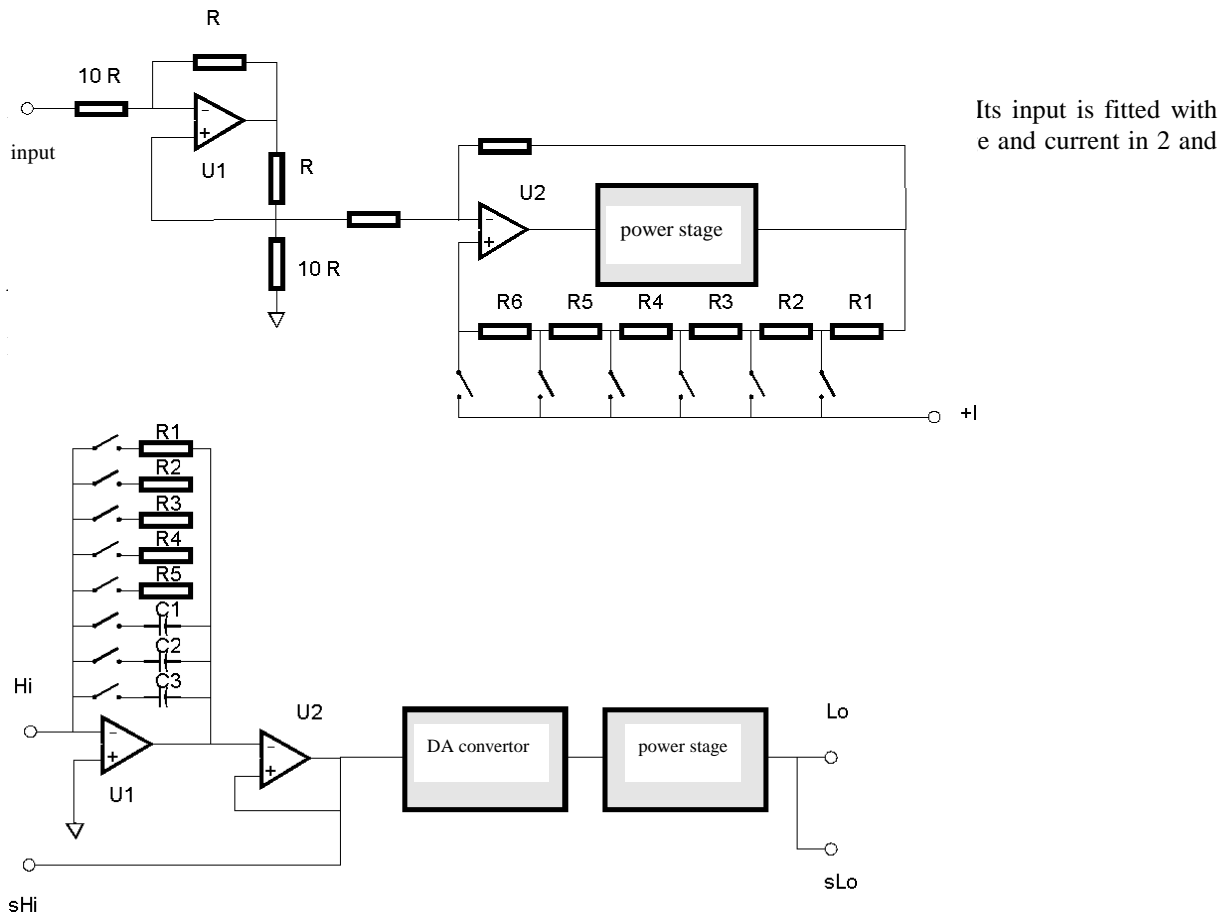

Hi and Lo are calibrator’s output terminals. The stage including U1 operating amplifier converts voltage to current. U2 is a separation amplifier. R1 to R5 and C1 to C3 are range impedance. DA converter has 0 to +1 and 0 to -1 conversion ratio and allows the simulation of resistance and capacitance values different from the range impedances. The output stage increases the permitted current load of the output.



ATTENTION

The simulator’s output voltage (Hi - Lo terminals) is limited to 8 Vpk.

Frequency synthesizer

Frequency synthesis circuitry allows fine setting of frequency in the whole calibrator's range. Frequency synthesis uses DSP circuits with basic frequency 20 MHz.

Power and energy mode

In the power/energy mode, the calibrator supplies the set voltage to Hi-Lo terminals and the set current through +I – I terminals. Both signals have defined phase shift according to the set power factor, if AC mode is set.

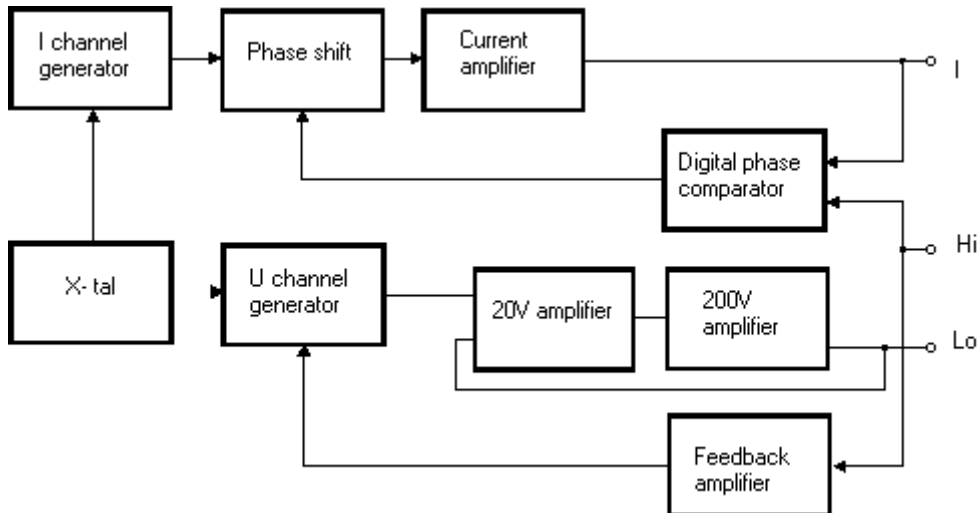

Output voltage is obtained from 200 V AC voltage range. Output current is obtained from 2 or 20 A current range. The output current generator is independent of the output voltage generator and synchronized by the microprocessor's crystal oscillator. There is a phase shift between the signals of the output current generator and output voltage generator according to the set power factor. The phase of output current and voltage is compared by a phase comparator and compared to a reference value representing the set power factor; the output drives a voltage-controlled phase shift element, which controls the phase of output current.

Calibrator's maintenance

The multifunction calibrator is electronic instrument with microprocessor control. All blocks which are heavily loaded during the operation are cooled by a fan.

Rules for correct operation

Especially the following rules should be adhered to guarantee correct operation of the calibrator:

- *The calibrator can only be switched on and off by pressing the mains switch located at the rear panel.*
- *Do not connect the calibrator to other voltage than set by the voltage selector.*
- *Do not block the vent openings located at the rear panel and bottom panel.*
- *The calibrator must not be operated in dusty environment. It was designed to be used in a laboratory.*
- *No liquid or small objects can be permitted to enter the calibrator through the vent openings..*
- *Do not switch the calibrator outside its operating temperature range.*
- *Connect the instruments to be calibrated to proper output terminals. There is no way of protecting the calibrator from the damage caused by some improper connections.*
- *Do not damage the output terminals by plugging in "bananas" thicker than the terminals were designed for.*
- *Whenever possible, use the setup menu to ground Lo output terminal (GND U ON setup function).*
- *Do not overload the power stages by leaving the calibrator switched on with the load connected for a long time, especially on 30 A current range and 200V and 1000 V voltage ranges.*
- *If the instruments to be calibrated are not connected to calibrator's output terminals using original cables, ensure that cables suitable for the calibration voltage and current are used. Maximum output voltage can reach 1000 V AC and the maximum output current can reach 30 A AC.*

Regular maintenance

The calibrator does not require any special maintenance of electrical or mechanical parts. If it gets dirty, the case and the display can be cleaned by a wool rag moistened with alcohol.

The calibrator should be calibrated in the recommended 12-month intervals. A calibration center should perform the calibration.

What to do in case of failure

If an **obvious failure** occurs during the operation (e.g. the display is not lit, the fan is not turning), the calibrator must be switched off immediately. First, check the fuse located in the power cord receptacle. Procedure is following:

- Remove the end of power cord from the mains connector at the rear panel.
- Insert the blade of a flat screwdriver into the opening cut in the mains voltage selector and pry out the fuse holder.

- Remove the fuse. Replace it with new fuse of the same rating if the fuse was broken.
- Replace the fuse holder, reconnect the power cord and switch on the calibrator. If the problem persists, contact the manufacturer.

If an obvious fault is evidenced, e.g. a measurement range or an operating mode is not functional, the user cannot correct the fault. Contact the manufacturer.

Hidden faults can cause different symptoms and be caused by different causes. Usually, they cause instability of some parameter. Hidden defects can be caused by unacceptable distortion, degraded insulation etc. In this case contact the manufacturer.

Sometimes it seems that the calibrator has hidden defect, when the rules for correct operation are not adhered to. In this case, the fault is caused by the operator. Most frequent cases of false “hidden defects”:

- mains voltage out of tolerance limits or unstable
- wrong grounding of the measurement circuit (bad connection of the ground terminal of the mains outlet, or several ground connection when grounding loops are formed)
- proximity to sources of intensive influence, whose products are spread through the mains or propagated by the electromagnetic field
- strong electrostatic or electromagnetic field which can cause major instability during calibration using higher impedance.

Verification test

Procedure recommended for verifying parameters of the calibrator is described in this chapter. During tests it is not necessary access to the interior of the instrument.

Required equipment

Following instruments are required for performance verification test:

- 8 1/2 digit multimeter type HP3458A or Fluke 8508A, or other type with accuracy 0.001 % on DC voltage
- resistance shunt 10 m Ω , 100 m Ω Burster 1280, or other type with accuracy 0.01%
- RLC meter BM 595, HP 4263A, HP4278A, ESI 2150, or other with accuracy 0.1 %
- counter HP 53181A, HO 53130, BM 642 or other with accuracy 0,001 %
- powermeter 0.02- 0.05 % like Zimmer LMG95, Yokogawa
- resistance standard 100 Ohm, 1000 Ohm with accuracy 0.005%

HP8903A Distortion analyzer and scope with bandwidth min. 20 MHz are recommended for THD measuring of AC signals.

Configuration of the calibrator

Calibrator should be tested directly from the front panel terminals and without use of terminal adapter 140-01. For build-in multimeter testing cable adapters Option 40 and Option 60 are recommended. To suppress influence of noise or interference with power line frequency in measuring circuit it is recommended following setting of the calibrator (in SETUP MENU):

- **Current Coil** **OFF**
- **GND U** **ON (in capacitance test OFF)**
- **GND I** **ON (in capacitance test OFF)**

Note: It is recommended to ground only the voltage channel GND U ON, GND I OFF, for all ranges except the generation of power or energy. If the meter to be calibrated has Lo terminal grounded, it is recommended to un-ground both outputs of the calibrator, GND U OFF, GND I OFF to exclude ground loops.

If it is grounded neither calibrator nor standard meter, higher level can occur on the output terminals.

In general, when calibrator is connected to the standard meter, ground loops can be arise through power line connection. Ground loops can result apparently worse noise, short term stability or non-harmonic distortion of output signal. If necessary use toroidal chokes to suppress this products.

- **Meter average** **05**

In all other items in SETUP MENU the setting of parameters don't influence accuracy of the calibrator.

Use sin waveform of the output signal on all AC tests.

Performance verification may be performed after warm-up period i.e. 1 hour after switching on. Calibrator have to be in temperature stabilize condition at minimum 8 hours before performance verification test is started.

Basic steps of the performance verification test

Verification procedure consists of following steps:

- **20 V DC voltage** test with linearity check
- **DC voltage** internal ranges 20 mV, 200 mV, 2 V, 240 V, 1000 V test
- **20 V AC voltage** test with linearity check
- **AC voltage** internal ranges 20 mV, 200 mV, 2 V, 20V, 240 V, 1000 V test
- **200 mA DC current** test with linearity check
- **DC current** internal ranges 200 uA, 2 mA, 20 mA test
- **AC current** internal ranges 200 uA, 2 mA, 20 mA, 200 mA test
- **AC/DC high current** ranges 2 A, 30 A test
- **AC/DC power** 4800VA (AC power with PF 0, +0.5, -0.5) test
- **Resistance** test in points 10, 100, 1k, 10k, 100k, 1M, 10M, 50M, 500M Ohm on DC
- **Capacitance** test in points 1n, 10n, 100n, 1u, 10u, 50u F on frequency 1000 Hz
- **Frequency** nominal value 1 kHz test
- **Multimeter** internal ranges 20 mVDC, 200 mVDC, 2 VDC, 10VDC, 25mADC, 200 Ohm, 2 kOhm, frequency 1 kHz test
- **Distortion** checking of AC voltage, range 20 V.

Procedure

Following part describes procedure of performance verification test. Recommended measuring points are the same as the points in table of limits (see tables below).

1. Connect the calibrator to the mains and let them switched on for at least one hour in a laboratory at 23 ± 1 °C.
2. Perform ACAL procedure (see chapter Calibration mode).
3. Connect voltage input of the standard multimeter to the voltage output terminals of the calibrator. Set appropriate parameters on the standard multimeter to achieve its best accuracy.
4. Perform 20 VDC linearity, DC voltage, 20 VAC linearity, AC voltage tests according to the tables I, II, III, IV. Deviations should not exceed specified limits.
5. Connect current input of standard multimeter to the current output terminals of the calibrator. Set appropriate parameters on the standard multimeter to meet its best accuracy.
6. Perform 200 mADC linearity, DC current, AC current tests according to the tables V, VI, VII. Deviations should not exceed specified limits.
7. Connect current output terminals of the calibrator to the current terminals of resistance shunt 100 mOhm. Connect voltage input of standard multimeter to the voltage terminals of the resistance shunt. Set range 100 (200)mV on standard multimeter.
8. Perform AC/DC high current test on range 2 A according to the table VIII. Deviation should not exceed specified limit.
9. Connect current output terminals of the calibrator to the current terminals of resistance shunt 10 mOhm. Connect voltage input of standard multimeter to the voltage terminals of the resistance shunt. Set range 100 (200)mV on standard multimeter.

10. Perform AC/DC high current test on range 30 A according to the table VIII. Deviation should not exceed specified limit.
11. Connect standard powermeter to the appropriate output and current terminals of the calibrator.
12. Perform AC/DC power test according to the table IX. Deviations should not exceed specified limits.
13. Connect voltage terminals of the calibrator to the Hi/Lo and Sense H/L terminals respectively of the standard multimeter. Set resistance mode on multimeter and calibrator as well. Use four-wire technique for connection of multimeter for testing on nominal values below 10 kOhm. Use autozero function of standard multimeter to eliminate thermoelectric voltages and residual resistances of multimeter and cables before measuring.
14. Connect adapter Option 70 to the AUXILIARY connector. Perform resistance test according to the table X. Deviations should not exceed specified limits.
15. Connect voltage terminals of the calibrator to the RCL meter. Switch GND U and GND I OFF in SETUP MENU (In common RCL meters measuring circuit must not be grounded). Connect source terminal of RCL meter to the Lo output terminal of the calibrator.
16. Perform capacitance test according to the table XI. Deviations should not exceed specified limits.
17. Connect output voltage terminals of the calibrator to the counter. Set output voltage 1 VAC, frequency 1 kHz.
18. Perform frequency test according to the table XII. Deviation should not exceed specified limit.
19. Connect Option 40 cable adapter to the auxiliary connector on the front panel. Connect Lo banana of the adapter to the Lo output terminal on the calibrator. Connect Hi banana of the adapter to the Hi output terminal on the calibrator. Set appropriate value of frequency and DC voltage range 20V on the calibrator (frequency and 10 V DC range on build in meter) according to the table XIII.
20. Perform multimeter test in points FREQUENCY 1000Hz and 10 VDCV. Deviations should not exceed limits in the tables below.

Note : Because accuracy of calibrator output is not accurate enough in all points, use external standard counter (frequency) or multimeter (DC voltage) connected in parallel to the output terminals to obtain exact value on the output.
21. Connect Option 40 cable adapter to the +I, -I output terminals of the calibrator. Set appropriate value of output DC current.
22. Perform multimeter test on range 25 mA DC, i.e. point 19 mA DC (see table of limits) according to the table XIII. Deviation should not exceed specified limit.
23. Connect Option 80 cable adapter to the auxiliary connector on the front panel. Set in SETUP MENU of build-in meter function DC voltage, range 2V. Connect together Hu and Lu terminals (banana) of the adapter to make short and use ZERO function of the meter to reset zero point of the meter.
24. Connect terminal Hu of the adapter with output terminal Hi on calibrator. Connect terminal Lu of the adapter with output terminal Li on the calibrator.
25. Set appropriate values of DC voltage on the calibrator according to the table XIII and perform test of meter DC voltage ranges 20mV, 200mV and 2V. Deviation should not exceed specified limit.

Note : Because accuracy of calibrator output is not accurate enough in all points, use external standard multimeter connected in parallel to the output terminals to obtain exact value of DC voltage on the output terminals.
26. Connect Option 60 to the calibrator auxiliary connector. Set resistance function in SETUP MENU of built-in meter. Make four-wire short on the Option 60 banana terminals. Use ZERO function of the built-in meter to exclude parameters of the adapter. Connect standard resistor 100 Ohm to the adapter. Use four-terminal technique.
27. Perform multimeter test on resistance range 200 Ohm according to the table XIII. Deviation should not exceed specified limit.

28. Use the same procedure to test resistance range 2000 Ohm.
29. Disconnect cable adapter Option 60 and connect distortion meter to the voltage output terminals of the calibrator. Set output voltage 10 VAC, frequency 1000 Hz and sin waveform.
30. Check harmonic distortion of output signal. It should not exceed 0.05%.

If calibrator is out of limits is in some points of this test, appropriate function and range should be recalibrated. It is not necessary to recalibrate all functions, but only this one, which does not meet specification. See chapter Calibration mode, where recalibration procedure is described.

Tables of limits**20 V DC Basic range with linearity test**

Function	Range	Value (V)	Frequency (Hz)	Deviation allowed(μ V)
V-DC	20.0 V	2.0	DC	70
V-DC	20.0 V	4.0	DC	90
V-DC	20.0 V	6.0	DC	110
V-DC	20.0 V	8.0	DC	130
V-DC	20.0 V	10.0	DC	150
V-DC	20.0 V	12.0	DC	170
V-DC	20.0 V	14.0	DC	190
V-DC	20.0 V	16.0	DC	210
V-DC	20.0 V	18.0	DC	230
V-DC	20.0 V	19.0	DC	240
V-DC	20.0 V	-2.0	DC	70
V-DC	20.0 V	-4.0	DC	90
V-DC	20.0 V	-6.0	DC	110
V-DC	20.0 V	-8.0	DC	130
V-DC	20.0 V	-10.0	DC	150
V-DC	20.0 V	-12.0	DC	170
V-DC	20.0 V	-14.0	DC	190
V-DC	20.0 V	-16.0	DC	210
V-DC	20.0 V	-18.0	DC	230
V-DC	20.0 V	-19.0	DC	240

Table I

DC voltage test

Function	Range	Value (V)	Frequency (Hz)	Deviation allowed(V)
V-DC	2.0 V	1.9	DC	33 μ
V-DC	2.0 V	-1.9	DC	33 μ
V-DC	240.0 V	190.0	DC	3.335 m
V-DC	240.0 V	240.0	DC	4.100 m
V-DC	240.0 V	-190.0	DC	3.335 m
V-DC	240.0 V	-240.0	DC	4.100 m
V-DC	1000.0 V	1000.0	DC	55 m
V-DC	1000.0 V	-1000.0	DC	55 m

Table II

20 V AC Basic range with linearity test

Function	Range	Value (V)	Frequency (Hz)	Deviation allowed(%value)
V-AC	20.0 V	2.0	1000	1.36 m
V-AC	20.0 V	4.0	1000	1.72 m
V-AC	20.0 V	6.0	1000	2.08 m
V-AC	20.0 V	8.0	1000	2.44 m
V-AC	20.0 V	10.0	1000	2.80 m
V-AC	20.0 V	12.0	1000	3.16 m
V-AC	20.0 V	14.0	1000	3.52 m
V-AC	20.0 V	16.0	1000	3.88 m
V-AC	20.0 V	18.0	1000	4.24 m
V-AC	20.0 V	19.0	1000	4.42 m

Table III

AC voltage test

Function	Range	Value (V)	Frequency (Hz)	Deviation allowed(V)
V-AC	20 mV	0.019	1000	68 μ
V-AC	200 mV	0.19	1000	270 μ
V-AC	2.0 V	1.9	1000	442 μ
V-AC	20.0 V	19.0	50	4.42 m
V-AC	20.0 V	19.0	120	4.42 m
V-AC	20.0 V	19.0	10000	4.42 m
V-AC	20.0 V	19.0	20000	15.5 m
V-AC	20.0 V	19.0	50000	15.5 m
V-AC	240.0 V	190.0	1000	44.2 m
V-AC	1000 V	750.0	120	500.0 m

Table IV

200 mA DC Basic range with linearity test

Function	Range	Value (A)	Frequency (Hz)	Deviation allowed(μ A)
A-DC	200.0 mA	0.02	DC	8
A-DC	200.0 mA	0.04	DC	10
A-DC	200.0 mA	0.06	DC	12
A-DC	200.0 mA	0.08	DC	14
A-DC	200.0 mA	0.10	DC	16
A-DC	200.0 mA	0.12	DC	18
A-DC	200.0 mA	0.14	DC	20
A-DC	200.0 mA	0.16	DC	22
A-DC	200.0 mA	0.18	DC	24
A-DC	200.0 mA	0.19	DC	25
A-DC	200.0 mA	-0.02	DC	8
A-DC	200.0 mA	-0.04	DC	10
A-DC	200.0 mA	-0.06	DC	12
A-DC	200.0 mA	-0.08	DC	14
A-DC	200.0 mA	-0.10	DC	16
A-DC	200.0 mA	-0.12	DC	18
A-DC	200.0 mA	-0.14	DC	20
A-DC	200.0 mA	-0.16	DC	22
A-DC	200.0 mA	-0.18	DC	24
A-DC	200.0 mA	-0.19	DC	25

Table V

DC current test

Function	Range	Value (A)	Frequency (Hz)	Deviation allowed(A)
A-DC	200.0 μ A	0.00019	DC	0.115 μ
A-DC	200.0 μ A	-0.00019	DC	0.115 μ
A-DC	2.0 mA	0.0019	DC	0.430 μ
A-DC	2.0 mA	-0.0019	DC	0.430 μ
A-DC	20.0 mA	0.019	DC	2.5 μ
A-DC	20.0 mA	-0.019	DC	2.5 μ

Table VI

AC current test

Function	Range	Value (A)	Frequency (Hz)	Deviation allowed(A)
A-AC	200.0 uA	0.00019	60	0.305 μ
A-AC	2.0 mA	0.0019	60	1.53 μ
A-AC	20.0 mA	0.019	60	10.5 μ
A-AC	20.0 mA	0.019	120	10.5 μ
A-AC	20.0 mA	0.019	1000	10.5 μ
A-AC	20.0 mA	0.019	10000	109 μ
A-AC	200.0 mA	0.19	60	105 μ

Table VII

AC/DC high current test

Function	Range	Value (A)	Frequency (Hz)	Deviation allowed(%value)
A-DC	2.0 A	1.0	DC	250 μ
A-DC	2.0 A	-1.0	DC	250 μ
A-AC	2.0 A	1.0	60	600 μ
A-DC	30.0 A	10.0	DC	4 m
A-DC	30.0 A	-10.0	DC	4 m
A-AC	30.0 A	10.0	60	16 m
A-DC	30.0 A	30.0	DC	17 m
A-DC	30.0 A	-30.0	DC	17 m
A-AC	30.0 A	30.0	60	45 m

Table VIII

AC/DC power test

Function	Range	Value (VA)	Frequency (Hz)	Deviation allowed(VA)
P 1	480W	480	60	0.336
P 0,5LA	480W	240	60	1.104
P 0,5LE	480W	240	60	1.104
P 1	2400W	2400	60	3.36
P 0,5LA	2400W	1200	60	9.24
P 0,5LE	2400W	1200	60	9.24

Table IX

Voltage = 240V

Resistance test

Function	Range	Value (Ohm)	Frequency (Hz)	Deviation allowed(Ω)
O-4W	100.0 Ohm	10.0	DC	6 m
O-4W	100.0 Ohm	100.0	DC	15 m
O-4W	1000 Ohm	1000.0	DC	100 m
O-4W	10k Ohm	10000.0000	DC	1
O-4W	100k Ohm	100000.0000	DC	10
O-4W	1M Ohm	1.000000e+6	DC	100
O-4W	10M Ohm	1.000000e+7	DC	5 k
O-4W	50M Ohm	5.000000e+7	DC	100 k
O-4W	500M Ohm	5.000000e+8	DC	2.5 M

Table X

Capacitance test

Function	Range	Value (F)	Frequency (Hz)	Deviation allowed(F)
CAP	1 nF	1.000000e-09	1000	20 p
CAP	10 nF	1.000000e-8	1000	50 p
CAP	100 nF	1.000000e-7	1000	500 p
CAP	1 uF	1.000000e-6	500	10 n
CAP	10 uF	1.000000e-5	120	150 n
CAP	100 uF	1.000000e-4	120	2 μ

Table XI

Frequency test

Function	Range	Value (Hz)	Frequency (Hz)	Deviation allowed(Hz)
FREQ	1 kHz	1000.0		50 m

Table XII

Multimeter test

Function	Range	Value (Hz)	Frequency (Hz)	Deviation allowed
FREQ	1 kHz	1000.0 Hz	DC	50 mHz
V-DC	10 V	10.0 V	DC	1.3 mV
V-DC	10 V	-10.0 V	DC	1.3 mV
A-DC	25 mA	0.020 A	DC	3.3 μ A
A-DC	25 mA	-0.020 A	DC	3.3 μ A
V-DC	20 mV	0.019 V	DC	11 μ V
V-DC	20 mV	-0.019 V	DC	11 μ V
V-DC	200 mV	0.19 V	DC	45 μ V
V-DC	200 mV	-0.19 V	DC	45 μ V
V-DC	2 V	1.9 V	DC	387 μ A
V-DC	2 V	-1.9 V	DC	387 μ A
O-4W	200 Ohm	100.0 Ohm	DC	30 m Ω
O-4W	2 kOhm	1000.0 Ohm	DC	210 m Ω

Table XIII

System control

The calibrator includes standardized IEEE-488 bus and RS232 serial line. System connectors are located at the rear panel. For the remote control to work properly, bus parameters must be set in the system menu. For IEEE-488 bus, address is important (0 to 30 setting range). For RS232 bus, communication speed can be set (150 to 19200 Bd) and software handshake XON/XOFF can be set. The calibrator can be only controlled by one interface at a time. It is therefore necessary to select one of the interfaces (GPIB/RS232) using the system menu.

IEEE-488 bus properties

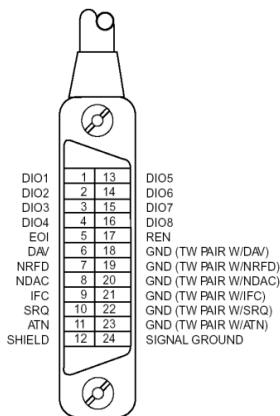

The instrument performs the following functions based on GPIB bus commands:

SH1, AH1, T5, L3, RLI, DC1, SRI

The instrument also recognizes the following general commands:

- DCL Device Clear
- SDC Selected Device Clear
- EOI End or Identify Message Terminator
- GTL Go To Local
- LLO Local Lock Out
- SPD Serial Poll Disable
- SPE Serial Poll Enable

RS232 bus properties

To transfer the data using RS232 bus, 8N1 data format is used, i.e. each data word includes 8 bits, no parity and one stop bit. The communication speed can be set using the system menu. Available values: 150, 300, 600, 1200, 2400, 4800, 9600 and 19200 Bd. Software handshake (communication control) XON/XOFF can be set to control the transfer of the data through the bus.

RS-232 connector layout

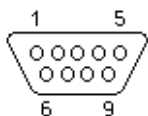

Pin	Label	Direction	Note
2	TXD	output	transmitter
3	RXD	input	receiver
5	GND	-	ground

9-pin connector D-SUB FEMALE

Cable between the calibrator and PC (configuration 1:1)

PC	D-Sub 1	D-Sub 2	M-142
Receiver	2	2	Transmitter
Transmitter	3	3	Receiver
Ground	5	5	Ground

Tab. 17 RS232 connector description

Command syntax

The commands described in this chapter can be issued through both buses (GPIB and RS232).

All commands listed in this chapter are explained in two columns:

KEYWORD and PARAMETERS.

KEYWORD column includes the name of the command. Each command includes one or more keywords. If a keyword is in brackets ([]), it is not mandatory. Non-mandatory commands are used only to achieve compatibility with language standard SCPI.

Capitals designate the abbreviated form of the commands; extended form is written in lowercase.

Command parameters are in brackets (<>); each parameter is separated using a comma. Parameters in brackets ([]) are not mandatory. Line (|) means “or” and is used to separate several alternative parameters.

Semicolon ‘;’ is used to separate more commands written on one line.

E.g. VOLT 2.5 ; OUTP ON

Note:

Each command must end in <cr> or <lf>. Both codes <crlf> can be used at the same time. The calibrator performs all commands written on one line of the program after it receives <cr>, <lf> or <crlf> code. Without this code, the program line is ignored.

Description of abbreviations

<DNPD> = Decimal Numeric Program Data, this format is used to express decimal number with or without the exponent.

<CPD> = Character Program Data. Usually, it represents a group of alternative character parameters. E.g. { ON | OFF | 0 | 1 }.

? = A flag indicating a request for the value of the parameter specified by the command. No other parameter than the question mark can be used.

(?) = A flag indicating a request for the parameter specified by the command. This command permits a value to be set as well as requested.

<cr> = carriage return. ASCII code 13. This code executes the program line.

<lf> = line feed. ASCII code 10. This code executes the program line.

OUTPut subsystem

This subsystem allows to control the output terminals of M142 calibrator, to activate the four-wire output or to switch the calibrator to x50 current coil (option 140-50).

Keyword	Parameters
OUTPut	
[:STATe] (?)	<CPD> { ON OFF 0 1 }
: ISELection (?)	<CPD> { HIGHi HI50turn }

OUTP [:STAT] (?) <CPD> { ON | OFF | 0 | 1 }

This command activates or deactivates the output of M142 calibrator.

- ON or 1 - activates the output

- OFF or 0 - deactivates the output

If query is sent, M142 returns ON if the output is active or OFF if it is inactive

Example: OUTP 1 <cr> - activates the output
 OUTP ? <cr> - the calibrator returns ON or OFF

OUTP :ISEL (?) <CPD> { HIGH | HI50 }

This command activates or deactivates the 1000A current range (using a 50-turn coil).

- HIGH - deactivates the 50-turn coil
- HI50 - activates the 50-turn coil (up to 1000A range)

If query is sent, M142 returns HIGH if the 50-turn coil is deactivated or HI50 if it is activated.

Example: OUTP :ISEL HI50 <cr> activates the 50-turn coil
 OUTP :ISEL ? <cr> the calibrator returns HIGH or HI50

SOURCE subsystem

This subsystem allows to control the individual functions of M142 calibrator.

Keyword	Parameters
[SOURCE]	
: FUNCTION	
[: SHAPe] (?)	<CPD> { DC SINusoid PULPositive PULSymmetrical PULNegative RMPA RMPB TRIangle LIMSinusoid PWMPositive PWMSymmetrical PWMNegative SQUARE }
: VOLTage	
[: LEVEL]	
[: IMMEDIATE]	
[: AMPLitude] (?)	<DNPD>
: CURRent	
[: LEVEL]	
[: IMMEDIATE]	
[: AMPLitude] (?)	<DNPD>
: RESistance	
[: LEVEL]	
[: IMMEDIATE]	
[: AMPLitude] (?)	<DNPD>
: CAPacitance	
[: LEVEL]	
[: IMMEDIATE]	
[: AMPLitude] (?)	<DNPD>
: POWEr	
[: LEVEL]	
[: IMMEDIATE]	
[: AMPLitude] (?)	<DNPD>
: PHASe	
: UNITS (?)	<CPD> { DEG COS }
[: ADJust] (?)	<DNPD>
: VOLTage	
[: LEVEL]	
[: IMMEDIATE]	
[: AMPLitude] (?)	<DNPD>
: CURRent	
[: LEVEL]	

[: IMMEDIATE]	
[: AMPLITUDE] (?)	<DNPD>
: EARTH	
: VOLTAGE (?)	<CPD> { ON OFF 0 1 }
: CURRENT (?)	<CPD> { ON OFF 0 1 }
: AUXILIARY (?)	<CPD> { ON OFF 0 1 }
: ADAPTER (?)	
: FREQUENCY	
[: CW] (?)	<DNPD>
: DUTY (?)	<DNPD>
: VOLT (?)	<DNPD>
: ATTE (?)	<DNPD>
: TEMPERATURE	
: UNITS (?)	<CPD> { C CEL K }
: SCALE (?)	<CPD> { TS68 TS90 }
: THERMOCOUPLE	
[: LEVEL]	
[: IMMEDIATE]	
[: AMPLITUDE] (?)	<DNPD>
: RJUNCTION (?)	<DNPD>
: TYPE (?)	<CPD> { B E J K N R S T }
: PRT	
[: LEVEL]	
[: IMMEDIATE]	
[: AMPLITUDE] (?)	<DNPD>
: TYPE (?)	<CPD> { PT385 PT392 NI }
: RESISTANCE (?)	<DNPD>

[SOUR] :FUNC [:SHAP] (?) <CPD> { DC | SIN | PULP | PULS | PULN | RMPA | RMPB | TRI | LIMS | PWMP | PWMS | PWMN | SQU }

This command sets the shape of the output signal. At the same time, the respective function must be set. E.g. for :VOLT or :CURR function, FUNC DC, FUNC SIN, or other signal shape must be set. Some functions (:RES, :CAP) do not require any other settings.

- DC sets a DC output signal for voltage, current or power modes.
- SINusoid sets AC output signal for voltage, current or power modes.
- PULPositive sets AC squarewave signal for voltage or current modes. The amplitude and duty cycle can be set. The rectangles are positive, i.e. switching between 0 and +amplitude.
- PULSymmetrical sets AC squarewave signal for voltage or current modes. The amplitude and duty cycle can be set. The rectangles are symmetrical, i.e. switching between -amplitude and +amplitude.
- PULNegative sets AC squarewave signal for voltage or current modes. The amplitude and duty cycle can be set. The rectangles are negative, i.e. switching between -amplitude and 0.
- RMPA sets AC output signal - ramp shape - for voltage or current modes. The amplitude can be set. -The output switches between -amplitude a +amplitude.
- RMPB sets AC output signal - ramp shape - for voltage or current modes. The amplitude can be set. -The output switches between -amplitude a +amplitude.
- TRIangel sets AC output signal - triangular shape - for voltage or current modes. The amplitude can be set. -The output switches between -amplitude a +amplitude.
- LIMSinusoid sets AC output signal - sinus shape with limitation of amplitude- for voltage or current modes. The amplitude can be set. -The output switches between -amplitude a +amplitude.
- PWMPositive sets POS type output signal - digital pulse width modulation.
- PWMSymmetrical sets SYM type output signal - digital pulse width modulation.
- PWMNegative sets NEG type output signal - digital pulse width modulation.

- SQUare sets HSO type output signal - digital pulse output.

If query is sent, M142 returns a string containing { DC | SIN | PULP | PULS | PULN | RMPA | RMPB | TRI | LIMS | PWMP | PWMS | PWMN | SQU } depending on the current setting. If impedance or temperature sensor simulation is set, NONE is returned.

[SOUR] :VOLT [:LEVE] [:IMM] [:AMPL] (?) <DNPD>

This command activates the generation of DC or AC voltage (depending on the DC or SIN parameter of the FUNC command).

<DNPD>

Represents the value of DC or AC voltage expressed in Volts. Negative value is accepted for DC voltage. "Technical Data" chapter lists the acceptable ranges.

If query is sent, M142 returns the set value of current using standard exponential format. Example: 20.547mV is returned as -2.054700e-002. Positive numbers are not preceded with "+" sign.

[SOUR] :CURR [:LEVE] [:IMM] [:AMPL] (?) <DNPD>

This command activates the generation of DC or AC current (depending on the DC or SIN parameter of the FUNC command).

<DNPD>

Represents the value of DC or AC current expressed in Amperes. Negative value is accepted for DC current. "Technical Data" chapter lists the acceptable ranges.

If query is sent, M142 returns the set value of current using standard exponential format. Example: 20.547mA is returned as -2.054700e-002. Positive numbers are not preceded with "+" sign.

[SOUR] :RES [:LEVE] [:IMM] [:AMPL] (?) <DNPD>

This command activates the generation of a resistance.

<DNPD>

Represents the value of the resistance in Ohms. "Technical Data" chapter lists the acceptable ranges.

If query is sent, M142 returns the set value of resistance using standard exponential format. Example: 20.5Ω is returned as 2.050000e+001.

[SOUR] :CAP [:LEVE] [:IMM] [:AMPL] (?) <DNPD>

This command activates the generation of a capacitance.

<DNPD>

Represents the value of the capacitance in Ohms. "Technical Data" chapter lists the acceptable ranges.

If query is sent, M142 returns the set value of capacitance using standard exponential format. Example: 20.5nF is returned as 2.050000e-008.

[SOUR] :POWE :PHAS :UNIT (?) <CPD> { DEG | COS }

This command sets the method used to specify the phase shift between the output voltage and current.

- DEG activates a mode where all entries are done using the angle, °, in the range of 0.0 – 360.0°
- COS activates a mode where all entries are done using the power factor in the range of 1.000 to –1.000, LAG or LEAD (LAG = 0-180°, LEAD = 180-360°)

The unit of measurement remains valid even after the calibrator is switched off and back on.

If query is sent, M142 returns the set unit of measurement { DEG | COS }.

Example: PHAS :UNIT DEG <cr> - sets the angle as the unit of measurement
PHAS :UNIT ? <cr> - the calibrator returns DEG

[SOUR] :POWE :PHAS (?) <DNPD> [, { LEAD | LAG }]

This command sets the phase shift between the output voltage and current. At the same time, the power generation mode is set.

<DNPD>

Represents the phase shift between the output voltage and current in degrees (DEG setting), or specified as a value of the power factor (COS setting). “Technical Data” chapter lists the acceptable ranges.

,{LEAD|LAG}

This parameter is entered only when specifying the value of the power factor. If the value is omitted, LAG is used.

If query is sent, M142 returns the set value of the phase shift between the output voltage and current using standard exponential format. Example: 156.3 ° is returned as 1.563000e+002.

Example: POWE :PHAS 250.2 <cr> - activates the power generation mode and sets 250.2° phase shift between the output voltage and current
POWE :PHAS ? <cr> - the calibrator returns 2.502000e+002

Example: POWE :PHAS 0.554 ,LAG <cr> - activates the power generation mode and sets 0.554 LAG power factor
POWE :PHAS ? <cr> - the calibrator returns 5.540000e-001,LAG

[SOUR] :POWE :VOLT [:LEVE] [:IMM] [:AMPL] (?) <DNPD>

This command sets the amplitude of the voltage for power generation. At the same time, the power generation mode is set.

<DNPD>

Represents the voltage, expressed in Volts, used to generate the power. “Technical Data” chapter lists the acceptable ranges.

If query is sent, M142 returns the set value of the voltage using standard exponential format. Example: 100.3V is returned as 1.003000e+002.

[SOUR] :POWE :CURR [:LEVE] [:IMM] [:AMPL] (?) <DNPD>

This command sets the amplitude of the current for power generation. At the same time, the power generation mode is set.

<DNPD>

Represents the current, expressed in Amperes, used to generate the power. “Technical Data” chapter lists the acceptable ranges.

If query is sent, M142 returns the set value of the current using standard exponential format. Example: 1.3A is returned as 1.300000e+000.

[SOUR] :EART :VOLT (?) <CPD> { ON | OFF | 0 | 1 }

This command connects or disconnects the voltage Lo terminal to/from GND terminal.

- ON or 1 grounds the voltage output
- OFF or 0 ungrounds the voltage output

If query is sent, M142 returns ON when the output is grounded or OFF when ungrounded.

Example: EART : VOLT 1 <cr> - grounds the voltage output terminals
 EART : VOLT ? <cr> - the calibrator returns ON or OFF

[SOUR] :EART :CURR (?) <CPD> { ON | OFF | 0 | 1 }

This command connects or disconnects the current Lo terminal to/from GND terminal.

- ON or 1 grounds the current output
- OFF or 0 ungrounds the current output

If query is sent, M142 returns ON if the current terminals are grounded or OFF if ungrounded.

Example: EART : CURR 1 <cr> - grounds the current output terminals
 EART : CURR ? <cr> - the calibrator returns ON or OFF

[SOUR] :AUX (?) <CPD> { ON | OFF | 0 | 1 }

This command connects or disconnects the output signals to AUXILIARY connector.

- ON or 1 - output signals are connected to AUXILIARY connector, front panel terminals are disconnected.
- OFF or 0 - output signals are connected to front panel terminals, AUXILIARY connector is disconnected.

If query is sent, M142 returns ON when the signals are connected to AUXILIARY connector or OFF when the signals are connected front panel terminals.

Example: AUX 1 <cr> - output signals are connected to AUXILIARY connector
 AUX ? <cr> the calibrator returns ON or OFF

[SOUR] :AUX :ADAP (?)

This command can be used to find out what type of cable adapter is connected to AUXILIARY connector.

If query is sent, M142 returns the type of cable adapter connected to AUXILIARY connector { NONE | CA14001 | CA14041 | CA14040 | CA14060 | CA5 | CA6 | CA7 }.

Example: AUX :ADAP ? <cr> - the calibrator returns NONE, when no cable adapter is connected, or the type of cable adapter connected to AUXILIARY connector

[SOUR] :FREQ [:CW] (?) <DNPD>

This command sets the frequency being generated.

Examples:

AC voltage frequency :

FUNC :SIN ; :VOLT <DNPD>; :FREQ <DNPD> <cr>

AC current frequency :

FUNC :SIN ; :CURR <DNPD>; :FREQ <DNPD> <cr>

Digital frequency :

FUNC :SQU ; :FREQ <DNPD> <cr>

<DNPD>

Represents the frequency in Hz. . “Technical Data” chapter lists the acceptable ranges which depend on the selected function mode.

If query is sent, M142 returns the set value of the current using standard exponential format. Example: 20.5kHz is returned as 2.050000e+004.

[SOUR] :FREQ :DUTY (?) <DNPD>

This command sets the duty cycle of PULP, PULS, PULN, PWMP, PWMS, PWMN function modes.

Examples:

To set symmetrical squarewave voltage signal, 10V with defined duty cycle:

VOLT 10.0; FUNC :PULS ; **FREQ :DUTY** <DNPD> <cr>

To set digital frequency POS signal with defined duty cycle :

FUNC :PWMP ; **FREQ :DUTY** <DNPD> <cr>

<DNPD>

Represents the duty cycle in percent. 0 to 100% can be set.

If query is sent, M142 returns the set value of the duty cycle using standard exponential format. Example: 25% is returned as 2.50000e+001.

[SOUR] :FREQ :VOLT (?) <DNPD>

This command sets the amplitude of PWMP, PWMS, PWMN signals.

Examples:

To set the amplitude of PWMP digital frequency signal:

FUNC :PWMP ; **FREQ :VOLT** <DNPD> <cr>

<DNPD>

Represents the voltage in Volts. 0.000 to 10.000 V can be set.

If query is sent, M142 returns the set value of the amplitude using standard exponential format. Example: 2.05V is returned as 2.05000e+000.

[SOUR] :FREQ :ATTE (?) <DNPD>

This command sets the attenuation of digital SQU frequency signal.

Examples:

To set the attenuation of high frequency signal:

FUNC :SQU ; **FREQ :ATTE** <DNPD> <cr>

<DNPD>

Represents the attenuation in decibels. 0 to -30 dB can be set in 10 dB increments.

If query is sent, M142 returns the set value of the attenuation using standard exponential format. Example: -20 dB is returned as -2.00000e+001.

[SOUR] :TEMP :UNIT (?) <CPD> { C | CEL | K }

This command sets the unit of measurement of temperature.

- C or CEL sets „Centigrade“
- K sets „Kelvin“

The unit of measurement remains valid after the calibrator is switched off.

If query is sent, M142 returns the set unit of measurement { C | K }.

[SOUR] :TEMP :SCAL (?) <CPD> { TS68 | TS90 }

This command sets one of temperature scales. The setting influences the simulation of resistance temperature sensors and thermocouples.

- TS68 sets IPTS-68 temperature scale
- TS90 sets ITS-90 temperature scale

The temperature scale remains valid after the calibrator is switched off.

If query is sent, M142 returns the set temperature scale { TS68 | TS90 }.

[SOUR] :TEMP :THER [:LEVE] [:IMM] [:AMPL] (?) <DNPD>

This command activates the simulation of thermocouples (DC voltage generation).

<DNPD>

Represents the temperature expressed in the units set by the 'UNIT' command. "Technical Data" chapter lists the acceptable ranges.

If query is sent, M142 returns the set temperature using standard exponential format. Example: 20.5°C is returned as 2.050000e+001.

[SOUR] :TEMP :THER :RJUN (?) <DNPD>

This command sets the temperature of cold end of thermocouple.

<DNPD>

Represents the temperature expressed in the units set by the 'UNIT' command. "Technical Data" chapter lists the acceptable ranges.

Example: to set the temperature of cold end of thermocouple to 25°C:

```
:TEMP :THER :RJUN 25 <cr>
```

If query is sent, M142 returns the set temperature using standard exponential format. Example: 20.5°C is returned as 2.050000e+001.

[SOUR] :TEMP :THER :TYPE (?) <CPD> { B | E | J | K | N | R | S | T }

This command sets the type of thermocouple to be simulated.

Example: to activate the simulation of S type thermocouple at 350°C:

```
:TEMP :THER 350; :TEMP :THER :TYPE S <cr>
```

If query is sent, M142 returns the set type thermocouple { B | E | J | K | N | R | S | T }.

[SOUR] :TEMP :PRT [:LEVE] [:IMM] [:AMPL] (?) <DNPD>

This command activates the simulation of resistance temperature sensors (resistance generation).

<DNPD>

Represents the temperature expressed in the units set by the 'UNIT' command. "Technical Data" chapter lists the acceptable ranges.

If query is sent, M142 returns the set temperature using standard exponential format. Example: 20.5°C is returned as 2.050000e+001.

[SOUR] :TEMP :PRT :TYPE (?) <CPD> { PT385 | PT392 | NI }

This command sets the type of resistance temperature sensor to be simulated.

Example: to activate the simulation of platinum resistance temperature sensor at 350°C approximated using PT385 table (Europe):

```
:TEMP :PRT 350; :TEMP :PRT :TYPE PT385 <cr>
```

If query is sent, M142 returns the set type of approximation table { PT385 | PT392 | NI }.

[SOUR] :TEMP :PRT :NRESistance (?) <DNPD>

This command sets the nominal resistance of the resistance temperature sensor at 0°C. 10Ω to 2kΩ can be set.

<DNPD>

Represents the nominal resistance in Ohms.

If query is sent, M142 returns the set value of nominal resistance using standard exponential format. Example: 20.5Ω is returned as 2.050000e+001.

MEASure subsystem

This subsystem allows to control the internal multimeter of M142 calibrator. It sets the multimeter's functions and reads measured values.

Keyword**Parameters**

MEASure

?

: CONFigure

: VOLTage

: CURRent

: MVOLTage

: RESistance

: FREQuency

: TEMPerature

: RTD

: TYPE (?)

<CPD> { PT385 | PT392 }

: NRESistance (?)

<DNPD>

: THERmocouple

: TYPE (?)

<CPD> { B | E | J | K | N | R | S | T }

: RJUNction (?)

<DNPD>

MEAS ?

This command returns the measured value.

Example: 20.5Ω is returned as 2.050000e+001.

MEAS :CONF ?

M142 returns the set measurement mode { VOLT | CURR | MVOLT | RES | FREQ | TEMPerature:RTD | TEMPerature:THERmocouple | OFF }.

MEAS :CONF :VOLT

This command selects the function VOLT (range 0 .. 12V) of internal multimeter and switches it on.

Example: to set the multimeter to DC voltage 10V measurement mode:

```
MEAS :CONF :VOLT <cr>
```

MEAS :CONF :CURR

This command selects the function CURR (range 0 .. 25mA) of internal multimeter and switches it on.

Example: to set the multimeter to DC current 20mA measurement mode:

```
MEAS :CONF :CURR <cr>
```

MEAS :CONF :MVOLT

This command selects the function MVOLT (range 0 .. 2000mV) of internal multimeter and switches it on.

Example: to set the multimeter to DC voltage 2000mV measurement mode:

```
MEAS :CONF :MVOLT <cr>
```

MEAS :CONF :RES

This command selects the function RES (range 0 .. 2000Ω) of internal multimeter and switches it on.

Example: to set the multimeter to resistance measurement mode:

```
MEAS :CONF :RES <cr>
```

MEAS :CONF :FREQ

This command selects the function FREQ of internal multimeter and switches it on.

Example: to set the multimeter to frequency measurement mode:

```
MEAS :CONF :FREQ <cr>
```

MEAS :CONF :TEMP :RTD :TYPE (?) <CPD> { PT385 | PT392 }

This command selects the function RTD of internal multimeter, sets the type of resistance temperature sensor and switches the multimeter on.

Example: to set the multimeter to resistance temperature sensor type PT385 measurement mode:

```
MEAS :CONF :TEMP :RTD :TYPE PT385 <cr>
```

If query is sent, M142 returns the set type of approximation table { PT385 | PT392 }.

MEAS :CONF :TEMP :RTD :NRESistance (?) <DNPD>

This command selects the function RTD of internal multimeter, sets the nominal resistance of the resistance temperature sensor to 0°C and switches the multimeter on. 10Ω to 2kΩ can be set.

<DNPD>

Represents the nominal resistance in Ohms.

Example: to set the multimeter to resistance temperature sensor Pt100 measurement mode:

```
MEAS :CONF :TEMP :RTD :NRES 100 <cr>
```

If query is sent, M142 returns the set value of nominal resistance using standard exponential format. Example: 20.5Ω is returned as 2.050000e+001.

MEAS :CONF :TEMP :THER :TYPE (?) <CPD> { B | E | J | K | N | R | S | T }

This command selects the function TC of internal multimeter, sets the type of thermocouple and switches the multimeter on.

Example: to set the multimeter to thermocouple R measurement mode:

```
MEAS :CONF :TEMP :THER :TYPE R <cr>
```

If query is sent, M142 returns the set type of thermocouple { B | E | J | K | N | R | S | T }

MEAS :CONF :TEMP :THER :RJUNction (?) <DNPD>

This command selects the function TC of internal multimeter, sets the temperature of cold junction of selected thermocouple and switches the multimeter on.

<DNPD>

Represents the temperature expressed in the unit set by the 'UNIT' command. In "Technical Data" chapter there is list of acceptable ranges.

Example: to set the temperature of cold end of thermocouple to 25°C:

```
MEAS :CONF :TEMP :THER :RJUN 25 <cr>
```

If query is sent, M142 returns the set temperature using standard exponential format. Example: 20.5°C is returned as 2.050000e+001.

MEAS :CONF :OFF

This command switches the multimeter off.

TEST :RUN <DNPD>

This command starts selected procedure. Number 1 to 10 can be set.

<DNPD>

Represents number of procedure.

Example: to run test procedure 3 :

```
TEST :RUN 3 <cr>
```

TEST :RESU ?

M142 returns the result of selected procedure { PASS | FAIL | RUN }.

String „RUN“ is returned if selected procedure isn't finished.

I/D (instrument identification)***IDN?**

This command returns the identification of the manufacturer, model, serial number and firmware revision.

The reply is formatted as follows:

MEATEST, M-142, 412341, 4.6

Operation complete***OPC <cr>**

This command sets the OPC bit in the ESR (Event Status Register) when all pending operations are complete.

Operation complete?***OPC? <cr>**

This command returns “1” to the output queue after all pending operations are complete.

Operation complete?***OPC? <cr>**

This command returns “1” to the output queue after all pending operations are complete.

Wait-to-Continue command***WAI <cr>**

Prevents the instrument from executing any further commands or queries until all previous remote commands have been executed.

Reset***RST <cr>**

This command resets the calibrator to its initial status.

Test operation***TST? <cr>**

This command executes an internal self-test. Return the self-test result (“0” for pass or “1” for fail).

Status byte reading (IEEE488 only)***STB? <cr>**

This query returns the Status Byte Register including the MSS bit.

Service Request Enable setting (IEEE488 only)***SRE <value> <cr>**

This command sets condition of the Service Request Enable register. Since bit 6 is not used, the maximum entry is 191.

Service Request Enable reading (IEEE488 only)***SRE? <cr>**

This query returns the Service Request Enable Register.

Event Status Register reading (IEEE488 only)***ESR? <cr>**

This query returns the contents of the Event Status Register and clears the register.

Event Status Enable setting (IEEE488 only)***ESE <value> <cr>**

This command programs the Event Status Enable register bits. If one or more of the enabled events of the Event Status Enable register is set, the ESB of Status Byte Register is set too.

Event Status Enable reading (IEEE488 only)***ESE? <cr>**

This query returns the Event Status Enable register.

Clear status (IEEE488 only)***CLS <cr>**

This command clears the Event Status Register and the Status Byte Register except the MAV bit and output queue.

Remote control***REM <cr>**

This command activates the remote control. When the calibrator is controlled by GPIB bus, it goes to the remote control mode automatically. When remote control is active, the calibrator ignores all controls from the front panel, except LOCAL button.

Local control***LOC <cr>**

This command activates the local control (using front panel buttons). When the calibrator is controlled by GPIB bus, it goes to the local control mode automatically.

Local control lock

***LLO** <cr>

This command locks out the local control; the calibrator cannot be returned to local control by pressing LOCAL button. Return to local control can only be performed by a command sent through the bus, or by switching the calibrator off and on.

Local control unlock

***UNL** <cr>

This command cancels the „*LLO“ command. Unlocked calibrator can be returned to local control mode by pressing LOCAL button.

Standard Status Data Structures

All status registers are defined by the IEEE-488.2 standard. The programmer has access to Status Register, Enable Register and Output Queue in the M142 Calibrator.

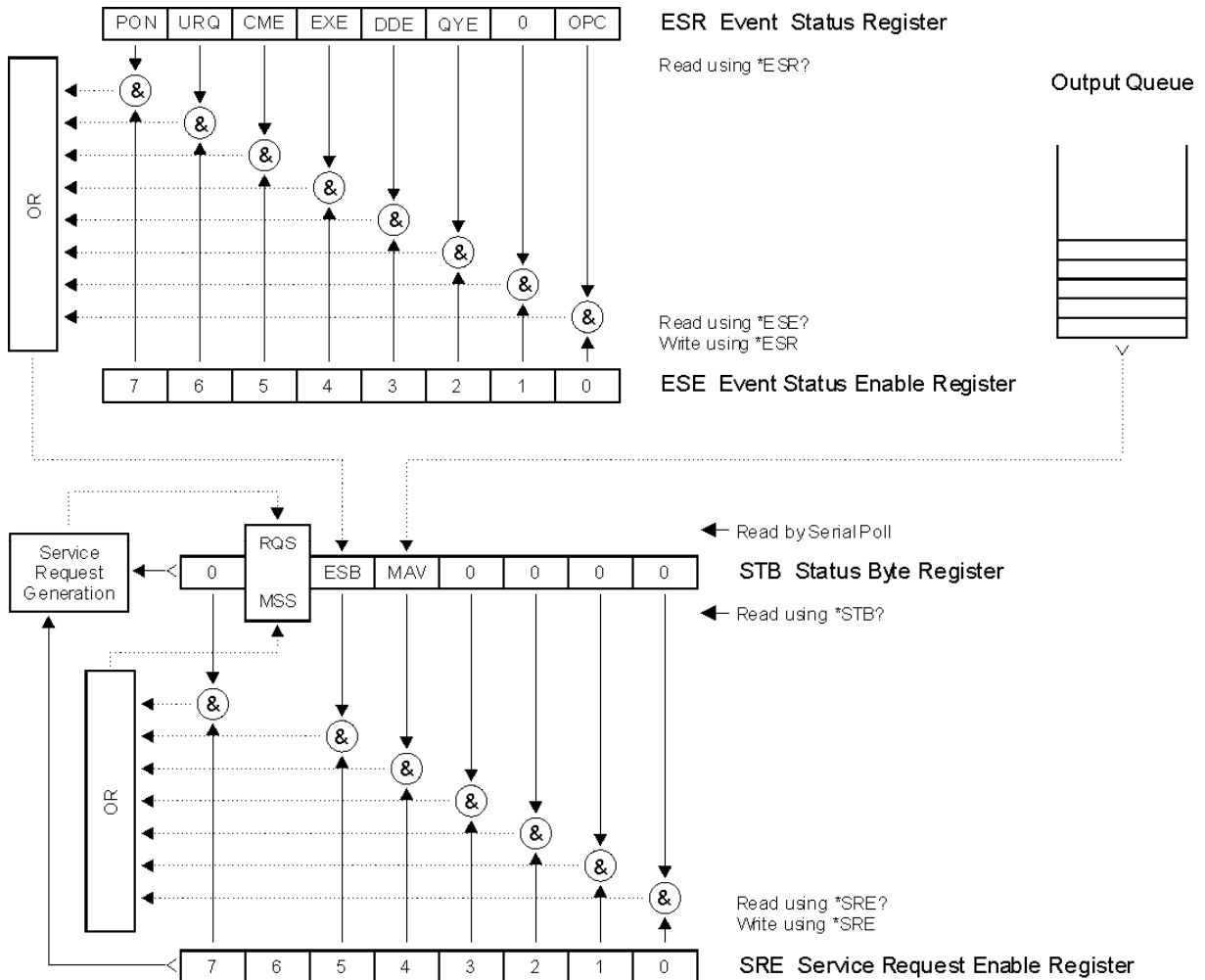

Status Register Overview

Status data structure of M142 Calibrator contains following registers:

- STB – Status Byte Register
- SRE – Service Request Enable Register
- ESR – Event Status Register
- ESE – Event Status Enable Register
- Output Queue

STB Status Byte Register

The summary messages from the Event Status Register and Output Queue are used to set or clear the appropriate bits (B4 and B5) of the Status Byte Register. These bits do not latch, and their states (0 or 1) are solely dependent on the summary messages (0 or 1). For example, if the Standard Event Register is read, its register will clear. As a result, its summary message will reset to 0, which in turn will clear the ESB bit in the Status Byte Register.

Bit configuration of Status Byte Register :

- RQS** Request Service, bit 6. The RQS bit is set to 1 whenever bits ESB or MAV change from 0 to 1 and are enabled (1) in the SRE. When RQS is 1, the M142 asserts the SRQ control line on the IEEE-488 interface. You can do a serial poll to read this bit to see if the M142 is the source of an SRQ.
- MSS** Master Summary Status, bit 6. The MSS bit is set to 1 whenever bits ESB or MAV are 1 and enabled (1) in the SRE. This bit can be read using the *STB? command in serial remote control in place of doing a serial poll.
- ESB** Event Summary Bit, bit 5. The ESB bit is set to 1 when one or more enabled ESR bits are set to 1. Conversely, the ESB bit is set to 0 when no enabled ESR bits are set to 1.
- MAV** Message Available, bit 4. The MAV bit is set to 1 whenever data is available in the M142 IEEE488 Output Queue. This message is used to synchronize information exchange with the controller. The controller can, for example, send a query command to the M142 and then wait for MAV to become TRUE. The IEC 625-1 bus is available for other use while an application program is waiting for a device to respond. If an application program begins a read operation of the Output Queue without first checking for MAV, all system bus activity is held up until the M142 responds.

SRE Service Request Enable Register

The Service Request Enable Register is an 8-bit register that enables corresponding summary messages in the Status Byte Register. Thus the application programmer can select reason for a device (M142) to issue a service request by altering the contents of the SRE. The Service Request Enable Register is read with the *SRE? common query. The response message to this query represents the sum of the binary-weighted values of the SRE. The value of unused bit 6 shall always be zero. The Service Request Enable Register is written with the *SRE common command followed by an integer value (0 – 191). Sending the *SRE common command followed by a zero clears the SRE. A cleared register does not allow status information to generate a rsv local message and thus, no service request are issued. The Service Request Enable Register is cleared upon power-on.

ESR Event Status Register

The Event Status Register is a two-byte register in which the higher eight bits are always 0, and the lower eight bits represent various conditions of the M142 calibrator. The ESR is cleared when the power is turned on, and every time it is read.

Bit configuration of Event Status Register :

- PON** Power On, bit 7. This event bit indicates that an off-to-on transition has occurred in the device's power supply.
- URQ** User Request, bit 6. This event bit indicates disconnecting or connecting of any cable adapter to the auxiliary connector on the front panel.
- CME** Command Error, bit 5. This event bit indicates that an incorrectly formed command or query has been detected by the M142.
- EXE** Execution Error, bit 4. This event bit indicates that the received command cannot be executed, owing to the device state or the command parameter being out of bounds.
- DDE** Device Dependent Error, bit 3. This event bit indicates that an error has occurred which is neither a Command Error, a Query Error, nor an Execution Error. A Device-specific Error is any executed device operation that did not properly complete due to some condition, such as overload.
- QYE** Query Error, bit 2. This event bit indicates that either:
 1. an attempt is being made to read data from the Output Queue when no output is either present or pending
 2. or data in the Output Queue has been lost
- OPC** Operation Complete, bit 0. This event bit is generated in response to the *OPC command. It indicates that the device has completed all selected pending operations.

ESE Event Status Enable Register

The Event Status Enable Register allows one or more events in the Event Status Register to be reflected in the ESB summary-message bit. This register is defined for 8 bits, each corresponding to the bits in the Event Status Register. The Event Status Enable Register is read with the common query *ESE?. Data is returned as a binary-weighted value. The Event Status Enable Register is written to by the common command, *ESE. Sending the *ESE common command followed by a zero clears the ESE. The Event Status Enable Register is cleared upon power-on.

Output Queue

The Output Queue stores response messages until they are read. The availability of output is summarized by the MAV (message available) summary message. The MAV summary message is used to synchronize information exchange with the controller. The Output Queue shall be a first in, first out (FIFO) Queue. The Output Queue is cleared upon power-on.

Examples of use

Calibration of measuring instruments

The calibrator can be used for direct calibration of various instruments which measure electrical values. Opt. 140-01 cable adapter is recommended. The cable adapter includes a temperature sensor which allows the measurement of external temperature. Measured value can be displayed by pressing INPUT button.

Multimeters

The calibrator can be used for calibration of digital and analogue multimeters (DCV, ACV, DCI, ACI, resistance, capacitance, temperature, frequency and duty cycle).

Voltage ranges

Thanks to low output impedance and high output current, the calibrator can be used for calibration of analogue voltmeters and millivoltmeters having low input impedance. Voltage output is connected to Hi/Lo terminals. The calibrator does not allow the four-wire connection of the instrument to be calibrated.

It is not recommended to connect non-standard load to the voltage output. The calibrator is designed to be used for calibration of voltmeters. Output terminals should be loaded with high and real impedance. Although the output is fitted with fast electronic and microprocessor protection, high capacitance or inductance loads can lead to oscillations of output amplifiers and result in damage.

The instrument to be calibrated can be connected either directly to the front panel terminals, or through Opt.140-01 cable adapter. If L terminal of the instrument to be calibrated is not grounded, then calibrator's Lo terminal should be grounded (GND U ON, see „Setup menu“ chapter).

Connection of a multimeter to be calibrated (voltage range) to calibrator's output terminals



Truncated waveform with defined distortion can be used for testing of multimeters

Connection of a multimeter to be calibrated (voltage range) to the terminals of 140-01 cable adapter

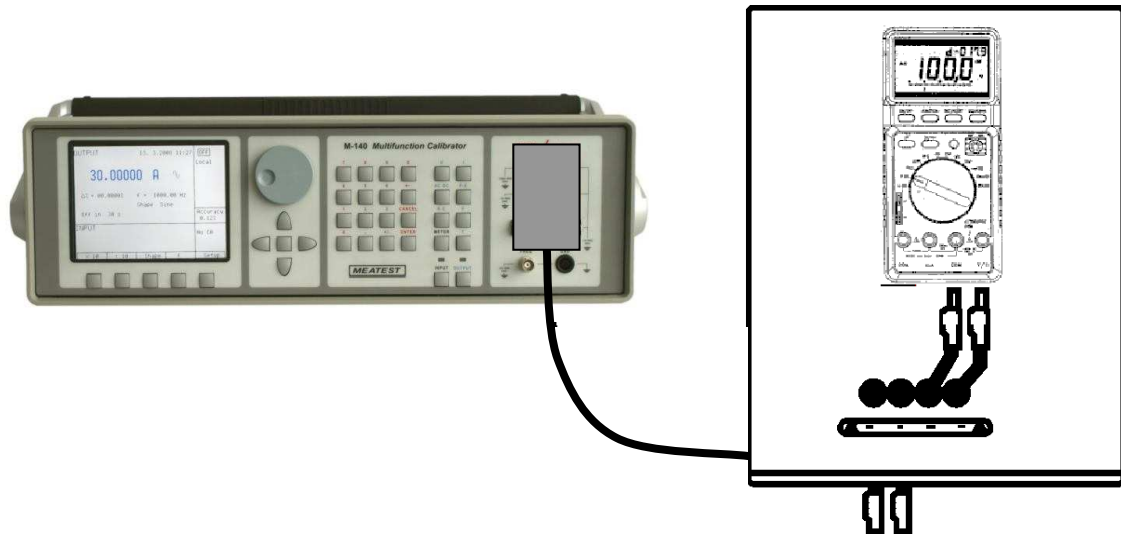

Current ranges

All DC and AC current ranges are connected to calibrator's +I/-I terminals.

When using the current output under heavy load (10 to 30 A), the runtime is limited to 0 to 60 s. The runtime depends on the set current and it is controlled by the microprocessor. The user cannot extend the runtime; if longer runtime is required, the output terminals must be unloaded, some time must elapse (for example 1 min.) and the load can then be connected again.

When feeding 2 to 30 A current to the output terminals, the output voltage must not exceed approx. 1.5 V_{rms} for currents to 20 A and 0.5 V_{rms} for current to 30 A. If the current induces higher voltage on the load, the calibrator disconnects the output terminals and displays an error message.

When ammeters are being calibrated using currents over 1 A, it is important to connect the terminals properly, paying attention both to the calibrator's output terminals and the instrument's input terminals. Excessive contact resistance can heat up the terminals and cause calibration errors. Excessive and unstable contact resistance has non-linear characteristic and can distort the output AC current.

It is not recommended to connect non-standard load to the current output. The calibrator is designed to be used for calibration of ammeters. Output terminals should be loaded with low and real impedance. Although the output is fitted with fast electronic and microprocessor protection, high capacitance or inductance can lead to oscillations of output amplifiers and result in damage.

The instrument to be calibrated can be connected either directly to the front panel terminals, or to Opt.140-01 cable adapter. If L terminal of the instrument to be calibrated is not grounded, then calibrator's -U (-I) terminal should be grounded (GND U ON, GND I ON, see „Setup menu“ chapter).

Connection of a multimeter to be calibrated (current range) to calibrator's output terminals

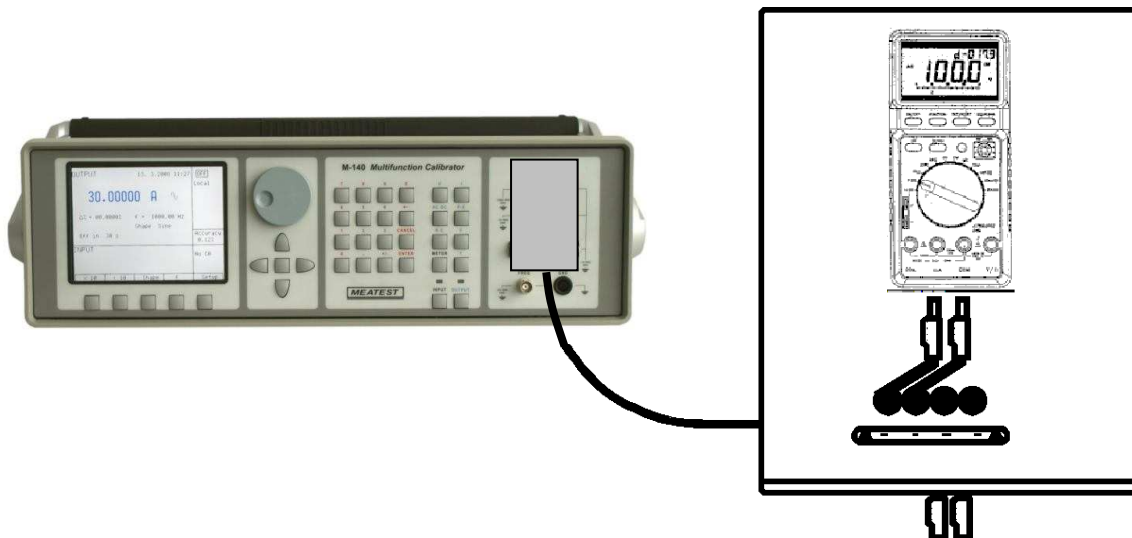

Optional current coil can extend the calibrator's current range to 1000 A. The coil can be used for calibration of both DC and AC ammeters. The clamps of the ammeter must be positioned in angle 90° to the coil. When using the current coil, no steel or other magnetic objects must be present in the vicinity (50 cm) of the current coil, as they would deform the magnetic field and cause big calibration error.

Connection of current coil:

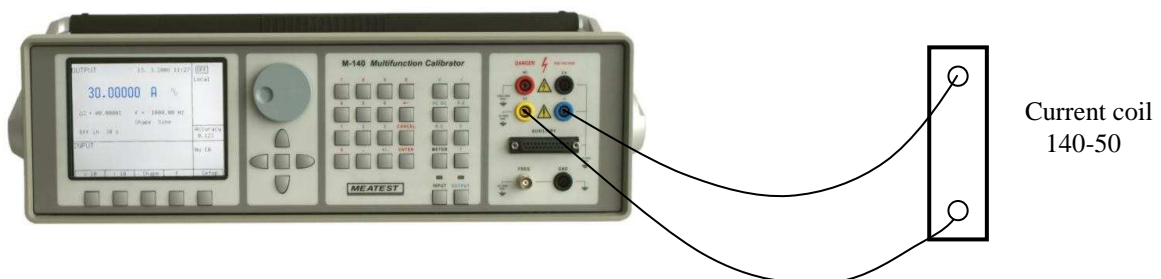

Powermeters

The calibrator can be used for calibration of DC and AC digital and analogue powermeters and energy meters.

The following limitations apply:

voltage	0.2 V to 240 V
current	2 mA to 20 A
frequency	DC, 40 Hz to 400 Hz
time	1.1 s to 1999 s
phase shift	-180 to +180°

The display can show active, reactive and apparent power and energy values. The phase shift between the output voltage and current can be set and displayed as well, either as the power factor (PF, $\cos \varphi$) or as the phase shift in degrees.

In the P-E mode, the permitted load of the voltage and current outputs is the same as in the voltage and current modes. If the output is overloaded, the calibrator disconnects the output terminals and displays an error message. For calibration of tong powermeters, current coil can be used. Power factor meters can be calibrated as well.

Basic connection of a powermeter to the calibrator

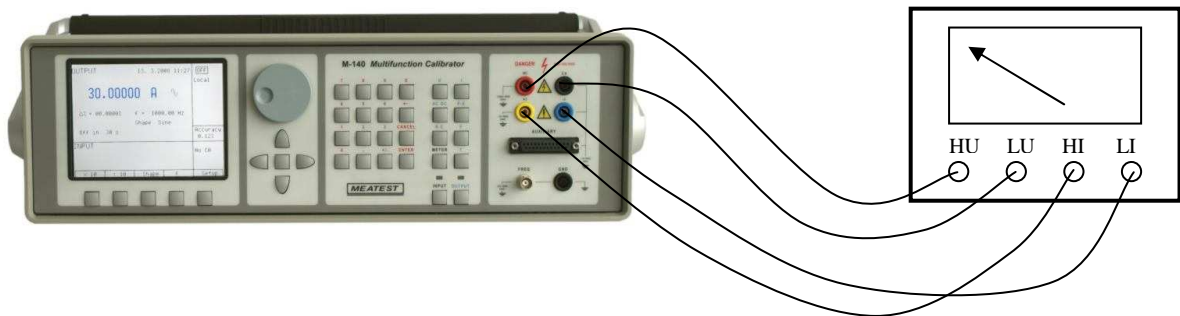

Possible methods of grounding of the measurement circuit

To prevent the creation of ground loops and to ensure the guaranteed precision of the calibrator, the powermeter to be calibrated as well as the calibrator must be properly grounded.

Depending on the nature of the measurement instrument to be calibrated, the following situations can occur:

<i>Device under test</i>	<i>GND U</i>	<i>GND I</i>
U input floating I input floating U and I inputs galvanically disconnected, not grounded	ON	ON
U input floating I input floating galvanically connected terminals L both U and I inputs, not grounded	ON (OFF)	OFF (ON)
voltage input grounded current input floating	OFF	ON
voltage input floating current input grounded	ON	OFF
both voltage and current inputs grounded	OFF	OFF

Tab. 18 Recommended way of signal terminal grounding

ATTENTION

The voltage between calibrator's –I and Lo outputs must not exceed 10 V.

Counters and oscilloscopes

The calibrator can be used for basic calibration of the frequency ranges of multimeters and simple counters. The calibrator provides the following functions:

- calibration of frequency functions up to 20 MHz using squarewave signal. The function is activated by pressing F direct mode button and selecting HF mode. Frequency can be set.
- check of input sensitivity from 1 mV to 10 V in the frequency range up to 100 kHz. The function is activated by pressing F direct mode button and selecting PWM mode. Frequency, amplitude and duty cycle can be set.
- calibration of time period using squarewave signal whose period can be set up to 10 s, with selectable duty cycle. The function is activated by pressing F direct mode button and selecting PWM mode. Frequency, amplitude and duty cycle can be set.

The instrument to be calibrated connects to FREQ connector using BNC/banana cable.

Connection of the frequency output



The calibrator can be used for basic calibration of oscilloscopes. The calibrator provides the following functions.

- check of time base up to 20 MHz using squarewave signal. The function is activated by pressing F direct mode button and selecting HF mode. Frequency can be set.
- check of vertical channel input sensitivity from 1 mV to 10 V in the frequency range up to 10 kHz. The function is activated by pressing F direct mode button and selecting PWM mode. Frequency, amplitude and duty cycle can be set.
- check of bandwidth using a signal up to 20 MHz with very steep rising edge (less than 5 ns). Calibration of time period using squarewave signal whose period can be set up to 10 s, with selectable duty cycle. The function is activated by pressing F direct mode button and selecting PWM mode. Frequency can be set. The delay of the signal displayed on the oscilloscope's screen is checked.

The oscilloscope to be calibrated connects to FREQ connector using a coaxial cable.

Thermometers

The calibrator can be used for calibration of transducers used in thermometers and heat meters, which use a thermocouple or Pt or Ni sensor. The block connected to the sensor is checked, as it is disconnected from the transducer and the calibrator's output is connected to the transducer's input instead. Simulation of thermal sensor is activated by pressing T direct mode button. Pt and Ni resistance temperature sensors as well as K, N, R, S, B, J, T, E thermocouples can be simulated.

The calibrator can be connected to transducer's input in one of the following ways:

- without the cable adapter, directly to Hi/Lo terminals. Temperature of cold junction must be compensated by manual setting of RJ value. The connection is similar to voltmeter connection.
- with cable adapter Option 140-01 to the terminals Hi/Lo. Automatic compensation of TC sensors cold junction can be used here. The cable adapter is equipped with build-in Pt1000 temperature, which measures ambient temperature. After build-in meter switching on (button INPUT ON) and with cable adapter 140-01 connected, automatic compensation of TC cold junction temperature is performed. When meter is

deactivated (INPUT OFF), cold junction temperature (RJ) can be set manually only. Connection of device under test is similar to the voltmeter connection.

- using 140-01 cable adapter and OUTPUT terminals. Temperature of cold junction must be compensated by manual setting of RJ value.

Measurement using the calibrator

Thanks to built-in multimeter, the calibrator can be used for basic calibration of some sources of electrical signals. The table lists the type of adapter which is necessary for a particular measurement.

DC voltage to 20 V	Opt. 40
DC voltage to 2 V	Opt. 80
DC current to 25 mA	Opt. 40
Resistance to 2 k Ω	Opt. 60
Impulse frequency to 15 kHz	Opt. 40
External TC temperature sensor	Opt. 80
External RTD temperature sensor	Opt. 60

Tab. 19 Application of cable adapters

Note: Cable adapters Option 40, 60, 70, 80 belong to basic delivery.

Voltage, current and frequency

10 V voltage range, 20 mA current range and frequency up to 15 kHz can be measured using Opt. 40 cable. The connection is simple. The cable is connected to calibrator's AUXILIARY connector, the other end has bananas which connect calibrator to the measured object. When making the connection, observe the polarity and connect the calibrator's L terminal to the L (common) or grounded terminal of the measurement instrument. To activate the measurement, select the respective function mode and press INPUT to measure the input value.

ATTENTION

The input terminals of the built-in multimeter are floating. Maximum voltage between the input terminals and the chassis is 15 Vpk. If this value is exceeded, the multimeter can be damaged.

If the measurement range is exceeded, the calibrator displays an error message; input terminals are disconnected only in the voltage and current measurement mode and remain connected in all other modes.

The multimeter allows the measurement of small DC voltages in the range of 0 to 2 V using Option 80 cable adapter. Connect inner two wires Hu and Lu to the object. To activate the measurement, select mVDC function mode using METER button in the function menu and press INPUT to measure the input value.

Measurement of resistance or temperature using resistance temperature sensors

Resistance can only be measured using four-wire connection using Opt. 60 cable adapter with four bananas, labeled Hi, Hu, Lu, Li. Their meaning is as follows:

- Hi current terminal H
- Hu voltage terminal H
- Lu voltage terminal L
- Li current terminal L

During the measurement of resistance or temperature using resistance temperature sensors, the rules applicable to the four-wire connection must be observed.

Connection of Pt100 sensor using Opt. 60 cable:

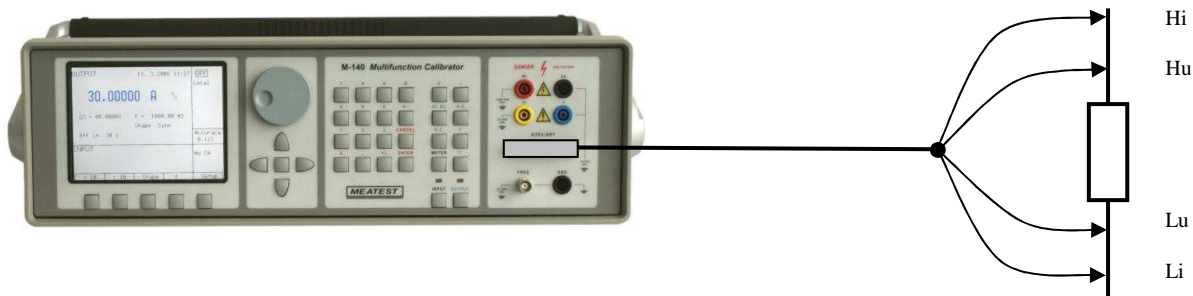

Measurement of temperature using thermocouples

The built-in multimeter allows the measurement of mV DC and temperature using external thermocouple. Option 80 cable adapter is required. Temperature of cold junction must be set manually. To activate the measurement, select T TC function mode using METER button in the function menu and press INPUT to measure the input value.

Connection of thermocouple to Option 80 cable adapter:



Testing of control unit, transducers and evaluation units

The calibrator can be used for calibration and testing of various instruments and regulators which must be fed by precise signal and whose response (electrical signal) is to be measured.

Two methods of connection can be used, each of them having different function and generation and measurement ranges.

Simultaneous mode can only be used if Opt 40, 60, 80 cable adapter is connected to AUXILIARY terminal. When no adapter is connected, simultaneous mode cannot be activated.

Option 40/60 cable adapter application

Cable adapter Option 40 cable supports simultaneous mode - measurement of voltage up to 12 V, current up to 25 mA and frequency up to 15 kHz. Option 60 cable adapter is designed for four-wire measurement of resistance or temperature using resistance temperature sensors.

Option 70 application

The adapter is aimed for four-wire sourcing of resistance values and for four-wire resistance temperature sensor simulation. Re-calibration of resistance function of the calibrator can be performed only with this adapter.

Resistance ranges are the same as two-wire resistance ranges with output on Hi – Lo terminals on front panel.

When adapter Option 70 is used, resistance output is only on output terminals on this adapter. Front panel Hi – Lo terminals are switched off.

When adapter Option 70 is used, set resistance value is connected to the adapter output terminals permanently. Status of button ON/OFF doesn't influence resistance connecting or disconnecting.

Option 80 application

The adapter is designed for mVDC and thermocouple temperature sensors measurement. Appropriate mode can be displayed by pushing METER button and selected from list of functions. When Option 80 adapter is connected to auxiliary connector only mVDC function with total range from 0 to 2 000 mV or temperature measurement is available. When connected external thermocouple to Option 80, temperature of the sensor is directly displayed. Type of thermocouple can be set in METER setup.

Table bellow shows measurement capability of different cable adapters connected to the auxiliary connector.

No.	function	140-41	140-40	140-60	140-70	140-80	140-90	140-01
1	V DC	Y	Y	N	N	N	N	N
2	mA DC	Y	Y	N	N	N	N	N
3	mV DC	Y	N	N	N	Y	N	N
4	R 4W	Y	N	Y	N	N	N	N
5	Freq	Y	Y	N	N	N	N	N
6	T TC	Y	N	N	N	Y	N	N
7	T RTD	Y	N	Y	N	N	Y	Y

Tab.20 overview of cable adapters

Note: Option 140-70 is applicable only for four-wire simulation of resistance
Option 140-41 belongs to M-140 model accessory however measuring section of the option (field INPUT) can be applied for M-142 model as well.

Option 90 application

Option 90 is Pt 1000 external temperature sensor suitable for automatic compensation of cold junction when simulating TC temperature sensors.

Examples of tests

Examples of applications

Sourcing/simulating	Measurement	Application
Pt 100 temperature sensor	10 V / 20 mA / f	Calibration of temperature evaluation units, setting of temperature regulators
TC temperature sensor	10 V / 20 mA / f	Calibration of temperature evaluation units, setting of temperature regulators
Frequency	10 V / 20 mA	Setting/calibration of energy meters
Resistance	10 V / 20 mA	Measurement of resistance bridges

Calibration of a single phase “electrical power/current loop” transducer

DUT – power transducer

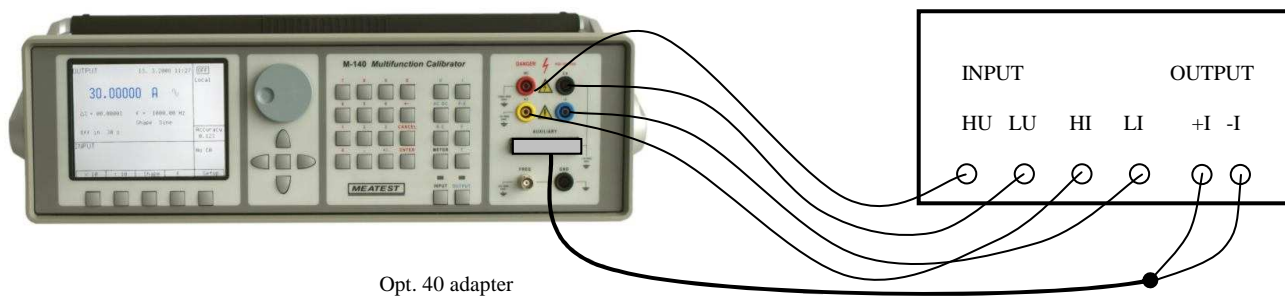

Opt. 40 adapter

Function setup: Calibrator P function (voltage, current, power factor, frequency)
 Multimeter DCI
 Adapter Opt. 40

Specification

Uncertainties include long-term stability, temperature coefficient, linearity, load and line regulation and the traceability of factory and National calibration standards. Specified accuracy is valid after one hour warm up in temperature range $23 \pm 2^\circ\text{C}$. Specified accuracy is one year accuracy.

Calibrator

Voltage

summary range DCV:	0 μV – 1000 V
summary range ACV:	0.1 mV – 1000 V
internal ranges:	20 mV, 200 mV, 2 V, 20 V, 240 V, 1000 V
voltage resolution:	61/2 digit
frequency resolution:	6 digit, minimum step 0.001Hz
frequency uncertainty:	0.005 %
frequency range:	20 Hz to 100 kHz bellow 20 V 20 Hz to 10 kHz bellow 200 V 20 Hz to 1000 Hz bellow 1000 V

DCV uncertainty

Range	% value + μV	Max. current [mA]	Protection against external voltage [Vpk]
0 μV – 20.00000 mV	0.005 + 6	1	60
20.00000 mV – 200.0000 mV	0.0015 + 8	5	60
0.200000 mV – 2.000000 V	0.0012 + 10	30	60
2.00000 V – 20.00000 V	0.0010 + 50	30	60
20.0000 V – 240.0000 V	0.0015 + 500	30	350
240.000 V – 1000.000 V	0.005 + 20 000	2	1450

*2 value of the range for uncertainty calculation is 200 V

ACV uncertainty

Range	% value + μV	Max. current [mA]	% value + % range	Max. current [mA]
	20 Hz - 10 kHz	20 Hz - 10 kHz	10 kHz - 50 kHz	10 kHz - 50 kHz
0.10000 mV – 20.00000 mV	0.2 + 30	0.5 * ³	0.20 + 0.10 + 20 μV	0.5 * ³
20.0000 mV – 200.0000 mV	0.1 + 80	4 * ³	0.15 + 0.05 + 20 μV	4 * ³
0.200000 mV – 2.000000 V	0.018 + 100	30	0.05 + 0.01	10
2.00000 V – 20.00000 V	0.018 + 1 000	30	0.05 + 0.03	10
20.0000 V – 240.0000 V * ²	0.018 + 10 000	30	--	--
240.000 V – 1000.000 V	0.03 + 200 000 * ¹	2	--	--

*¹ valid for $f < 1000$ Hz

*² value of the range for uncertainty calculation is 200 V, in the range 200 to 240 V is frequency limited to 1000 Hz.

*³ Output resistance < 0.1 Ohm. Minimum load resistance is 40 Ohm

Range	% value + % range	Max. current [mA]	Protection against external voltage [Vpk]
	50 kHz - 100 kHz	50 kHz - 100 kHz	
0.10000 mV – 20.00000 mV	1.0 + 0.10 + 20 μV	0.5 * ²	60
20.0000 mV – 200.0000 mV	0.3 + 0.05 + 20 μV	2 * ²	60
0.200000 mV – 2.000000 V	0.2 + 0.05	5	60
2.00000 V – 20.00000 V	0.2 + 0.05	5	60
20.0000 V – 240.0000 V * ²	--	--	350
240.000 V – 1000.000 V	--	--	1450

Auxiliary parameters

Range	20mV	200mV	2V	20V	200V	1000V
THD * ¹	0,05% + 200 μV	0,05% + 300 μV	0,05%	0,05%	0,05%	0,2%
output impedance	< 10 m Ω	< 10 m Ω	< 10 m Ω	< 10 m Ω	< 100 m Ω	< 100 m Ω
maximal capacitance load	800 pF	800 pF	30 nF	50 nF	10 nF	150 pF

*¹ parameter includes non-linear distortion and non-harmonic noise

*2 valid for frequencies to 10 kHz

Function Shape

voltage range: 1 mV to 200 V
 wave form: square, positive, negative, symmetrical, ramp A, ramp B, triangle
 truncated sin with THD 13,45 %
 peak value uncertainty: 0.3 % + 50 uV
 displayed values: peak, effective
 Minimum frequency for squarewave signals is 0.1 Hz, for all other wave shapes 20 Hz.

Current

summary range DCI: 0 µA - 30 A (with current coil 140-50 to 1000A)
 summary range ACI: 1 µA – 30 A (with current coil 140-50 to 1000 A)
 internal ranges: 200 µA, 2 mA, 20 mA, 200 mA, 2 A, 30 A
 resolution: 6 1/2 digit
 frequency resolution: 6 digit, minimum step 0.001Hz
 frequency uncertainty: 0.005 %
 frequency range: 20 Hz to 5 kHz bellow 200 mA
 20 Hz to 1000 Hz bellow 20 A
 40 Hz to 500 Hz in range 20 to 30 A

DCI uncertainty

Range	% value + µA	Min. compliance voltage [V]
0.0000 µA – 200.0000 µA	0.05 + 0.02	3
0.200000 mA – 2.000000 mA	0.02 + 0.1	3
2.000000 mA – 20.000000 mA	0.01 + 0.6	3
20.000000 mA – 200.000000 mA	0.01 + 6	3
0.200000 A – 2.000000 A	0.015 + 100	3
2.000000 A – 20.000000 A ^{*1}	0.02 + 2 000	1.5
20.000000 A – 30.000000 A ^{*1}	[0.02 + 0.003* (I-20)] + 2000 ^{*3}	0.5

ACI uncertainty

Range	% value + µA	Min. compliance voltage [Vrms]	% value + µA	Min. compliance voltage [Vrms]	% value + µA	Min. compliance voltage [Vrms]
	20 Hz - 1 kHz ^{*2}		1 kHz – 5 kHz		5 kHz – 10 kHz	
1.0000 µA – 200.0000 µA	0.15 + 0.02	3	0.30 + 0.22	3	--	--
0.200000 mA – 2.000000 mA	0.07 + 0.2	3	0.20 + 1	3	0.50 + 1.4	2
2.000000 mA – 20.000000 mA	0.05 + 1	3	0.20 + 10	3	0.50 + 14	2
20.000000 mA – 200.000000 mA	0.05 + 10	3	0.20 + 100	3	0.50 + 140	2
0.200000 A – 2.000000 A	0.05 + 100	3	--	--	--	--
2.000000 A – 20.000000 A ^{*1}	0.10 + 6000	1.5	--	--	--	--
20.000000 A – 30.000000 A ^{*1}	[0.1 + 0.003* (I-20)] + 6000 ^{*3}	0.5				

^{*1} Continuous current in range bellow 10 A. In range 10 to 30 A limited time to 60 s for current bellow 20 A and 30 s bellow 30 A.

^{*2} Frequency range for current 20 to 30 a is 40 Hz to 500 Hz

^{*3} I is set output current in [A]

When option 140-50 Current Coil is used, add uncertainty 0.3% of the set current to the value specified in above table. Output current is multiplied by factor 25 or 50 depending on applied coil range.

Auxiliary parameters

Range	200 uA	2 mA	20 mA	200 mA	2 A	20 A
maximal inductive load ^{*1}	1H	100 mH	100 mH	10 mH	1 mH	500 uH
THD ^{*2}	0,2%	0,2%	0,2%	0,2%	0,2%	0,3% ^{*3}

^{*1} DC and AC 50/60 Hz, voltage on the load < 2Vrms

^{*2} Parameter includes non-linear distortion and non-harmonic noise

^{*3} Distortion in range 20 to 30 A is max. 0.5%

Function Shape

current range: 100 uA to 2 A

wave form: square, positive, negative, symmetrical, ramp A, ramp B, triangle
truncated sin with THD 13,45 %
peak value uncertainty: 0.3 % + 500 nA
displayed values: peak, effective
Minimum frequency for squarewave signals is 0.1 Hz, for all others 20 Hz.

Resistance

summary range: 0 Ω to 1000 M Ω
resolution : 41/2 digit

Resistance uncertainty

Range	% of value * ¹ * ³	Resolution [Ω]	Applicable test current range	Max. voltage/current on lower range limit * ²	Max. voltage/current on higher range limit * ²
0 Ω - 10 Ω	0.03 + 5 m Ω	0.01	400 μ A - 100 mA	- / 100mA	1V / 100mA
10 Ω - 33 Ω	0.015 + 5 m Ω	0.01	400 μ A - 100 mA	1V / 100mA	3.3V / 100mA
33 Ω - 100 Ω	0.010 + 5 m Ω	0.01	400 μ A - 40 mA	3V / 100 mA	3.3V / 100mA
100 Ω - 330 Ω	0.010 + 5 m Ω	0.01	400 μ A - 40 mA	3V / 30 mA	10V / 30mA
330 Ω - 1 k Ω	0.010	0.1	400 μ A - 11 mA	3.3V / 10mA	10V / 10mA
1 k Ω - 3.3 k Ω	0.010	0.1	100 μ A - 6 mA	12V / 12mA	20V / 6mA
3.3 k Ω - 10 k Ω	0.010	1	20 μ A - 2 mA	12V / 3.5mA	20V / 2mA
10 k Ω - 33 k Ω	0.010	1	4 μ A - 600 μ A	12V / 1.2mA	20V / 600uA
33 k Ω - 100 k Ω	0.010	10	1 μ A - 200 μ A	12V / 360uA	20V / 200uA
100 k Ω - 330 k Ω	0.010	10	1 μ A - 60 μ A	12V / 120uA	20V / 60uA
330 k Ω - 1 M Ω	0.010	100	0.2 μ A - 20 μ A	12V / 36uA	20V / 20uA
1 M Ω - 3.3 M Ω	0.020	100	40 nA - 6 μ A	12V / 12uA	20V / 6uA
3.3 M Ω - 10M Ω	0.050	1.000	10 nA - 2 μ A	12V / 3.6uA	20V / 2uA
10 M Ω - 33 M Ω	0.1	1.000	10 nA - 600 nA	12V / 1.2uA	20V / 0.6uA
33 M Ω - 100M Ω	0.2	10.000	10 nA - 180 nA	12V / 0.36uA	20V / 0.18uA
100 M Ω - 1000 M Ω	0.5	10.000	4 nA - 20 nA	12V / 0.1uA	20V / 0.02uA

*¹ In range 0 Ω to 200 k Ω specification is valid for four-terminal connection using Option 70 Cable adapter. For two-terminal connection from front panel terminal add 20 mOhm.

*² Voltage is expressed in V pk-pk.

*³ In range 200 k Ω to 1000 M Ω specification is valid for two-terminal connection directly at front panel terminals Hi-Lo.

Capacitance

summary range: 0.7 nF to 100 μ F
resolution : 41/2 digit

Capacitance uncertainty

Range	% of value	Max. frequency [Hz]	Max. test voltage [V]
700 pF - 1 nF	0.5 + 15 pF	1000	2 - 5.5
1 nF - 3.3 nF	0.5 + 5 pF	1000	2 - 5.5
3.3 nF - 10 nF	0.5	1000	2 - 5.5
10 nF - 33 nF	0.5	1000	2 - 5.5
33 nF - 100 nF	0.5	500	2 - 5.5
100 nF - 330 nF	1	300	2 - 5.5
330 nF - 1 μ F	1	300	2 - 5.5
1 μ F - 3.3 μ F	1.5	300	2 - 5.5
3.3 μ F - 10 μ F	1.5	300	2 - 5.5
10 μ F - 100 μ F	2.0	300	2 - 5.5

AC and DC power/energy

summary voltage range: 0.2 V to 240 V
current capability of voltage output: depends on the voltage range
summary current range: 2 mA to 20 A
maximal voltage on current output: depends on the current range
electric power range: 0.0004 to 4.8 kVA
phase angle (PF range): -180° to +180° (-1 to +1 in PF)
phase angle (PF) resolution: 0.1° (0.001 in PF)
time period range: 1.1 s to 1999 s
time period accuracy: 0.01% + 0.1 s
time setting resolution: 0.1s
frequency range: DC, 40 Hz to 400 Hz
frequency resolution: 6 digit, minimum step 0.001Hz

DCV uncertainty

See table of DCV uncertainty.

DCI uncertainty

Range	% value + μA	Max. compliance voltage [V]
2.00000 mA – 20.00000 mA	0.05 + 2	3
20.0000 mA – 200.0000 mA	0.05 + 10	3
0.200000 A – 2.000000 A	0.05 + 100	3
2.00000 A – 20.00000 A ^{*1}	0.05 + 2000	1.5

^{*1} Continuous current in range below 10 A. In range 10 to 20 A limited time to 30 s.

DC POWER uncertainty

Uncertainty of DC power can be calculated from the following formula:

$$dP = \sqrt{(dU^2 + dI^2 + 0.01^2)} \quad [\%]$$

where dP is uncertainty of output power [%]
 dU is uncertainty of set voltage [%]
 dI is uncertainty of set current [%]

DC ENERGY uncertainty

Depends on voltage, current, time values. The best uncertainty is 0.016 %.

ACV uncertainty

See table of ACV uncertainty.

ACI uncertainty

Range	% value + μA	Max. compliance voltage [V]
2.00000 mA – 20.00000 mA	0.05 + 2	3
20.0000 mA – 200.0000 mA	0.05 + 10	3
0.200000 A – 2.000000 A	0.05 + 100	3
2.00000 A – 20.00000 A ^{*1}	0.05 + 2000	1.5

^{*1} Continuous current in range below 10 A. In range 10 to 20 A limited time to 30 s.

PHASE uncertainty

Frequency range [Hz]	Phase accuracy $d\phi$ [°]
40.000 – 200.000	0.15
200.001 – 400.000	0.25

AC POWER uncertainty

Uncertainty of AC power can be calculated from the following formula:

for active power $dP = \sqrt{(dU^2 + dI^2 + dPF^2 + 0.03^2)} \quad [\%]$
 for reactive power $dP = \sqrt{(dU^2 + dI^2 + dPF^{*2} + 0.03^2)} \quad [\%]$
 for apparent power $dP = \sqrt{(dU^2 + dI^2 + 0.03^2)} \quad [\%]$

where dP is uncertainty of power [%]
 dU is uncertainty of set voltage [%]
 dI is uncertainty of set current [%]
 dPF is uncertainty of power factor ($\cos\phi$) [%]

For calculation of dPF is valid following formula:

$$dPF = (1 - \cos(\phi + d\phi) / \cos\phi) * 100 \quad [\%]$$

where ϕ is set phase shift between voltage and current outputs
 $d\phi$ is uncertainty of set phase shift in table above

dPF^* is uncertainty of $\sin\phi$ [%]

For dPF* is valid following formula:

$$dPF^* = (1 - \sin(\varphi+d\varphi)/\sin \varphi) * 100 \quad [\%]$$

Example:

Set parameters: $U = 100 \text{ V}$, $I = 10 \text{ A}$, $\cos \varphi = 0.5$, $f = 50 \text{ Hz}$, displayed value of active power in W
 Output voltage uncertainty: $dU = 0.025 \% \text{ value} + 0.010 \% \text{ range} = 0.045 \%$
 Output current uncertainty: $dI = 0.05 \% \text{ value} + 0.01 \% \text{ range} = 0.06 \%$
 Uncertainty due the set phase shift: PF 0.5 corresponds phase shift 60°
 $dPF = (1 - \cos(60+0.15)/\cos 60) * 100 = (1 - 0.4977/0.5) * 100 = 0.45 \%$
 Output power uncertainty: $dP = \sqrt{(0.045^2 + 0.06^2 + 0.45^2 + 0.03^2)} = 0.46 \%$

POWER FACTOR (PF)

range: -1.0 to +1.0

PF uncertainty can be calculated for any set value of output voltage, current and PF from following formula:

$$dPF = (1 - \cos(\varphi+d\varphi)/\cos \varphi) * 100 \quad [\%]$$

where φ is set phase shift between voltage and current
 $d\varphi$ is uncertainty of set phase shift form the above table

AC ENERGY uncertainty

It depends on set value of voltage, current, time and PF. The best uncertainty is 0.07% for apparent energy.

Frequency

summary range: 0.1 Hz to 20 MHz
 frequency uncertainty: 0.005 %
 frequency resolution: 6 digit, minimum step 0.001Hz
 output: BNC connector located on the front panel
 modes: - PWM square wave output with calibrated duty cycle ratio, frequency and amplitude
 - HF square wave output with calibrated frequency and amplitude

Mode PWM

frequency range: 0.1 Hz to 100 kHz
 voltage range: 1 mV to 10 V
 duty cycle ratio range: 0.01 to 0.99
 wave form: square, symmetrical– positive – negative
 duty cycle ratio uncertainty: 0.05 %
 signal noise (20 Hz – 1 MHz): < 2 mV from 0.1Hz to 10 kHz
 < 10 mV from 10kHz to 100 kHz

Amplitude uncertainty (average top/bottom square signal level)

range	% value + V	% value + mV
	0.1 Hz to 10 kHz	10kHz to 100 kHz
1.00000 mV – 20.00000 mV	0.2 + 0.02 mV	0.2 + 0.1 mV
20.0001 mV – 200.0000 mV	0.1 + 0.02 mV	0.1 + 0.1 mV
0.200001 mV – 2.000000 V	0.1 + 0.02 mV	0.1 + 0.1 mV
2.00001 V – 10.00000 V	0.1 + 0.02 mV	0.1 + 0.1 mV

Mode HF

frequency range: 0.1 Hz to 20 MHz
 output impedance: 50 Ω
 wave form: square symmetrical, duty cycle ratio 1:1
 amplitude: 4 V_{pk-pk}
 output amplitude range: 0, -10, -20, -30 dB +/- 1 dB
 amplitude uncertainty: 10 %
 rise/fall time: < 3 ns

Temperature sensors simulation

temperature scale: ITS 90, PTS 68
 types of sensors: RTD, TC

A. RTD (resistance) sensors

types: Pt 1.385, Pt 1.392, Ni
 range of R0 setting: 20 Ω to 2 k Ω
 temperature range: -200 to +850 °C
 temperature uncertainty: 0.04 °C to 0.5 °C (see table bellow)
 resolution: 0.1 °

Ranges and uncertainties of RTD sensor simulation

type	range -200 – 250 °C	range 250 – 850 °C
Pt100	0.1 °C	0.3 °C
Pt200	0.1 °C	0.2 °C
Pt1000	0.2 °C	0.4 °C
Ni100	0.07 °C *1	- -

*1 Valid in range -60 to +180 °C.

Uncertainties in the table are maximal uncertainties of RTD sensor simulation. Actual uncertainty for each set value of simulated temperature is determined by uncertainty of relevant resistance. Actual temperature uncertainty is displayed on the calibrator display. Actual uncertainties are always lower than those in above table.

B. TC sensors:

types: K, N, R, S, B, J, T, E
 temperature range: -250 to +1820 °C according to the type
 temperature uncertainty: 0.4 to 4.3 °C (see the table bellow)
 resolution: 0.1 °

Ranges and uncertainties of TC sensor simulation

R	range [°C]	-50 - 0	0 - 400	400 – 1000	1000 – 1767
	uncertainty [°C]	1.8 - 1.4	1.4 - 0.7	0.7 - 0.6	0.6 - 0.5
S	range [°C]	-50 - 0	0 - 250	250 – 1400	1400 – 1767
	uncertainty [°C]	1.6 – 1.3	1.3 - 0.8	0.8 - 0.6	0.7 - 0.6
B	range [°C]	400 – 800	800 - 1000	1000 – 1500	1500 – 1820
	uncertainty [°C]	1.7 - 0.9	0.9 - 0.8	0.8 - 0.7	0.7 - 0.6
J	range [°C]	-210 - -100	-100 - 150	150 – 700	700 – 1200
	uncertainty [°C]	0.3 - 0.2	0.2 - 0.1	0.2 - 0.1	0.2
T	range [°C]	-200 - -100	-100 - 0	0 – 100	100 – 400
	uncertainty [°C]	0.4 - 0.3	0.2	0.2	0.1
E	range [°C]	-250 - -100	-100 - 280	280 – 600	600 – 1000
	uncertainty [°C]	0.7 - 0.2	0.2 - 0.1	0.1	0.1
K	range [°C]	-200 - -100	-100 - 480	480 – 1000	1000 – 1372
	uncertainty [°C]	0.5 - 0.2	0.2	0.3 - 0.2	0.3
N	range [°C]	-200 - -100	-100 - 0	0 – 580	580 – 1300
	uncertainty [°C]	0.7 - 0.3	0.3	0.2	0.2

Uncertainties in the table show range of the uncertainties of TC sensor simulation in specified range. Actual uncertainty for each set value of simulated temperature is determined by uncertainty of relevant DC voltage. Actual temperature uncertainty is displayed on the calibrator display.

Multimeter

Functions: DC voltage
DC current
resistance,
temperature

Ranges and uncertainties

function	total range	uncertainty (%)	resolution / range
DC voltage - DCV ^{*1}	0 to +/-20.0000 V	0.01 % + 500 μ V	100 μ V / 10V
DC voltage - mVDC ^{*1}	0 to +/-2.00000 V	0.02 % + 7 μ V	20mV / 100nV, 200mV / 1 μ V, 2V / 10 μ V
DC current ^{*1}	0 to +/-25.0000 mA	0.015 % + 300 nA	100 nA/20mA
Frequency	1.000 Hz to 15 000.00kHz	0.005	10 μ Hz – 0.1 Hz
Resistance ^{*2}	0.000 to 2 500.00 Ω	0.02% + 10 m Ω	20 Ω / 1m Ω , 200 Ω / 1m Ω , 2k Ω / 10m Ω
Temperature - PT sensor	-200.000 to +850.000 $^{\circ}$ C ^{*3}	0.1 $^{\circ}$ C	0.1 $^{\circ}$ C
Temperature – TC sensor	-250.00 to +1820.00 $^{\circ}$ C ^{*4}	see Table	0.01 $^{\circ}$ C

^{*1} Uncertainties are valid after performing ZERO correction in set mode

^{*2} Measuring current 1 mA

^{*3} For Pt 1000 sensor maximum temperature is 350 $^{\circ}$ C. Maximum measured resistance is 2 k Ω .

^{*4} Maximum allowed analogue input DC voltage is 2 V.

Ranges and uncertainties of temperature measuring with TC sensor

R	range [$^{\circ}$ C]	-50 - 0	0 – 400	400 – 1000	1000 – 1770
	uncertainty [$^{\circ}$ C]	2.5	1.5	1.0	1.2
S	range [$^{\circ}$ C]	-50 - 0	0 – 250	250 – 1400	1400 – 1770
	uncertainty [$^{\circ}$ C]	2.0	1.6	1.1	1.3
B	range [$^{\circ}$ C]	400 - 800	800 – 1000	1000 – 1500	1500 – 1820
	uncertainty [$^{\circ}$ C]	2.0	1.3	1.2	1.1
J	range [$^{\circ}$ C]	-210 - -100	-100 – 150	150 – 700	700 – 1200
	uncertainty [$^{\circ}$ C]	0.7	0.4	0.4	0.6
T	range [$^{\circ}$ C]	-200 - -100	-100 - 0	0 – 100	100 – 400
	uncertainty [$^{\circ}$ C]	0.8	0.5	0.4	0.4
E	range [$^{\circ}$ C]	-250 - -100	-100 - 280	280 – 600	600 – 1000
	uncertainty [$^{\circ}$ C]	1.1	0.4	0.4	0.5
K	range [$^{\circ}$ C]	-200 - -100	-100 - 480	480 – 1000	1000 – 1372
	uncertainty [$^{\circ}$ C]	0.8	0.4	0.6	0.8
N	range [$^{\circ}$ C]	-200 - -100	-100 – 0	0 – 580	580 – 1300
	uncertainty [$^{\circ}$ C]	0.9	0.5	0.5	0.8

Sorting function

Output GO/NG:

1 x make, 1 x break contacts, 50Vpp / 100mA

Triggering :

external, internal, manual

General data

Warm up time:	60 minutes
Specification interval:	1 year
Specification confidence level:	99 %
Range of working temperatures:	23 ± 10 °C, relative humidity < 75%
Temperature coefficient	Temperature coefficient for temperature outside of Tcal ±2 °C between +13 °C to +33 °C is 0.1 x /°C
Reference temperature:	23 ± 2 °C
Relative humidity:	< 70 % to 28 °C
Storage temperature:	- 10 to +55 °C
Altitude:	3 000 m operating 12 000 m storage
Electrostatic Discharge:	This instrument meets class I for ESD requirements per EN 61326
Dimension:	450 x 480 x 150 mm
Netto weight	23 kg
Power line:	115 - 220/230 V – 50/60 Hz
Power consumption:	45 VA without load, max. 400 VA with full load
Safety class:	I according IEC 61010 ed 2
Used external fuses:	F4L250V AC line input
Used internal fuses:	F1.6L250V 3 pcs F200mL250V 2 pcs F2.5L250V 2 pcs

Accessories**Basic accessories (included in delivery)**

• Power line cord	1 pc
• User's manual	1 pc
• Test report	1 pc
• Spare fuse	2 pc
• Test cable 1000V/30A, 1m	2 pc
• Option 40 Input cable adapter D-SUB25/ 2xbannana for VDC/mADC measurement	1 pc
• Option 60 Input cable adapter D-SUB25/ 4xbannana for 4W resistance / RTD temperature measurement	1 pc
• Option 70 Output cable adapter D-SUB25/ 4xbannana, 4W resistance source	1 pc
• Option 80 Input cable adapter D-SUB25/ 2xbannana for mVDC/TC temperature measurement	1 pc
• Cable RS232	1 pc

Options (extra ordered)

• 140-50	Current coil 50 turn
• 140-01	Cable adapter for calibration of multimeters with built-in temperature sensor.
• Option 10	Test lead 30A/1000V (black)
• Option 11	Test lead 30A/1000V (red)
• Option 20	Coaxial test lead BNC/BNC
• Option 30	Coaxial test lead BNC/ bannana
• Option 40	Input cable adapter D-SUB25/ 2xbannana for VDC/mADC measurement
• Option 60	Input cable adapter D-SUB25/ 4xbannana for 4W resistance / RTD temperature measurement
• Option 70	Output cable adapter D-SUB25/ 4xbannana, 4W resistance source
• Option 80	Input cable adapter D-SUB25/ 2xbannana for mVDC/TC temperature measurement
• Option 90	PT100 external temperature sensor
• Option 100	Adapter for 3/4" output terminals spacing
• Option 142-02	Test lead/test adapter set (Opt. 10, 11, 20, 30, 90, 140-01)
• Cable GPIB	IEEE488/IEEE488, 2m
• Cable RS232	Cable RS-232 for connecting to PC
• WinQbase	SW for calibration of instrument
• Caliber	Program module for multimeters

Manufacturer and service

MEATEST, s.r.o
Zelezna 3, 619 00 Brno
Czech Republic

tel: +420 – 543 250 886
fax: +420 – 543 250 890
meatest@meatest.cz
www.meatest.com

Operation Manual Supplement

Manual Title: M142
Issue date: 1/2014
Supplement issue: 003

This supplement contains information necessary to ensure the accuracy of the above manual.

Change 1

On page 115 the original text under the table “Resistance uncertainty” has been replaced with the following:

**1 Specification is valid for four-terminal connection using Option 70 Cable adapter. For two-terminal connection from front panel terminal add 20 mOhm.*

Change 2

On page 115 the text under the table “Resistance uncertainty” has been added:

**3 In range 200 kΩ to 1000 MΩ specification is valid for two-terminal connection directly to front panel terminals Hi-Lo.*

Change 3

On page 58 added explanation of standard ohmmeter connection during calibration procedure

Calibration in resistance range of calibration points from 0 Ω to 100 kΩ must be done using Option 70 cable adapter (four-terminal connection). Four-wire output resistance is defined at the test leads of the cable adapter.

Calibration in resistance range of calibration points from 100 kΩ to 1 GΩ must be done without Option 70 cable adapter application (two-terminal connection). Use front panel terminals Hi-Lo for connection of standard ohmmeter.

On page 58 added calibration point 190 MΩ to the Table 12 “Resistance”.